

## Montageanleitung Mounting instruction

für Hochschwenkbeschlag im Oberschrank mit Alu-Profil  
und 2 Gasdruckfedern

for swing-up fitting with Alu-Profile in the wall unit and 2 gas springs

Art.-Nr. 001348 ....., Art.-Nr.001349 ....., Art.-Nr.001352 .....

Art.-Nr.222859 ....., Art.-Nr.231127 .....

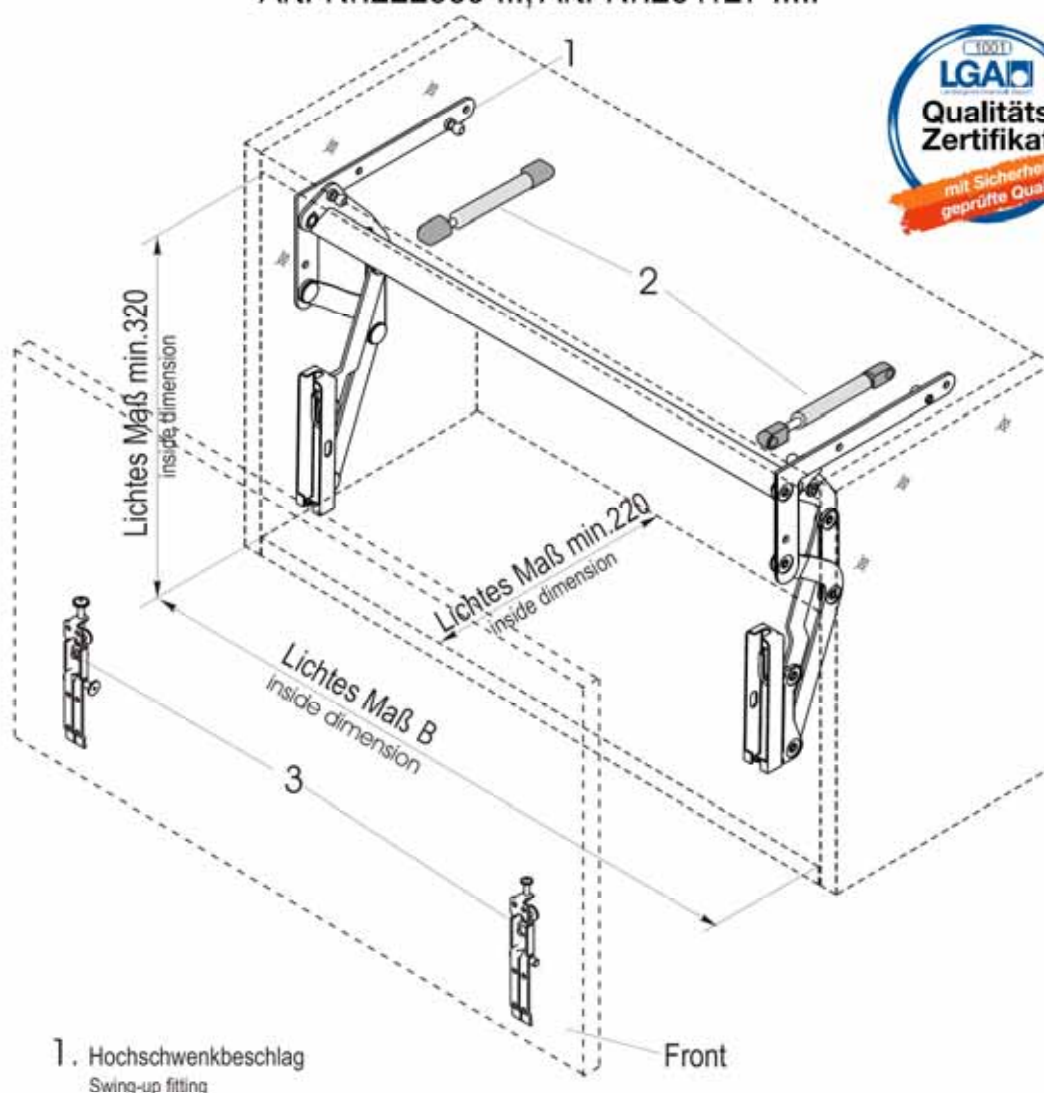

1. Hochschwenkbeschlag  
Swing-up fitting

2. Gasfeder  
gas spring

3. Montageplatten  
mounting brackets

Art.-Nr. Kesseböhmer:	Maß "B" dimension "B"	maximales Frontgewicht max. frontweight
001348 .....	max. 870 mm	5,0 kg
001349 .....	max. 1170 mm	7,0 kg
001352 .....	max. 1470 mm	8,5 kg
222859 .....	max. 670 mm	5,0 kg
231127 .....	max. 870 mm	5,0 kg

# KESSEBÖHMER

**A.** Profil zuschneiden  
Cut up the profile

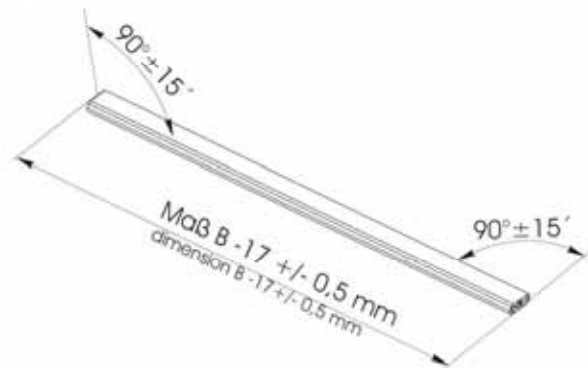

**B.** Hochschwenkbeschlag montieren  
Mount the swing-up fitting

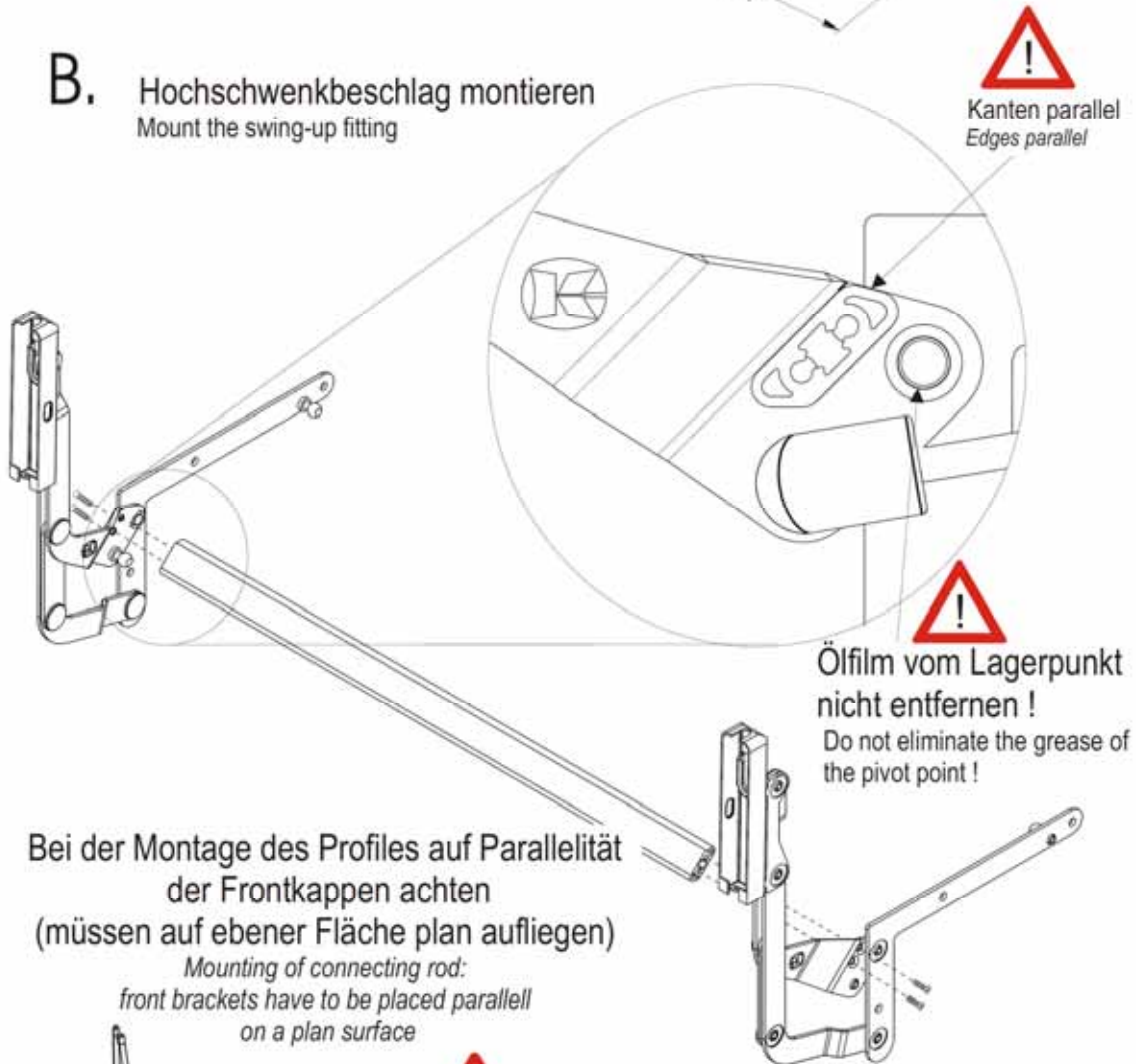

Bei der Montage des Profiles auf Parallelität der Frontkappen achten  
(müssen auf ebener Fläche plan aufliegen)

*Mounting of connecting rod:  
front brackets have to be placed parallel  
on a plan surface*



Blechschaube  
DIN 7982  
  
4,2x16-c 4x

**C.** Hochschwenkbeschlag einschrauben  
Screw the swing-up fitting

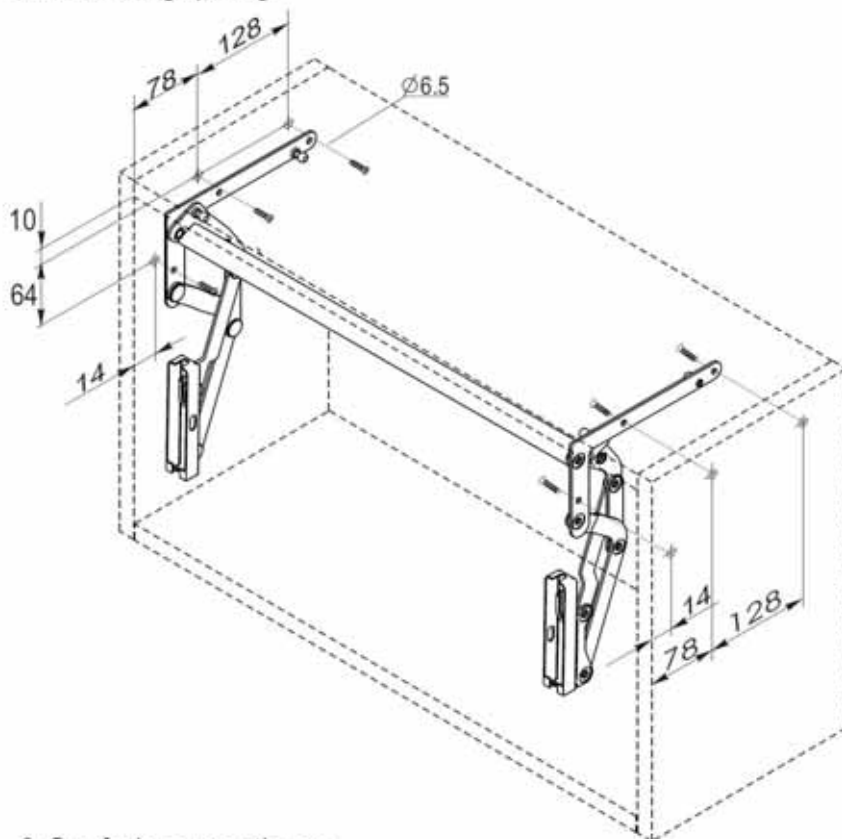

**D.** 2 Gasfedern montieren  
mount the gas springs

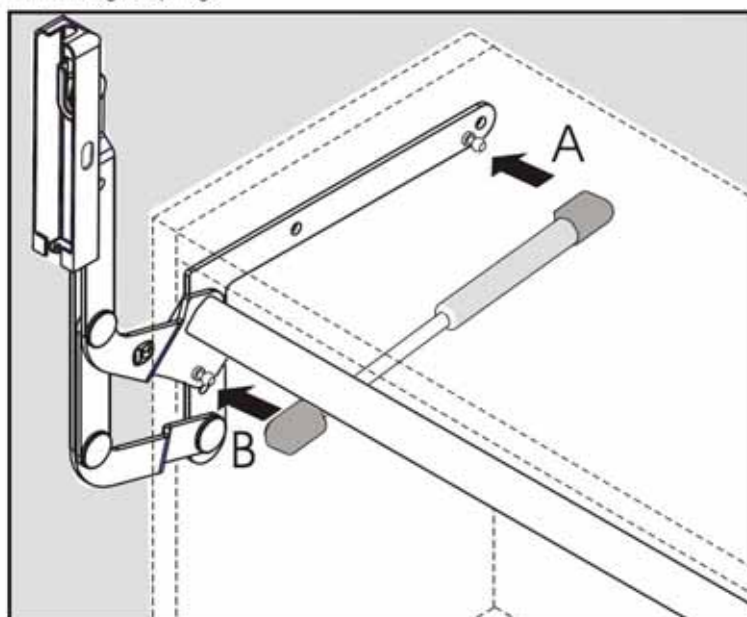

## E. Montageplatten an der Front verschrauben Screw the mounting brackets to the front



## F. Front einhängen und montieren Front justieren *Front fixing and mounting front adjusting*

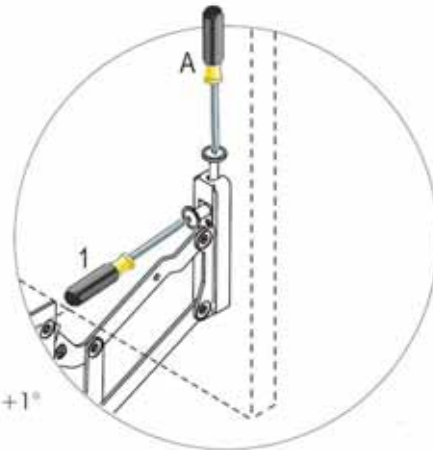
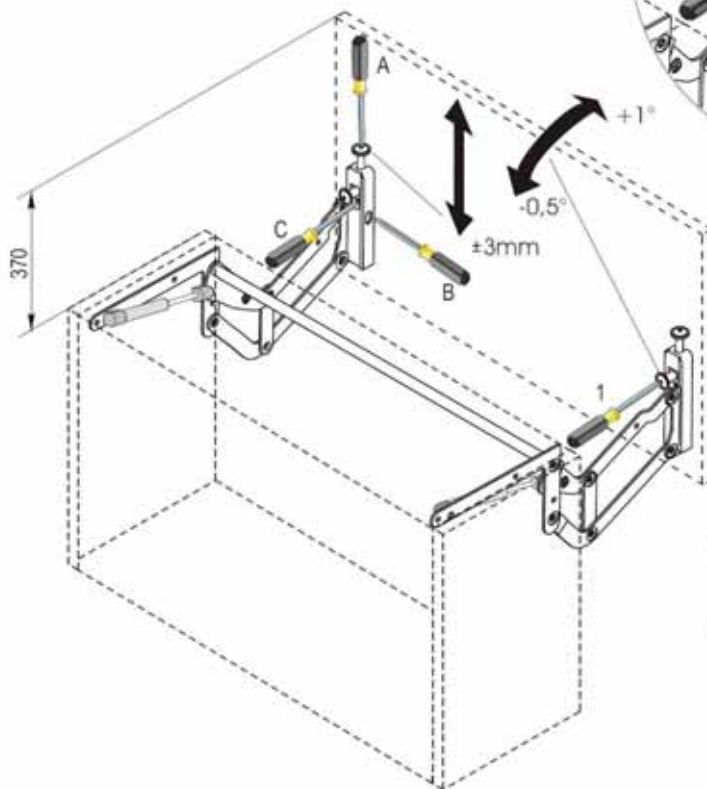

Zur Höhen-(A), Seiten-(B) und Neigungsverstellung(C) vorher die Befestigungsschraube (1) lösen.  
For height-(A), side-(B) and tilt adjustment(C) please unscrew the fixing screw (1)

