

# LAMONA

at the heart of the kitchen

## Downdraft Induction Hob - 60cm

LAM9501

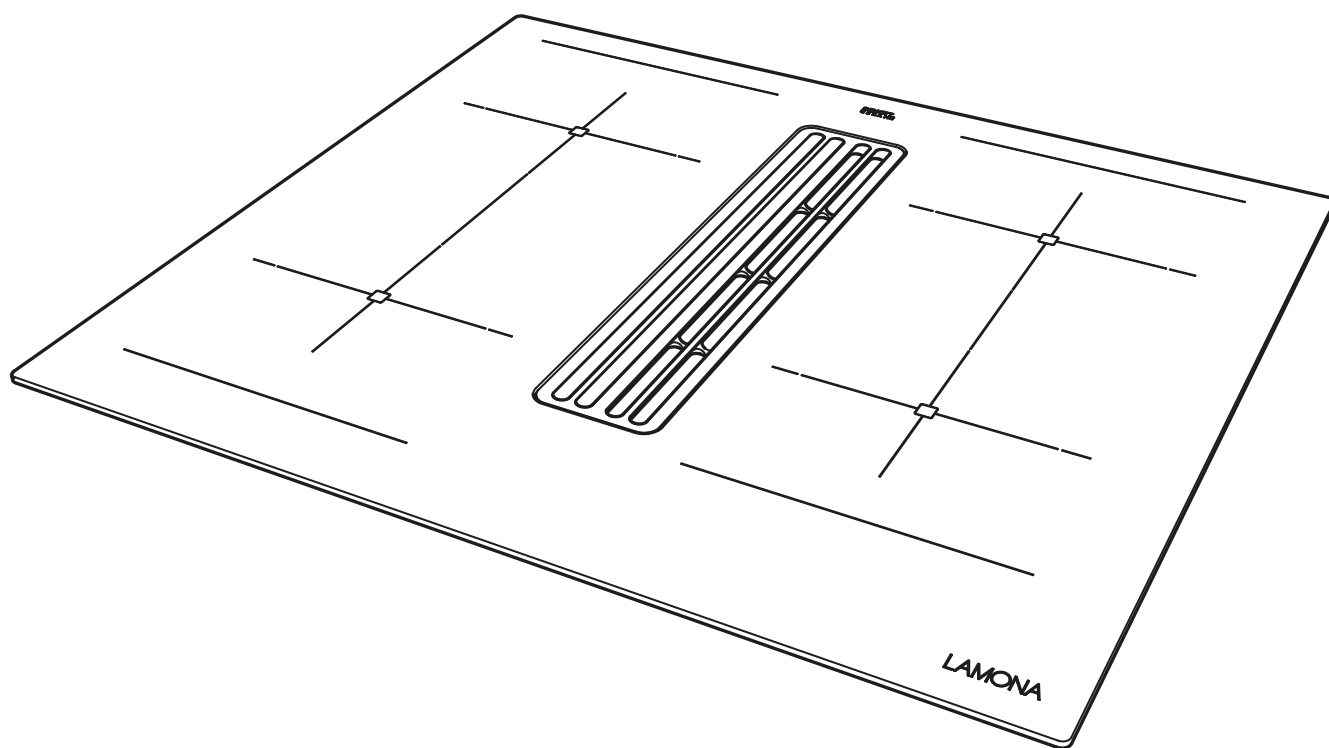

## User Instructions and Installation

ISSUE v3.6 100122

Register ✓  
my appliance

[www.howdens.com/appliance-registration](http://www.howdens.com/appliance-registration)



# Free 3 year guarantee

**Call now<sup>1</sup>**

Within the UK:

**0333 010 0009**

Within Republic of Ireland:

**01525 5752**

Alternatively, visit [www.howdens.com/appliance-registration](http://www.howdens.com/appliance-registration)

# LAMONA

**3 year guarantee available.**

**Register your appliance within 90 days<sup>2</sup>**

**By registering your appliance and creating an account, we will keep you up to date with the latest product information and notify you immediately of any important product updates**

<sup>1</sup>Lines are open Monday to Friday 9am to 5pm. Calls will be charged at your local rate and may be recorded and monitored for training and quality purposes.

<sup>2</sup>So that in the event of an important product update, or recall, we can contact you.

**Register**   
**my appliance**

---

# Welcome

Dear Customer

Congratulations on your choice of **LAMONA** domestic appliance.

- Please read these instructions before use to ensure safe and economical operation of the appliance.
- Please keep these instructions in a safe place for your future reference.
- If you have any questions, or if you are not sure about any information contained in this booklet please contact us - details at the end of the booklet.

This appliance is intended to be used in household and similar domestic applications, see guarantee page for definition of domestic use\*.

Throughout this manual the following symbols are used.

	Warning for hazardous situations with regard to life and property.		Information or useful hints and tips,
	Warning for electric shock.		Hot surface, risk of serious burning or scalding.

---

# Contents

<b>Warning and Safety information</b>	<b>p5</b>		
Before using the hob hood	p5		
SAFETY	p5		
General safety	p5		
General information about the hob	p5		
Children and general safety	p7		
Safety when working with electricity	p7		
Electrical connections	p7		
Waste electrical and electronic equipment	p7		
Danger of toxic fumes	p8		
<b>1. Downdraft induction hob overview</b>	<b>p8</b>	<b>4. Cleaning and care</b>	<b>p27</b>
<b>2. Controls overview</b>	<b>p9</b>	Glass hob	p27
Understanding the sensor field	p10	Specific soiling	p27
<b>3. Operating the hob hood</b>	<b>p10</b>	Hob fan	p28
The induction hob	p10	<b>5. Problem solving</b>	<b>p29</b>
Guide to selecting the right pan	p12	<b>6. Installation</b>	<b>p30</b>
Guide to the noises induction hob make	p13	Safety instructions for kitchen unit fitters	p30
Guide to induction hobs	p14	Ventilation	p30
How to cut power consumption	p15	Methods of extraction	p31
Power levels	p15	Replacing carbon filters	p31
Permanent pan recognition	p16	Worktop cut-out	p32
Operating the keys	p16	Important information	p32
Switching ON the hob and cooking zones	p16	Sealing of the hob	p32
Switching OFF a cooking zone	p17	Modifications required for a 600mm cabinet with door frontal	p33
Switching OFF the hob	p17	Modifications required for a standard 600mm cabinet (drawers)	p36
Pause function	p17	Modifications required for a 600mm handleless cabinet (profile fitting)	p37
Recall function	p18	Modifications required for a 600mm handleless cabinet (drawers)	p38
Childproof lock	p19	Modifications required for a combination hob hood >600mm cabinet	p39
Bridging function	p20	Air extraction system assembly	p44
Grill function	p20	Hob fan installation	p45
Automatic switch-off (timer)	p21	Electrical connection	p46
Minute minder	p22	Initial switching ON of the hob	p47
Keep-warm function	p22	<b>7. Technical specifications</b>	<b>p47</b>
Automatic boost function	p23	<b>8. Guarantee</b>	<b>p48</b>
Locking	p24		
Power boost	p24		
Power management	p24		
Using the fan	p25		
Switching the fan ON and OFF	p25		
Automatic function	p25		
Fan time lag	p26		
After run time	p26		

---

# Warning and Safety information



Please read these instructions. The manufacturer is not responsible if an incorrect installation and use causes injuries and/or damage. Always keep the instructions with the hob hood for future reference.

## Before using the hob hood

---

- Make sure that you have removed all packaging, wrappings, stickers and films from the hob hood.
- It is recommended that you clean the hob hood's surface before using for the first time.

## SAFETY

---

This appliance is for domestic extraction purposes only. It must not be used for other purposes. Commercial use will void the guarantee.

The manufacturer shall not be liable for any damage caused by improper use, installation or handling errors.

## General safety

---

This product is not intended to be used by persons with physical, sensory or mental disorders or unlearned or inexperienced people (including children) unless they are supervised by a person who will be responsible for their safety or who will instruct them accordingly in the use of the product.

- **Do not** operate the product if the power cable is damaged. Call a qualified service agent.
- **Do not** carry out any repairs or modifications on the product. However, you may remedy some the problems that do not require any repairs or modifications. See Problem solving.
- Never wash down the product with excessive amounts of water, as there is the risk of electric shock!
- Never use the product when your judgment or coordination is impaired by the use of alcohol and/or drugs.
- Repair procedures must always be performed by qualified service agents. The

manufacturer shall not be held responsible for damages arising from procedures carried out by unauthorised persons, which may also void the guarantee.

- Keep all ventilation slots clear of obstructions, as this may cause premature failure of the product.
- Make sure that the product function buttons are switched **OFF** after every use.
- Product must be installed by a person in accordance with the regulations in force otherwise, the guarantee may become void.

## General information about the hob

---

- Never allow the induction hob to operate unattended, as the high hob power setting results in extremely fast reactions.
- When cooking, pay attention to the heat-up speed of the cooking zones. Avoid boiling the pots dry as there is a risk of the pots overheating!
- Do not place empty pots and pans on cooking zones which have been switched ON.
- Take care when using simmering pans as simmering water may dry up unnoticed, resulting in damage to the pot and to the hob for which no liability will be assumed.
- It is essential that after using a cooking zone you switch it OFF with the respective minus key and not just with the pan recognition device.
- Overheated fats and oils may spontaneously ignite. Always supervise the preparation of food with fats and oils. Never extinguish ignited fats and oils with water! Switch the appliance OFF and then carefully cover the flame, for example with a lid or an extinguisher blanket.

---

## Warning and Safety information



- The glass ceramic surface of the hob is extremely robust. You should, however, avoid dropping hard objects onto the glass hob. Sharp objects which fall onto your hob might break it.
- There is a risk of electric shocks if the glass hob develops fractures, cracks, tears or damage of any other kind. Immediately switch OFF the appliance. Disconnect the fuse immediately and call Customer Service.
- If the hob cannot be switched OFF due to a defect in the sensor control immediately disconnect your appliance and call Customer Service.
- Take care when working with home appliances! Connection cables must not come into contact with hot cooking zones.
- Risk of fire: never store items on the hob.
- The glass hob should not be used as a storage area.
- Do not put aluminium foil or plastic onto the cooking zones. Keep everything which could melt, such as plastics, foil and in particular sugar and sugary foods away from hot cooking zones. Use a special glass scraper to immediately remove any sugar from the hob (when it is still hot) in order to avoid damaging the hob.
- Metal items (pots and pans, cutlery, etc.) must never be put down on the induction hob since they may become hot. Risk of burning!
- Do not place combustible, inflammable or heat deformable objects directly underneath the hob.
- Metal items worn on your body may become hot in the immediate vicinity of the induction hob. Caution! Risk of burns! Non-magnetisable objects (e.g. gold or silver rings) are not affected.
- Never use the cooking zones to heat up unopened tins of food or packaging made of material compounds. The power supply may cause them to burst!
- Keep the sensor keys clean since the appliance may consider dirt to be finger contact. Never put anything (pans, tea towels etc.) onto the sensor keys!
- If food boils over onto the sensor keys, we advise you to activate the OFF key.
- Hot pans and pots should not cover the sensor keys, since this will cause the appliance to switch OFF automatically.
- Place the pan as close to the centre of the cooking zone as possible.
- Whenever possible, use the back cooking zones for large pans so that the sensor keys are not heated up too much (touch control overheating; error message E2, touch control cut OFF).
- Activate the childproof lock if there are any pets in the home which could make contact with the hob.
- The induction hob may not be used when pyrolysis operation is taking place in a built-in oven below the hob.
- Never clean the glass hob with a steam cleaner or similar appliance!
- Make sure there are no items (e.g. cleaning cloths) right next to the hob extractor. They could be sucked in by the air current. Liquids and small items must always be kept away from the appliance.
- Do not operate the appliance without grease filter.
- Filter with too much fat deposits causes fire hazard!
- Constant supervision is essential when deep frying; flambéing is not permitted.
- A sufficient supply of inlet air must be provided when operating wood, coal, gas or oil heaters requiring a chimney. The permissible negative pressure which results from the hood in the location of the heaters requiring a chimney may not exceed 4 Pa (0.04 mbar) as this results in a risk of poisoning.
- Vapour also emits moisture into the air in the kitchen during the cooking process.

---

# Warning and Safety information



- Only a little moisture is removed from the vapours in the convection air mode. This is why a sufficient supply of fresh air must always be provided, e.g. by opening the window or using domestic ventilation systems.
- Always make sure that the indoor climate is normal and comfortable (45 - 60 % humidity).
- Switch the hob extractor down to a lower setting for around 20 minutes or activate the automatic delayed pause function every time the hob extractor is used in the convection air mode.

## Children and general safety

Electrical products can be dangerous to children. Keep children away from the product when it is operating and do not allow them to play with or near the product.

The packaging materials will be dangerous for children. Keep the packaging materials away from children. Please dispose of all parts of the packaging according to environmental standards.

## Safety when working with electricity

In case of any damage, switch OFF the product and disconnect it from the mains. To do this, turn OFF the fuse at the fuse box.

Make sure that fuse rating is compatible with the product.

## Electrical connection

- This appliance must be earthed.
- The electrical connection must comply with current local and national safety regulations (BS 7671 in the UK).
- **Do not** connect the appliance to the mains electricity by an extension lead or multi-adapter.
- The appliance must not be used with energy-saving plug devices. The appliance will not function correctly and may overheat.
- Check that the appliance is working correctly.

- The appliance is constructed in accordance with the relevant safety regulations.
- Connecting the appliances to the mains and repairing and servicing the appliances may only be carried out by a qualified electrician according to currently-valid safety regulations.
- For your own safety, **do not** allow anyone other than a qualified service technician to install, service or repair the product.
- If the mains supply cable of this appliance is damaged, it must be replaced by the manufacturer, the Customer Service of the manufacturer or by another qualified person to avoid danger.
- The appliance may not be operated with an external timer or an external telecontrol system.

## Waste Electrical and Electronic Equipment (WEEE)

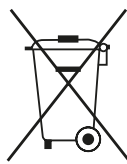

This product bears classification symbol for waste electrical and electronic equipment (WEEE). This product has been manufactured with high quality parts and materials which can be reused and are suitable for recycling. Do not dispose of the waste product with normal domestic and other wastes at the end of its service life. Take it to the collection centre for the recycling of electrical and electronic equipment. Please consult your local authorities to learn about these collection centres.

This appliance complies with all relevant safety standards.

# Warning and Safety information



## Danger of toxic fumes

Care should be taken when using the appliance in the same room or same area of the house at the same time as another heating appliance that depends on the air from the room.

If there is insufficient air, an under pressure will occur. The heating appliance may be starved of oxygen. This impairs combustion. Harmful gases could be drawn back into the room. Sufficient ventilation must be maintained by air inlets which cannot be blocked, e.g. in windows, doors and outside wall vents.

If the appliance is being operated in recirculation mode, whereby the air is redirected into the room, the above restrictions do not apply.

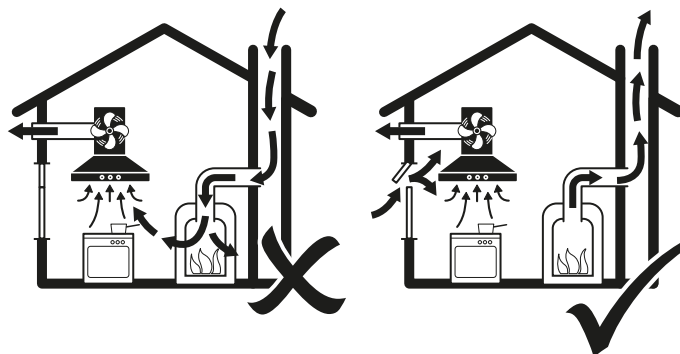

## 1. Downdraft Induction Hob overview

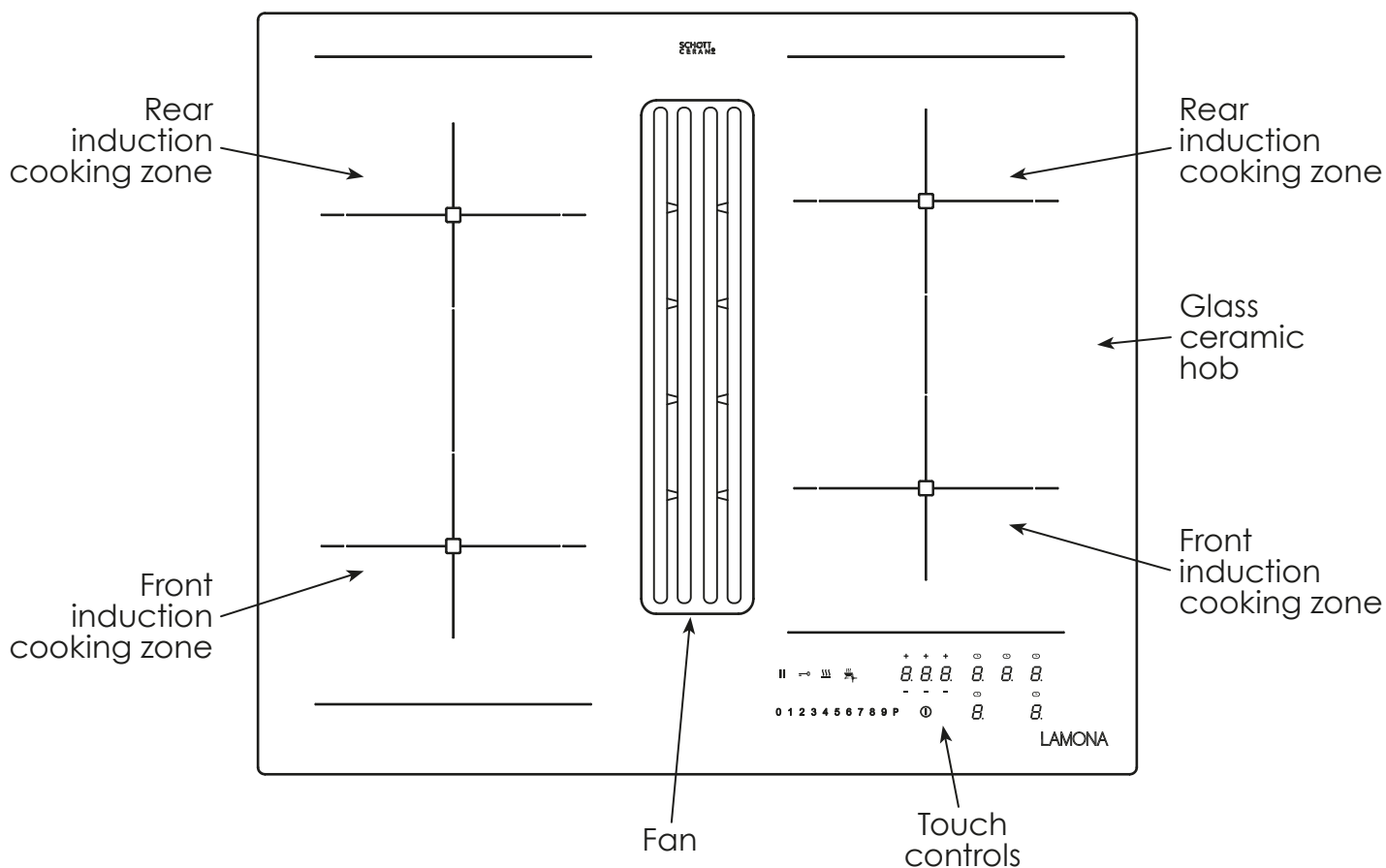



## 2. Controls overview

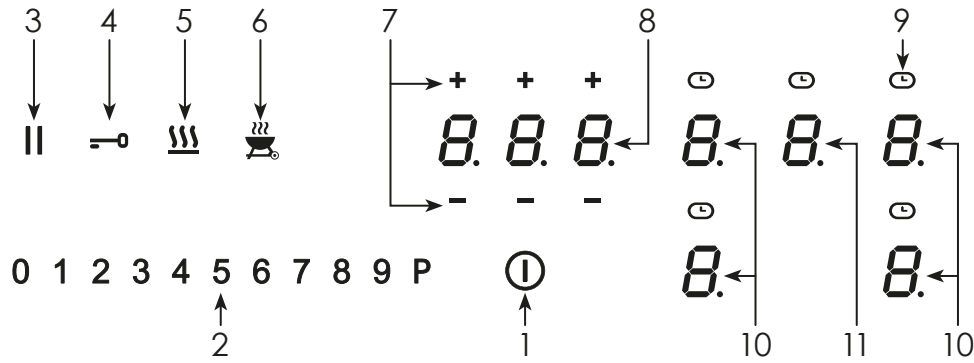

- |                 |                                 |
|-----------------|---------------------------------|
| 1. ON/OFF key   | 7. Minus key / Plus key - timer |
| 2. Sensor field | 8. Timer indication             |
| 3. Pause key    | 9. Display cooking zone timer   |
| 4. Lock key     | 10. Hob power setting           |
| 5. Warming key  | 11. Fan power setting           |
| 6. Grill key    |                                 |

 Most of the keys shown here will only become visible when the hob has been switched ON.

The glass hob is operated with touch control sensor keys. The sensor keys are operated as follows: lightly touch a symbol on the surface of the ceramic glass plate. A buzzer will indicate when the controls have been operated correctly.

The touch control sensor key will then be indicated as 'key'.

### Permanent pan recognition

If the hob has permanent pan recognition, a cooking setting can only be switched ON via the sensor field after a pan has been detected on the hob and the power display shows .

### ON/OFF key (1)

This key is used to switch the hob ON/OFF.

### Power boost in the sensor field

#### 0 1 2 3 4 5 6 7 8 9 (2)

The power boost setting makes additional power available for induction cooking zones or fan.

### Pause key (3)

The pause function can be used to briefly stop the cooking process.

### Recall function (3)

The most recent setting can be recovered if the hob is switched OFF unintentionally.

### Lock key (4)

The lock key can be used to lock all of the keys.

### Keep warm key (5)

To keep warm.

### Grill key (6)

Grill function with a griddle plate for induction.

### Minus key - / Plus key + (7)

These keys are used to set the timer and the automatic switch-off function of the cooking zones as well as the automatic delay stop of the fan.

### Symbols (9)

 Timer function, automatic switch-off device.

### Hob power setting display (10)

The hob power setting indicator shows the hob power setting which has been selected, or:

 Residual heat

 Power boost

 Pan recognition

 Automatic boost function

 Pause function

 Childproof lock

 Bridging function

 Grill function

 Keep-warm function

### Fan power setting display (11)

The power setting indicator shows the hob power setting which has been selected, or:

 Automatic function

 Replacing the carbon filter

## 2. Controls overview *(continued)*

### Understanding the sensor field

In principle, the sensor field functions the same as the touch controls; the only difference is that you can put your finger on the glass ceramic surface and then move it left and right.

The sensor field recognises this movement and raises or lowers the display setting (power level) in accordance with the movement.

0 1 2 3 4 5 6 7 8 9 P

Sensor field

#### What must be observed when operating sensor fields?

Your finger should not be placed flat onto the glass ceramic surface in order to avoid adjacent keys/sensor fields from reacting by mistake.

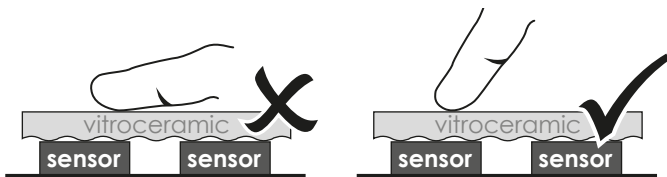

#### Press the sensor field lightly or move your finger around

You can press the sensor field very lightly with your finger; when this is done the setting on the display (power level) will gradually change. When you put your finger on the sensor field and then move it to the left or right, the display setting will change progressively.

The faster the movement, the faster the change in the display.

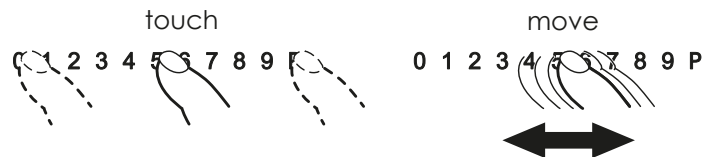

## 3. Operating the hob hood

### The induction hob

The hob is equipped with an induction cooking mode. An induction coil underneath the glass hob generates an electromagnetic alternating field which penetrates the glass ceramic and induces the heat-generating current in the pot base.

With an induction cooking zone the heat is no longer transferred from a heating element through the cooking pot into the food being cooked; instead the necessary heat is generated directly in the container by means of induction currents.

#### Pan recognition

**If a cooking zone is switched ON and there is no pan on the zone or if the pan is too small, there will be no transmission of power. A blinking  in the power level indicator points this out.**

**If a suitable pot or pan is placed on the cooking zone, the hob power setting will switch ON and the hob power setting indicator will light up. The power supply will be cut off when the pan is removed and the hob power setting indicator will indicate a blinking .**

**If the pots and pans placed on the cooking zone are of smaller dimension, and the pan recognition still switches ON, less power will be supplied.**

**The permanent pan recognition recognises on which cooking zone a pan is set up and shows a  in the corresponding hob power setting display.**

### 3. Operating the hob hood *(continued)*

#### Pan recognition limits

Cooking zone diameter (mm)	Recommended minimal diameter pan base (mm)
160	90
200	110
210 x 190	110

The base of pots and pans must be of a certain diameter; if it is not, the induction heat will not be switched ON. Always place pots and pans in the middle of a cooking zone in order to achieve the best efficiency.

**Important:** The minimum diameter required to activate the pan recognition device may vary according to the type of pot or pan used!

#### Operation time limit

The induction hob has an automatic time limit function.

The duration of continuous use of each cooking zone depends on the power level selected (see chart).

This requires that the setting of a respective cooking zone is not adjusted during use. If the operation time limit has been activated, the cooking zone will switch OFF, a short signal will sound and an **H** will appear in the display.

The automatic switch-OFF function overrules the operation time limit, i.e. the cooking zone is only switched OFF when the period of time of the automatic switch-off device has expired (e.g. automatic switch-off after 99 minutes and cooking level 9 is possible).

#### Operation time limit

Selected power level	Operation time limit in minutes
<b>U</b>	120
1	516
2	402
3	318
4	258
5	210
6	138
7	138
8	108
9	90
P	10

#### Other functions

If two or more sensor keys are pressed at the same time (e.g. when a pan is mistakenly put onto a sensor key) no function will be activated.

The symbol Er03 will blink and a time-limited continuous signal will sound. After a few seconds the appliance will switch OFF. Please remove the item located in front of the sensor keys.

To delete the symbol Er03 press the same key or switch the hob OFF and ON.

#### Protection against overheating (induction)

If the hob is used at full power for a longer period, it will not be possible to cool down the electronics system as required at a high room temperature.

In order to ensure that no excessive temperatures occur in the electronics system the power of the cooking zones may be reduced automatically. Should E2 be displayed frequently during normal use of the hob and at normal room temperature, it is likely that cooling is not sufficient.

This may occur if kitchen units have no openings. The installation may have to be checked (see the section on Ventilation).

### 3. Operating the hob hood *(continued)*

---

#### Guide to selecting the right pans for the induction hob

---

Choosing the right type of induction hob pans is key when cooking on a induction hob.

The right pan will be detected by the induction hob easily, heat the contents up quickly and will ensure the hob is quiet during use.

#### Do's

---

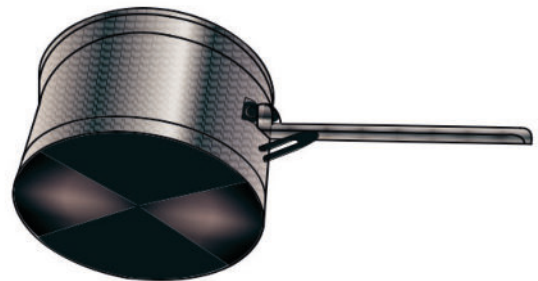

- Choose pans with a large diameter bottom similar to the actual pan diameter.
- Heavy pans are usually a good indication that the pans have got a high content of stainless steel and are good at being detected on an induction hob.
- Choose pans with a magnetic base and specifically marked for induction cooking.
- Choose pans with a flat stainless steel base pans with minimal engraving and patterns on them.

#### Don't

---

← 160mm →



← 125mm →



- Don't choose a pan with a base that is much smaller than the actual size of the pan itself.
- Try to stay clear of lightweight 'non-stick' pans, these tend to be made of aluminium and will have either a coating or insert of stainless steel on the base.



- Don't choose a pan with lots of engraving and patterns on the base, this will reduce the amount of stainless steel in contact with the actual induction hob and may not be detected on some of the zones.

These inserts can often be too small or thin to have enough stainless steel in them to allow the pan to be detected by the induction hob.

Good 'non-stick' induction pans are available and will have thick, flat stainless steel bases.

### 3. Operating the hob hood *(continued)*

---

#### Guide to the noises induction hobs make

---

Noises made by induction hobs can come from different causes. Noises can be caused by the hob itself making hums or buzzes, pans or the cooling fan that is built into the induction hob.

#### If you can hear...

---

**Cracking** – materials in your cookware are expanding.

**Whistling** – you are using a high-power level on your hob.

**Buzzing** – energy is transferring from your hob to your cookware.

**Clicking** – your hob is switching between electrical components.

**Humming** – your hob is cooling using its internal fan.

#### Induction hob noises

---

**The noises outlined above are not very loud.**

- Similar to your laptop when it is running.
- Not as loud as a washing machine.
- Not as loud as your cooker hood.
- Similar volume to a gas hob.

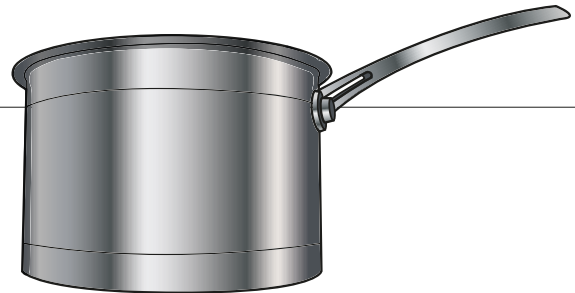

**All the noises above are normal and shows your hob is working correctly.**

#### Tips to reduce noise from your Induction hob

---

- Ensure that the induction hob pans that you use are large enough to cover the surface area of the zone.
- Use good quality cookware that is preferably made of ferromagnetic materials, see our induction hob pan guide.
- Ensure that your cookware's lids, handles and other pieces are well attached and fitted so that they do not create a noise when the pots are cooking.
- Ensure that the base of your pans and the surface of the hob are clean and dry.

**The noises made by induction hobs are harmless and part of the normal functioning.**

### 3. Operating the hob hood *(continued)*

---

#### Guide to induction hobs

---

#### What does power sharing really mean?

---

Induction hobs use a lot of electrical power. The power share feature spreads the power out so that the internals of the hob do not overwork and overheat.

Often this power sharing occurs when a pan with a low iron (magnetic) content is used. In order to induce sufficient power into the pan, the hob is having to deliver a higher power load than normal into that pan zone. The hob detects this and adjusts the power down to avoid overload and damage. It delivers the maximum power level possible for the pan being used.

On a standard four-zone hob, the two right-hand heating zones are linked (they share power) and the two left-hand ones are linked.

For example, when the hob has the correct amount of ventilation, and the correct pans are used...

- Can run with all four zones on high power (8 or 9), you may see zones flick between 8 and 9.
- Cannot run with zones on boost AND on high power. When boost is used, the other zone on that side will drop to low power.

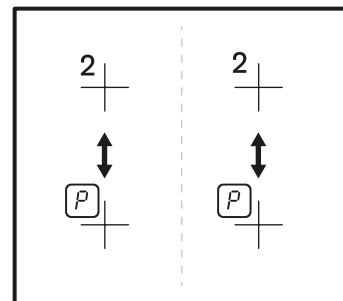
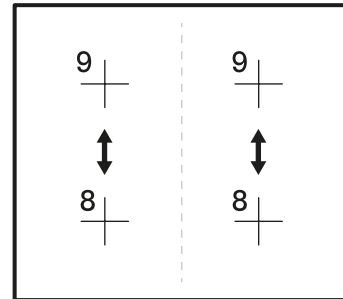

### 3. Operating the hob hood *(continued)*

#### How to cut power consumption

The following are a few useful hints to help you cut your consumption of energy and use your new induction hob and the cookware efficiently.

- The base of your cooking pots should be the same size as the cooking zone.
- When buying cooking pots, note that it is frequently the diameter of the top of the pot that is indicated. This is usually larger than the base of a pot.
- Pressure cookers are particularly low on energy and time required thanks to the pressure and the fact that they are tightly closed. Short cooking times mean that vitamins are preserved.
- Always make sure that there is sufficient fluid in your pressure cooker since the cooking zone and the cooker may be damaged as a result of overheating if the pressure cooker boils dry.
- Always close cooking pots with a suitable lid.
- Use the right pot for the quantity of food you are cooking. A large pot which is hardly filled will use up a lot of energy.

#### Power levels

The heating power of the cooking zones can be set at various power levels. In the chart you will find examples of how to use each setting.

Setting	Suitable for
0	OFF, using residual heat
<b>U</b>	Keep-warm function
1-2	Simmering small portions
3	Simmering level
4-5	Simmering larger quantities or roasting larger pieces of meat until they are cooked through
6	Roasting, getting juices
7-8	Roasting
9	Bringing to the boil, browning, roasting
P	Power boost (highest power output)

A higher power level may need to be selected for cooking pots without a lid.

#### Residual heat display **H**

The glass hob is equipped with an **H** as a residual heat indicator.

As long as the **H** lights up after the cooking zone has been switched OFF, the residual heat can be used for melting food or for keeping food warm.

The cooking zone may still be hot when the letter **H** no longer lights up. Risk of burns!

The glass ceramic is not directly heated in the case of an induction cooking zone; it is only heated up by heat reflected by the pan.

### 3. Operating the hob hood *(continued)*

#### Permanent pan recognition

If the hob has permanent pan recognition, a cooking setting can only be switched ON via the sensor field after a pan has been detected on the hob and the power display shows .

#### Operating the keys

The controls described here expect the pressing of a (selection) key to be followed by the pressing of a subsequent key. The next key will need to be pressed within 10 seconds, otherwise the selection will be deleted.

#### Switching ON the hob and cooking zones

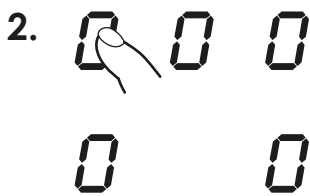

Suitable for induction cooking

1. Press the ON/OFF key (approx. 1 sec.) until the hob power setting  appears and a short signal will sound. The controls are ready for operation.

The permanent pan recognition recognizes on which cooking zone a pan is set up and shows a  in the corresponding hob power setting display.

2. Use the hob power setting display (as a key) to select a cooking zone. The stand-by dot of the cooking zone selected will light up.
3. The touch control must be activated immediately afterwards. A hob power setting will be switched ON.

	left	Power setting 
	centre	Power setting <b>5</b>
	right	Power setting <b>P*</b>

See the section on Understanding the sensor field.

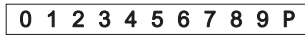
Press the respective sensor field  to change a hob power setting or to switch ON an additional cooking zone.

**Important:** the stand-by dot of the cooking zone selected must light up.

4. Immediately put cookware suitable for induction cooking onto the cooking zone. The pan recognition device will activate the induction coil. The pot or pan will be heated up.

As long as no cooking pot is placed onto the cooking zone, the display will alternate between the power level set and the symbol . If no pot is placed on the cooking zone it will switch OFF after 10 minutes for reasons of safety. Please refer to the Section on pan recognition.

\*The Power boost function is activated immediately.  
See section on Hob power setting.



### 3. Operating the hob hood *(continued)*

#### Switching OFF a cooking zone



Use the hob power setting display (as a key) to select a cooking zone.

The stand-by dot of the cooking zone selected must light up.

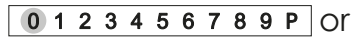

1a. Press the sensor field on the far left

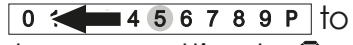

1b. Drag your finger to the left across the touch control  to reduce the hob power setting to .



#### Switching OFF the hob

2. Press the ON/OFF key of the hob . The hob will be switched OFF, irrespective of any settings.

**Please note:**

The hob will switch OFF automatically after 10 seconds when all the cooking zones are switched off manually (hob power setting ) and no key/sensor field is pressed afterwards.





#### Pause function II

The cooking process can be briefly interrupted with the pause function, e.g. if the doorbell rings. The pause function must be released in order to continue cooking at the same power level. If a timer has been set it will pause and will then continue.

This function is only available for 10 minutes for reasons of safety. The hob will then be switched OFF.

1. Pots and pans are on the cooking zones and the required power levels have been set.

2. Press the pause key . Instead of the selected hob power settings, the interval sign  will light up.

3. The interruption is ended by firstly pressing the pause key  and then pressing any other key (except the ON/OFF key).

The second key must be pressed within 10 seconds as the hob will otherwise be switched OFF.

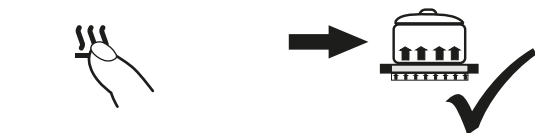

### 3. Operating the hob hood *(continued)*

#### Recall function II

The most recent setting can be recovered if the hob is switched OFF unintentionally.

The recall function only works if at least one cooking zone is switched ON.

1. The hob is inadvertently turned OFF by the ON/OFF key of the hob ①.

Within 6 seconds after turning it OFF, press the ON/OFF key of the hob ① again.

The pause key blinks.

2. The pause key II must be pressed immediately afterwards. The original cooking levels are restored. The cooking process continues.

#### What can be restored:

- Cooking levels of all cooking zones.
- Minutes and seconds of programmed timer functions.
- Automatic boost function.
- Power boost.

#### Not to be restored:

- Operation time limit (it is counted from 0).

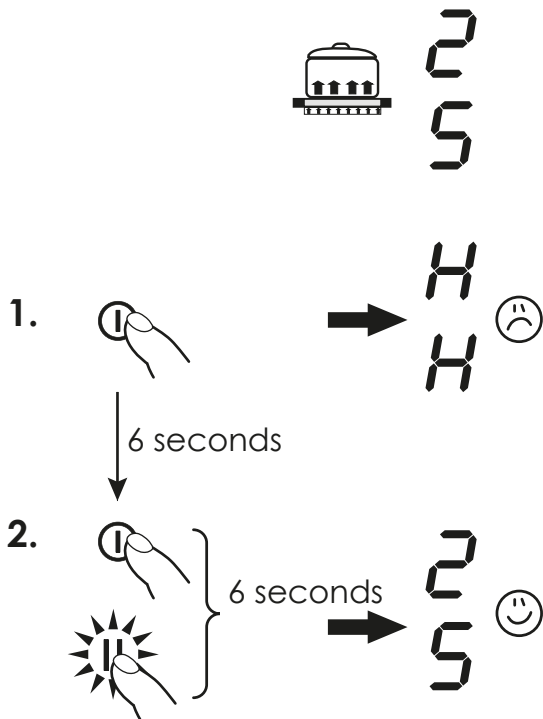





### 3. Operating the hob hood *(continued)*



#### Childproof lock

The childproof lock serves the purpose of preventing children from switching ON the induction hob either accidentally or intentionally. The controls are blocked here.

##### Switching ON the childproof lock

1. Press the ON/OFF key of the hob  (1sec.) until the hob power setting  appears.
2. Immediately afterwards press the hob power setting display and keep it pressed (for approx. 3 seconds) until the sensor field lights up from -P.
3. Immediately afterwards slide over the complete sensor field from -P to activate the childproof lock.  
The hob power setting indicators will show an  for child lock, the controls will be disabled and the hob will switch OFF.

##### Switching OFF the childproof lock

4. Press the ON/OFF key.
5. Immediately afterwards press the hob power setting display and keep it pressed (for approx. 3 seconds) until the sensor field lights up from -P.
6. Immediately afterwards slide over the complete sensor field from -P to deactivate the childproof lock.  
The  will go off.

##### Note:

- In the event of a power cut the childproof lock will not be cancelled.

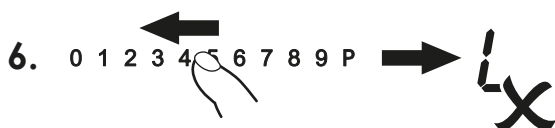
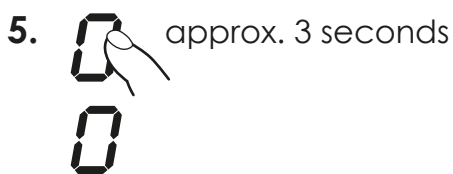
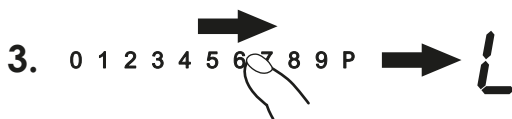
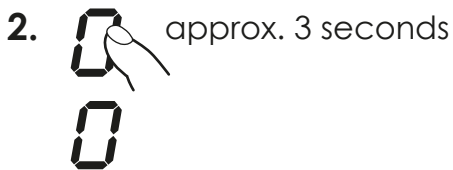

### 3. Operating the hob hood *(continued)*

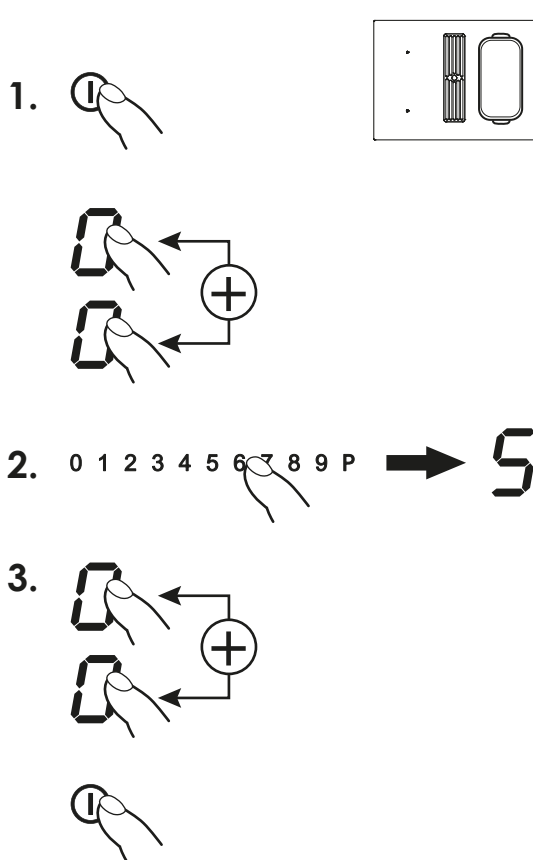

#### Bridging function

The front and the rear cooking zones may be activated together for a cooking process (bridging function). This enables larger cookware to be used. Both sides of the hob can be bridged.

1. Switch ON the hob.
2. Press the two cooking zone selection keys of the front and back cooking zones simultaneously to activate the bridging function. The bridging function has been switched ON and the back power level setting shows the bridge .
- Operation is carried out with the front power level setting and the sensor field.
3. Activate the front and back cooking zones simultaneously again or switch the hob OFF to deactivate the two power level settings (as a key).

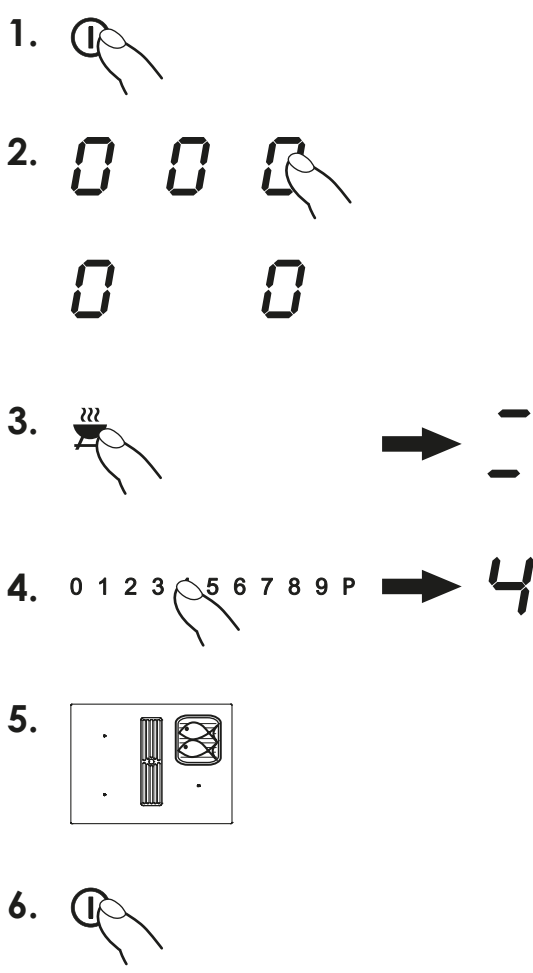

**Please note:**

The roaster or the pot will need to cover at least half of the cooking zones used in order to be recognised by the pan recognition device!



#### Grill function

Use the grill function with the recommended griddle plate for induction. This function is available on all 4 zones.

1. Switch ON the hob.
2. Use the front hob power setting display (as a key) to select a cooking zone. The stand-by dot of the cooking zone selected will light up.
3. Press the Grill key  to activate the grill function. The front and back cooking zones were switched together.
4. The touch control 0 1 2 3 4 5 6 7 8 9 P must be activated immediately afterwards. A hob power setting will be switched ON.
5. Put the griddle plate onto the cooking zone and insert the food to be grilled.
6. To switch OFF the grill function press the Grill key  or switch OFF the hob.

**Note:**

- Never operate the appliance unattended.
- Set the power levels just as you wish.

### 3. Operating the hob hood (continued)

#### Automatic switch-off (timer)

The automatic switch-off device is used to automatically switch OFF any cooking zone after an adjustable period of time.

Cooking times ranging from 0.01 to 9.59 (h.minutes) can be set.

1. Switch ON the hob.

2. Switch ON one or more cooking zones and select the required hob power settings.

3. Use the hob power setting display (as a key) to select a cooking zone. The stand-by dot of the cooking zone selected will light up.

Select the timer display and use the Plus key **+** or the Minus key **-** of the timer to set the required time.

Left position: Hours

Centre position: Every 10 minutes

Right position: Every minute

After a few seconds the entry will be taken over and the time will be running.

The timer symbol  of the cooking zone lights up.

4. The cooking zone will be switched OFF when the time has lapsed. A signal will sound for a while and can be switched OFF by pressing any key (except the ON/OFF key of the hob .

#### Note:

- Repeat steps 2 to 4 to program the automatic switch-off device for another cooking zone.
- To check the time that has lapsed (automatic switch-off) press the timer display (as a key). The setting displayed can be read and changed.
- Terminating the function of the timer: Select the respective cooking zone and press the minus key **-** to delete the time .
- If several cooking zones have been programmed with the automatic switch-off function, the timer display will always show the cooking zone with the shortest time.

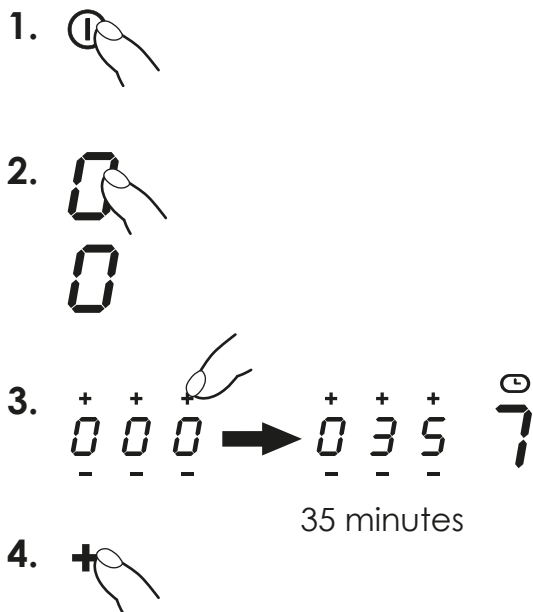

### 3. Operating the hob hood (continued)

- 1.
- 2.
- 3.

#### Minute minder

1. Switch ON the hob.
2. Don't select a cooking zone.  
Then use the Plus key + or the Minus key - to set the required time.
3. Once the time has lapsed a signal will sound for a while and can be switched OFF by pressing any key (except for the ON/OFF key of the hob ①).

#### Note:

- The minute minder will also remain in operation when the right or left side of the hob is switched OFF. Switch the left or right side of the hob ON to adjust the time.
- The minute minder will switch OFF after approx. 120 min. when the ① ON/OFF key is used for switching OFF.

- 1.
- 2.
- 3.

#### Keeping-warm function

With the keep-warm function you keep food warm. The respective cooking zone is operated at a low power level.

1. Cookware is placed on a cooking zone and a power level (e.g. 3) is selected.
2. By pressing the Warming key select the Keep-warm function.
3. To switch OFF the function press the sensor field on the far left or press the Warming key .

The keep-warm function is available for 120 minutes, after which the cooking zone will be switched OFF.

### 3. Operating the hob hood (continued)

#### Automatic boost function *A*

Food is parboiled at power level 9 with the automatic boost function. After a certain time, the power level will switch down automatically to a lower simmering setting (1 to 8).

When using the automatic boost function only the simmering setting with which the food is to be cooked through needs to be selected since the electronic unit switches down automatically.

The automatic boost function is suitable for dishes which are cold initially and are then heated up at high power. These dishes do not need to be constantly monitored when simmering (e.g. boiling meat for soups).

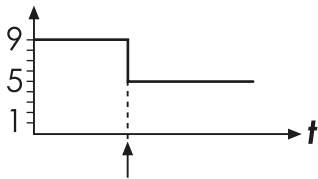

Press and keep pressed.  
(for approx. 3 seconds)



1. Switch ON the hob.

2. Press the sensor field **0 1 2 3 4 5 6 7 8 9 P** and keep it pressed (for approx. 3 seconds) to activate the function and immediately select a specific simmering setting:

<b>0 1 2 3 4 5 6 7 8 9 P</b>	left	Power setting <i>1</i>
<b>0 1 2 3 4 5 6 7 8 9 P</b>	centre	Power setting <i>5</i>
<b>0 1 2 3 4 5 6 7 8 9 P</b>	right	Power setting <i>9</i>

*A* and the selected simmering setting will blink alternately.

3. The automatic boost function will operate as programmed. After a certain time (see chart) the cooking process will be continued with the simmering setting.

The *A* symbol will go off.

#### Please note:

- The simmering setting can be raised while the automatic boost function is in operation. A reduction in the simmering setting will switch OFF the automatic boost function.

Cooking level Power level	Automatic boost function Time (min:sec)
1	00:48
2	02:24
3	03:50
4	05:12
5	06:48
6	02:00
7	02:48
8	03:36
9	-

### 3. Operating the hob hood (continued)

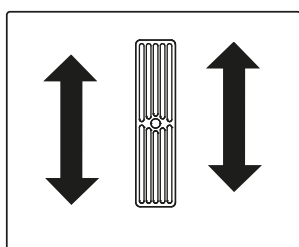
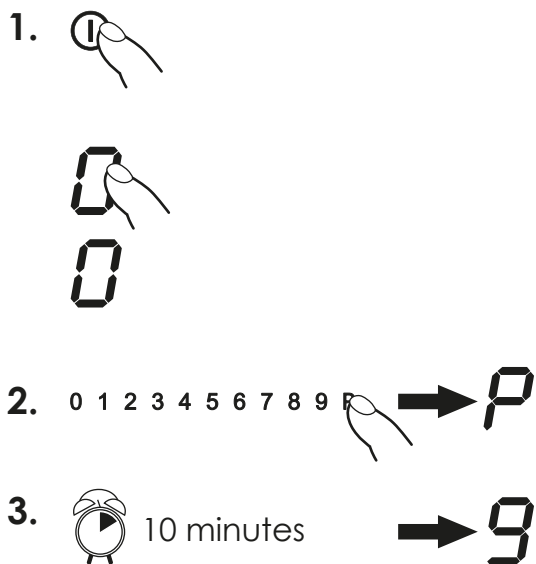
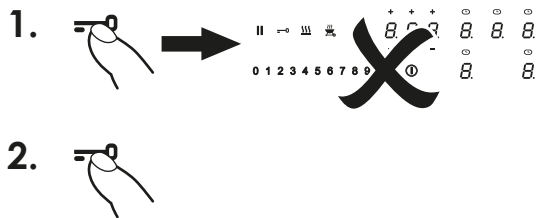

Modules (power management)

#### Locking

The lock can be used to lock key operation and cooking level settings. Only the ON/OFF key can be used to switch the hob OFF.

#### Activating the lock

1. Press the lock key . The lock key will light up brightly. The lock will now be activated.

#### Switching OFF the lock

2. Press the lock key . The lock key will light up with a dimmed light. The lock is now switched OFF.



#### Notes:

An activated lock will remain activated even if the hob is switched OFF. It must therefore be de-activated when cooking is re-commenced.

The activated lock will be cancelled, i.e. de-activated, in the event of a power failure and when the ON/OFF key of the hob  is used for switching OFF.

#### Power boost

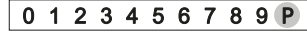
The power boost setting makes additional power available for induction cooking zones. A large quantity of water can be brought to the boil very quickly.

1. Switch ON the hob. Use the hob power setting display (as a key) to select a cooking zone. The stand-by dot of the cooking zone selected will light up.
2. Press the  sensor field on the far right. The power boost setting will be activated.
3. After 10 minutes the power boost setting will switch OFF automatically. The  will go OFF and the power level will switch down to .

#### Please note:

Press the sensor field to prematurely de-activate the power boost.

#### Power management

For technical reasons two cooking zones always comprise a module and have a maximum power level.

If this power range is exceeded when a higher hob power setting level or the power boost function is switched ON the power management system will reduce the hob power setting of the corresponding cooking zone of the module, see also 'Guide to induction hobs'.

The display for this cooking zone will initially blink, after which the highest-possible hob power setting will be consistently displayed.



### 3. Operating the hob hood (continued)

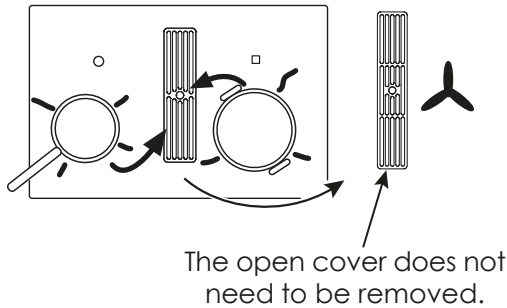

#### Using the fan

The fan is located in the middle of the hob with the extractor facing downwards.

The cover does not need to be removed from models with an open cover.

**Important: Do not put the cover onto the induction hob! Risk of burning!**

#### Switching the fan ON and OFF

1. Press the ON/OFF key **I** (approx. 1 second) until the fan hob power setting **0** appears and a short signal will sound. The controls are ready for operation.

2. Use the hob power setting display (as a key) to select a cooking zone. The standby dot will light up.

3. The touch control **0 1 2 3 4 5 6 7 8 9 P** must be activated immediately afterwards. A hob power setting will be switched ON.

<b>0 1 2 3 4 5 6 7 8 9 P</b>	left	Power setting <b>0</b>
<b>0 1 2 3 4 5 6 7 8 9 P</b>	centre	Power setting <b>5</b>
<b>0 1 2 3 4 5 6 7 8 9 P</b>	right	Power setting <b>P</b>

To change the fan level, select the fan display and then press the sensor field.

**Important:**

The stand-by dot of the cooking zone selected must light up.

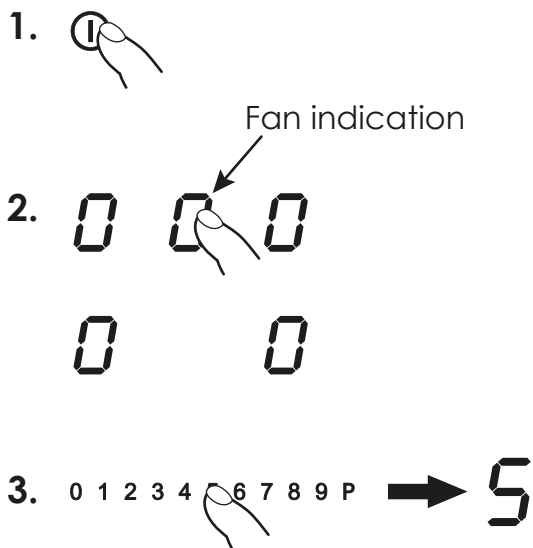

#### Automatic function

1. To select the automatic mode, press the fan display (as key) until an A for automatic mode is shown in the display.

The standby dot will light up.

2. Then select one or more cooking zones and set a power level.

3. The fan level is now automatically controlled according to the set power levels.

The automatic mode regulates slightly delayed and gradually according to the set power levels.

You can switch back to manual mode at any time by holding down the fan display or selecting the fan display and pressing the sensor field.

**Hint:** In order to ensure that extraction functions well with tall cooking pots (e.g. pots used for cooking asparagus), you can place a wooden spoon under the lid of the pot.

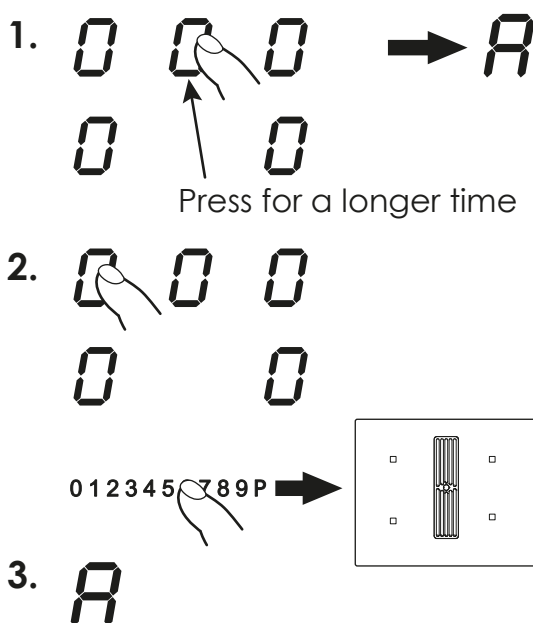

### 3. Operating the hob hood *(continued)*

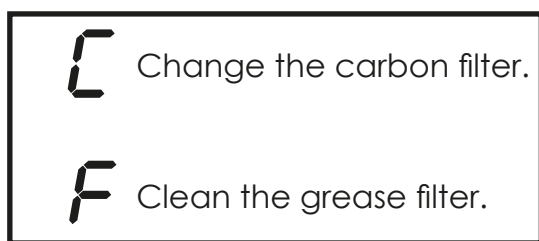
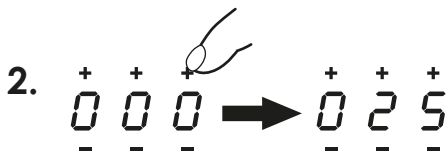

Press for 3 seconds



#### Fan time lag

The fan time lag is used after cooker in order to remove cooking odours. The filter is also dried in the fan.

##### Setting the fan time lag

1. Select the fan power setting.
2. Then use the Plus key **+** or the Minus key **-** of the timer to set the required time for the fan time lag.
  - Left position: Hours
  - Centre position: Every 10 minutes
  - Right position: Every minute
3. After a few seconds your input will be assumed and the procedure will have commenced.
  - The timer symbol  of the fan lights up.
4. The fan will be switched OFF when the time has lapsed. If a cooking zone is switched ON, the timer does not run until the cooking zone has been switched OFF. If the hob is switched OFF using the ON/OFF key during fan after run-time, the timer runs down to a low fan level.

#### After run time

The fan motor should continue operating for another 10-20 minutes every time the hob has been used for cooking. When the fan is switched OFF after having been in operation, an automatic after run time at a low setting will follow.

This guarantees optimal functioning and the removal of remaining cooking steam.

When using a recirculating air filter, please always allow for a stop delay time of 10 - 60 minutes in order to optimally remove cooking odours.

When the fan is switched ON again, in rare cases the odour molecules present in the filter may be combined with steam so that they are detected again. These remaining odours will disappear when the fan continues to operate.

**Important:** When the convection air mode is in operation, ventilation must be sufficient in order for the air humidity to be removed.

##### Replacement of the filter

If an existing carbon filter must be cleaned or replaced, this is indicated in the fan display by a **C** or **F**.

When the fan is switched ON, the display for a cooking process is deleted.

1. To reset the display, the fan display must be pressed for approx. 3 seconds.

If no carbon filter is used, the display indication **C** must also be reset.

---

## 4. Cleaning and care

- Switch the hob OFF and let it cool down before you clean it.
- Never clean the glass hob with a steam cleaner nor similar appliance!
- When cleaning make sure that you only wipe lightly over the ON/OFF key. The hob may otherwise be accidentally switched ON!

### Glass hob

---

#### Important!

Never use aggressive cleaning agents such as rough scouring agent, abrasive saucepan cleaners, rust and stain removers etc.

#### Cleaning after use

1. Always clean the entire hob when it has become soiled.  
It is recommended that you do so every time the hob is used. Use a damp cloth and a little washing up liquid for cleaning. Then dry the hob with a clean dry cloth to ensure that there is no detergent left on the surface of the hob.

#### Weekly cleaning

2. Clean the entire hob thoroughly once a week with commercial glass ceramic cleaning agents. Please follow the manufacturer's instructions carefully. When applied, the cleaning agent will coat the hob in a protective film which is resistant to water and dirt. All the dirt will remain on the film and can then easily be removed. Then rub the hob dry with a clean cloth. Make sure that no cleaning agent remains on the surface of the hob since this will react aggressively when the hob is heated up and will change the surface.

### Specific soiling

---

Heavy soiling and stains (lime scaling and shiny, mother-of-pearl-type stains) can best be removed when the hob is still slightly warm. Use glass ceramic cleaning agents to clean the hob. Proceed as outlined under weekly cleaning.

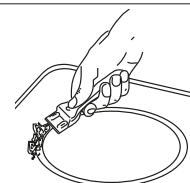

First soak **food which has boiled over** with a wet cloth and then remove remaining soiling with a special glass scraper for glass hobs. Then clean the hob again as described under weekly cleaning.

**Burnt sugar** and melted plastic must be removed immediately, when they are still hot, with a glass scraper. Then clean the hob again as described under weekly cleaning.

**Grains of sand** which may get onto the hob when you peel potatoes or clean lettuce may scratch the surface of the hob when you move pots around. Make sure that no grains of sand are left on the hob.

**Changes to the colour** of the ceramic surface have no effect on the function and stability of the glass ceramic.

These colour changes are not changes in the material but food residues which were not removed and which have burnt into the surface.

**Shining areas** are caused by wear from pan bottoms or unsuitable cleaning agents, especially when using cookware with aluminium bases or by unsuitable cleaning agents. They are difficult to remove with standard cleaning agents. You may need to repeat the cleaning process several times. In time, the decoration will wear OFF and dark stains will appear as a result of using aggressive cleaning agents and faulty pan bases.

## 4. Cleaning and care *(continued)*

---

### Hob fan

#### **Cleaning the metal grease filters**

Clean the metal grease filters in the dishwasher or in mild soapy water at least once a month or in the event of excessive grease deposits and/or intensive use.

To remove the filter, lift up the fan cover and lift the U-shaped stainless steel ventilation plate in the suction intake opening upwards to remove it from the fan. Now remove the filter. To do so, press the lock in the recessed handle downwards and remove the filter.

The filter can be rinsed in a dishwasher. Stand the filter upright in the dishwasher. Please use only rinse aid that is suitable for use with aluminium in order to avoid damaging and discolouring the filters.

Never rinse right next to glasses or light-coloured porcelain.

#### **Do not operate the fan without grease filters!**

After rinsing the filter, dry it and replace it in the fan. Please make sure that the recessed handle is visible after you have replaced the filter. If possible, wipe the easily accessible inside of the fan with a cloth dampened with detergent every time you replace a filter, while at the same time paying attention to protruding parts in the inside of the fan.

#### **Fan cleaning and care**

The fan is best cleaned every time you clean the filters.

Condensation water may collect under the filter after water has boiled rapidly with the lid of the pot removed. This is quite normal. The water should, however, be removed and the inside of the extraction housing cleaned.

The ventilation openings in the cover ensure that residual moisture resulting from cooking and cleaning can escape if necessary when the fan is not in operation and the cover is on.

Please clean the filter and the inside of the fan if unpleasant remaining odours escape.

The fan is best cleaned with a soft damp cloth and mild soapy water.

#### **Service**

The filter must remain accessible. Replace the charcoal filter mats of a charcoal filter every 5 to 24 months.

Part No: LAM2013 (Kit).

LAM2007 (Carbon Filter).

---

## 5. Problem solving

Interference with and repairs to the appliance by unqualified persons are dangerous as they can result in an electric shock or a short circuit. Do not interfere with or try to repair the appliance; this could cause injury to persons and damage to the appliance. Always have such work done by an expert, e.g. a Customer Service technician.

### **Please note:**

If your appliance is faulty, please check whether you can rectify the problem yourself by consulting these instructions for use.

**You may be able to rectify some problems yourself. They are described below.**

### **The fuses blow regularly?**

Contact a technical customer service or an electrician!

### **You can't switch your induction hob on?**

- Has the wiring system (fuse box) in the house blown a fuse?
- Has the hob been connected to the mains?
- Is the childproof lock activated, i.e. does the display show an 'L'?
- Are the sensor keys partly covered by a damp cloth, fluid or a metallic object? Please rectify.
- Are you using unsuitable cookware? See 'Guide for selecting the right pan'.

### **Error code E2 is indicated?**

The electronic unit is too hot. Check the installation of the hob. Make sure that there is sufficient ventilation.

See the section on 'Protection against overheating'. See the section on 'Ventilation'.

### **Error code E8 is indicated?**

Fault on the left or right fan. The suction opening is blocked or covered or the fan is defect.

Check the installation of the hob. Make sure that there is sufficient ventilation.

See the section on 'Protection against overheating'. See the section on 'Ventilation'.

### **Error code U400 is indicated?**

The hob has been incorrectly connected. The controls will switch OFF after 1sec. and a continuous signal will sound.

Connect the appliance to the appropriate power supply.

### **An error code (ERxx or Ex) is indicated?**

The appliance has developed a technical defect. Please call Customer Service.

### **The symbol will blink and a time-limited continuous signal will sound.**

Food which has boiled over, cookware or other items are causing the touch control sensor keys to be consistently operated.

**Remedy:** Clean the surface or remove the item. To delete the symbol  press the same key or switch the hob OFF and ON.

### **The pot sign appears?**

A cooking zone has been switched ON and the hob is expecting a suitable pot or pan to be placed on the cooking zone (pan recognition). Only when a pot has been placed on the cooking zone will power be supplied.

### **The pot sign still appears, even though a pot or pan was placed on the hob?**

The cookware is unsuitable for induction cooking or the pot or pan is too small.

Is the cookware you are using making noises?

This is due to technical reasons; the induction hob and the pot are not at risk.

### **Does the cooling fan still operate after it has been switched OFF?**

This is normal since the electronic unit is being cooled down.

### **Is the hob making noises (clicking or cracking sounds)?**

This is for technical reasons and cannot be avoided. See 'Guide to the noises induction hobs make'.

### **Does the hob have tears or cracks?**

There is a risk of electric shocks if the glass hob develops fractures, cracks, tears or damage of any other kind. Immediately switch OFF the appliance. Disconnect the fuse immediately and call Customer Service.

## 6. Installation

### Safety instructions for kitchen unit fitters

- Veneers, adhesives and plastic surfaces of surrounding furniture must be temperature resistant (at least 75°C). If the veneers and surfaces are not sufficiently heat resistant they may become deformed.
- Ensure that all live connections are safely insulated when installing the hob.
- Cover strips between the wall and the worktop behind the hob which are made of solid wood are permissible as long as minimum clearances in accordance with the installation diagrams are maintained.
- Minimum clearances of the hob cut-out towards the rear are to be maintained in accordance with the installation diagram.
- For installation directly next to a tall cupboard, a safety distance of at least 50mm must be ensured. The side surface of the tall cupboard should be fitted with heat resistant material. Due to working requirements, however, the distance should be at least 300mm.
- The clearance between the hob and an extraction hood must be at least as large as that stipulated in the assembly instructions for the cooker hood.
- The packaging materials (plastic foil, polystyrene, nails etc.) must be kept out of reach of children as these parts are potentially dangerous. Small parts can be swallowed and there is a danger of plastic sheeting causing suffocation.

### Ventilation

- The induction hob is fitted with a fan that switches ON and OFF automatically. The fan starts slowly when the electronic system temperatures exceed a specific limit. When the induction hob is used intensively, the fan will switch to a greater velocity. Once the electronic system has cooled down sufficiently, the fan will reduce its velocity and switch OFF again automatically.
- Clearance between the induction hob and kitchen furniture or built-in units must provide for sufficient ventilation of the induction hob.
- If the power level of a cooking zone is automatically raised or lowered (see section on thermal cut-off device) it is likely that the cooling system does not cool sufficiently. In this case we recommend that the back wall of the bottom kitchen unit in the area of the worktop cut-out be opened and that the front transverse strip of the unit be removed over the entire width of the appliance in order to promote the circulation of air.

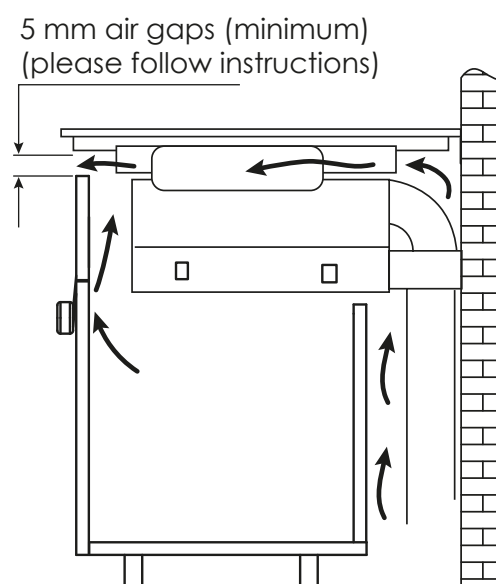

In order to better ventilate the hob, an air gap of 5mm should be left at the front.

## 6. Installation (continued)

### Methods of extraction

The very best method of clearing the kitchen of unwanted odours is by connecting the appliance to an exhaust duct and venting to the outside atmosphere via an exterior wall. (Suitable ducting kits may be purchased from your local Howdens depot or online.) You do not need carbon filters when using the external ducting mode.

#### Extraction via exhaust ducting (vented outside)

##### Ducting mode

(No carbon filter required)

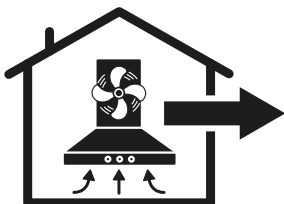

Ducting kits supplied separately.

Never use the hood in areas where devices with exhaust pipes connected to the outside are already operating unless perfect ventilation can be guaranteed.

There must be adequate ventilation in the room when the cooker hood is used at the same time as an appliance burning gas or other fuels.

- Connect the external ducting kit to the outlet of the cooker hood.

**⚠ Carbon filters are not required if the cooker hood is to be ducted out.**

##### Tips for ducting optimal air extraction:

- Keep duct work short and straight.
- Do not reduce the size or diameter of the duct.
- Keep ductwork taut to minimise pressure loss.

#### Extraction via recirculation (vented internally)

##### Recirculation mode (using carbon filters)



For extraction via recirculation, install carbon filters. These can be ordered separately from your local Howdens depot or online.

##### Replacing carbon filters

**⚠ Ensure cooker hood is switched off before installing/changing the carbon filters.**

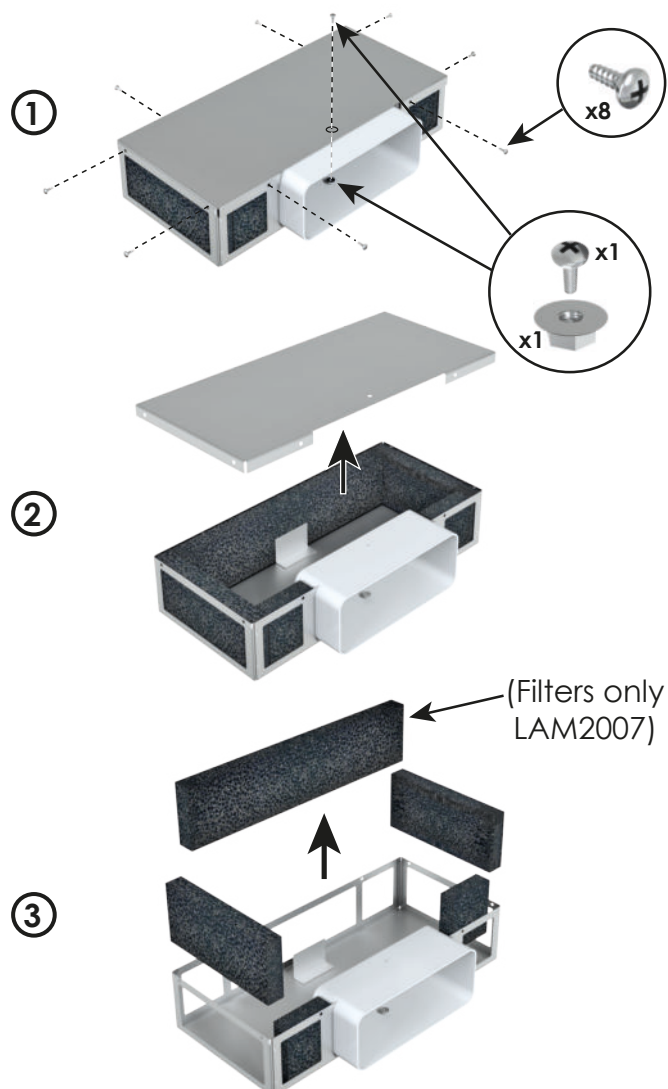

## 6. Installation (continued)

### Worktop cut-out, (560x490mm)

Cut out the worktop recess accurately with a good, straight saw blade or recessing machine. The cut edges should then be sealed so that no moisture can penetrate.

The area is cut out as illustrated. The glass hob must have a level and flush bearing. Any distortion may lead to fracture of the glass panel. Make sure that the sealing of the hob is properly seated.

#### Important:

**There is a risk of breakage if the hob is canted or subjected to stress during installation!**

\*200mm recommended for safe practical use.

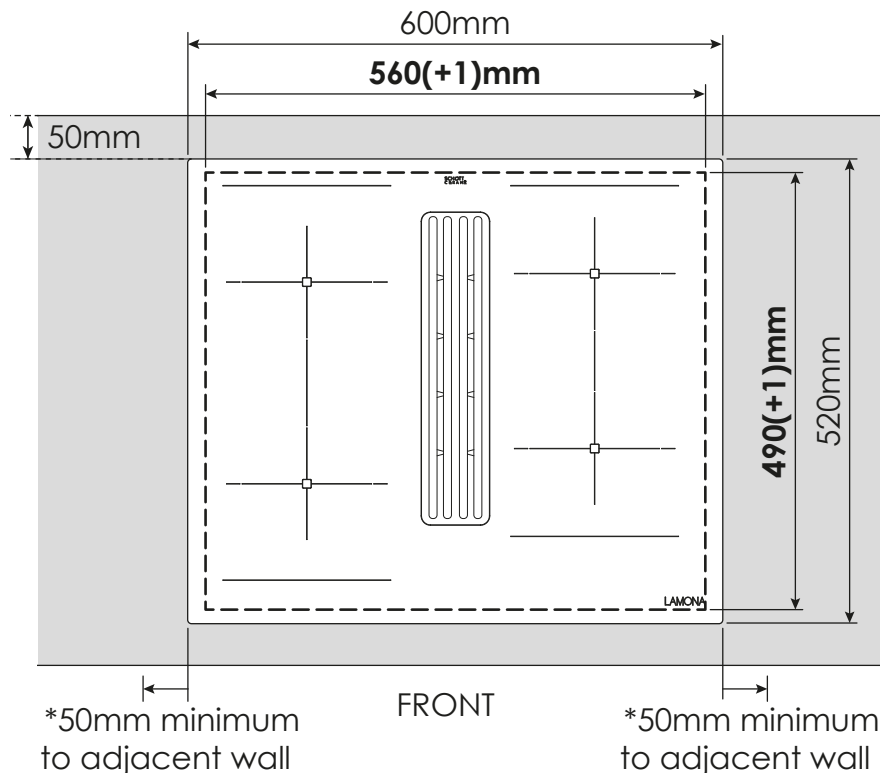

### Important information

- Avoid excessive thermal development from below e.g. from a baking oven without a cross flow cooling device.
- The induction hob may not be used when pyrolysis operation is taking place in a built-in oven fitted below hob.
- When installing the appliance on top of a drawer it is essential to ensure that no sharp items are stored in the drawer since these could become bent on the underside of the hob and prevent the drawer from being opened and closed.
- If a shelf has been inserted underneath the hob, there must be a clearance of at least 20mm to the underside of the hob in order to ensure that the hob is sufficiently ventilated.
- The hob may not be installed above refrigerators, freezers, dishwashers, washing machines or dryers.
- To avoid danger of fire, make sure that no combustible objects which could easily catch fire or become deformed on exposure to heat are directly next to or under the surface.

### Sealing of the hob

Before installation, correctly insert the sealing unit delivered with the hob.

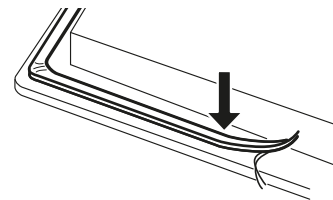

- No liquids may penetrate between the edge of the hob and the worktop or between the hob and the wall and come into contact with any electrical appliances.
- When installing a hob into an uneven worktop, e.g. with a ceramic or similar covering (tiles etc.), the seal on the hob is to be removed and the seal between the hob and worktop made with plastic sealing materials (putty).
- The hob must under no circumstances be sealed with silicone sealant! This would make it impossible to remove the hob at a later date without damaging it.



## 6. Installation - Modifications required for a 600mm cabinet with door frontal

### Remove the back panel

Keep the back panel for later use.

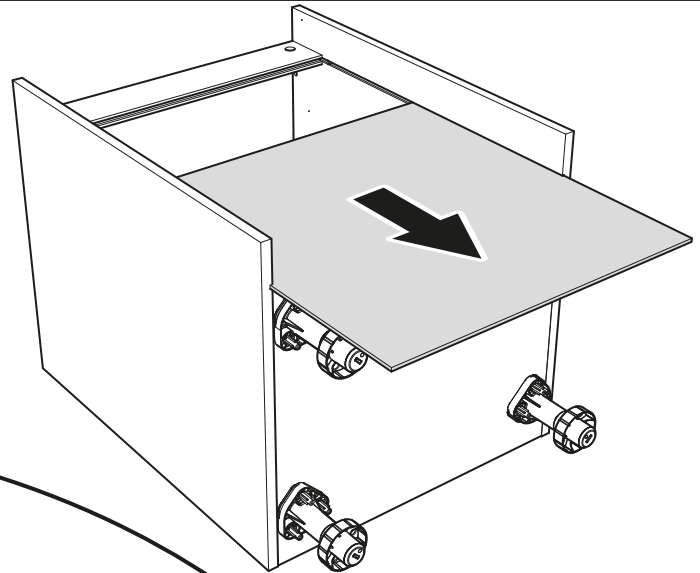

### ② Modify base

Cut out a section in the bottom shelf for ducting (to suit position of hob and ducting).

\*Dimensions are guides only.

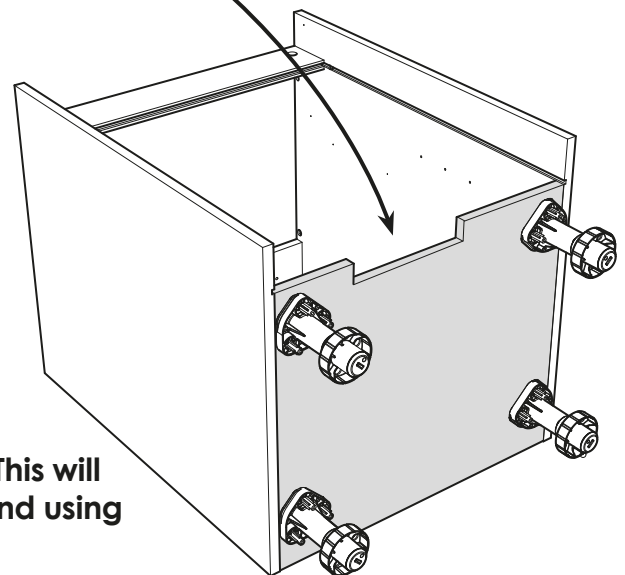
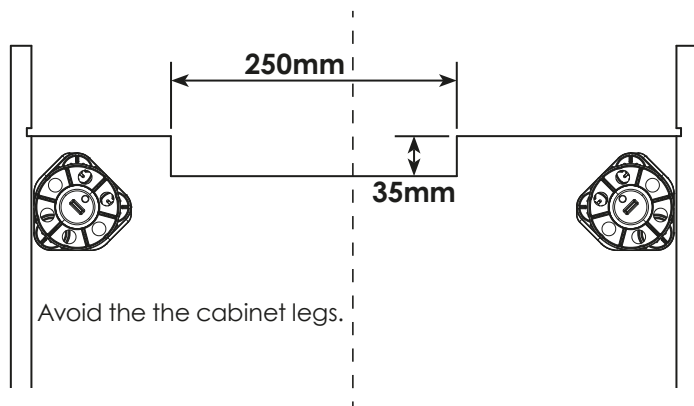

### ③ Make front support panel

Fit support panel flush with the top of the cabinet. **This will be visible when complete, therefore we recommend using a decor panel of some sort.**

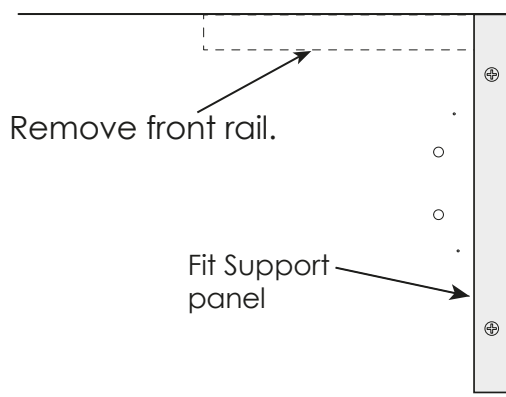
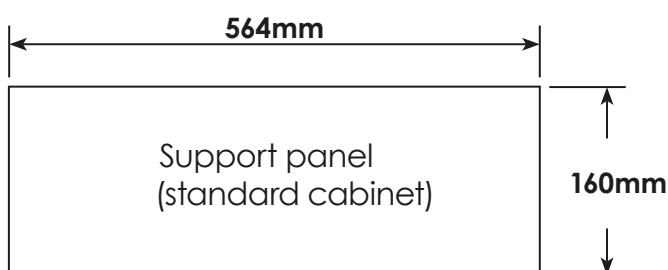

\*Dimensions are guides only.

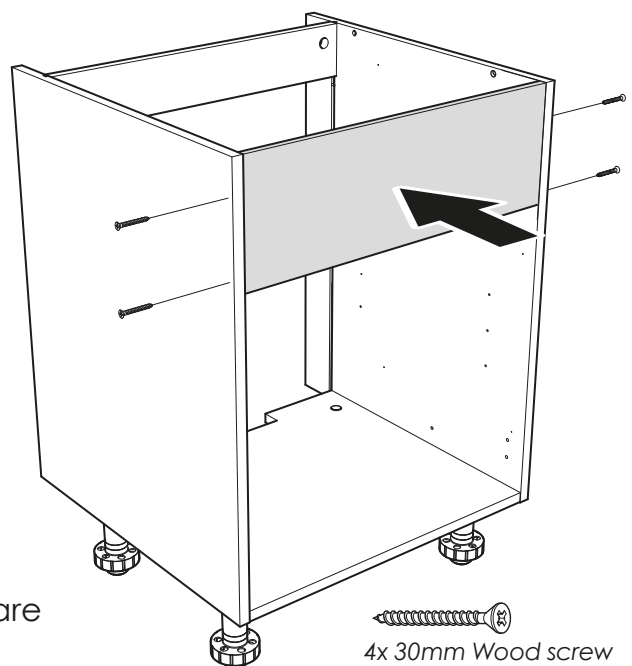

4x 30mm Wood screw  
(not supplied)

## 6. Installation - Modifications required for a 600mm cabinet with door frontal

### ④ Remove and cut down back rail

⚠️ Avoid metal tangs on wider cabinets.

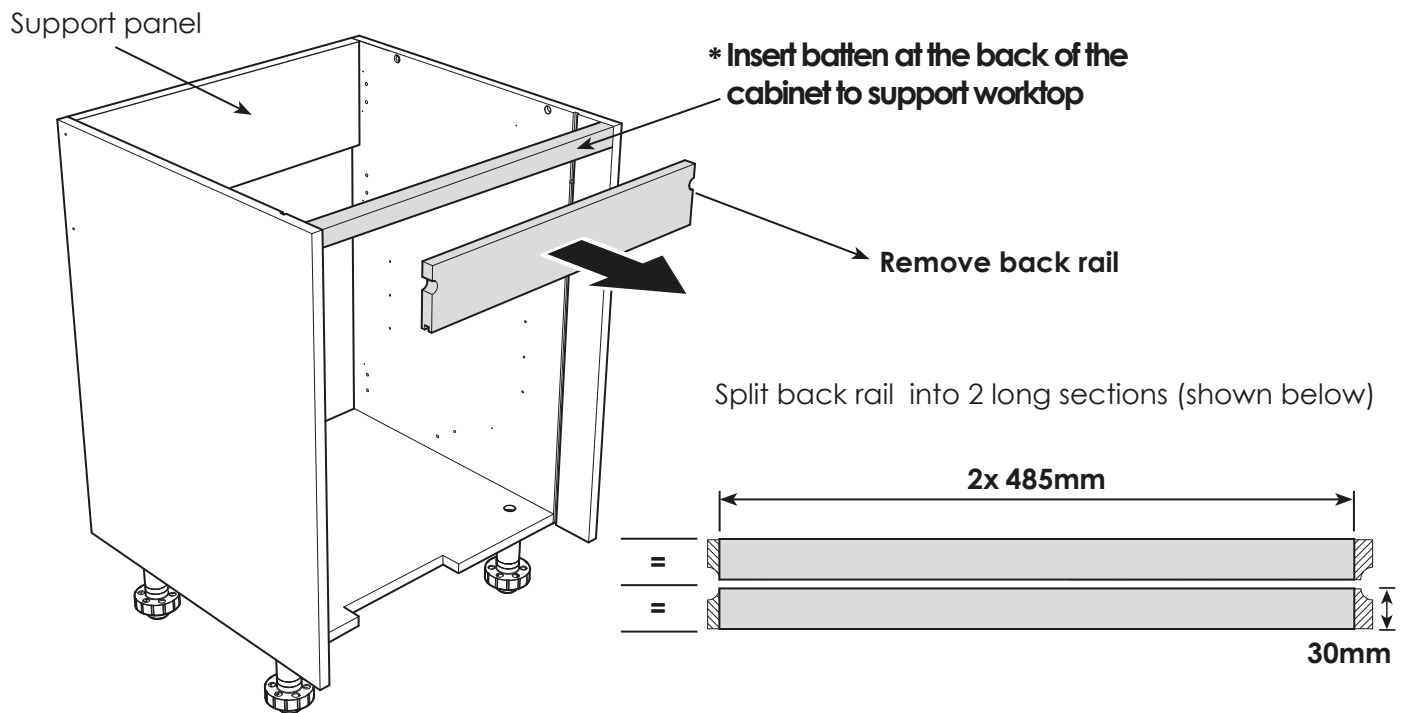

### ⑤ Fit back panel supports to the cabinet sides

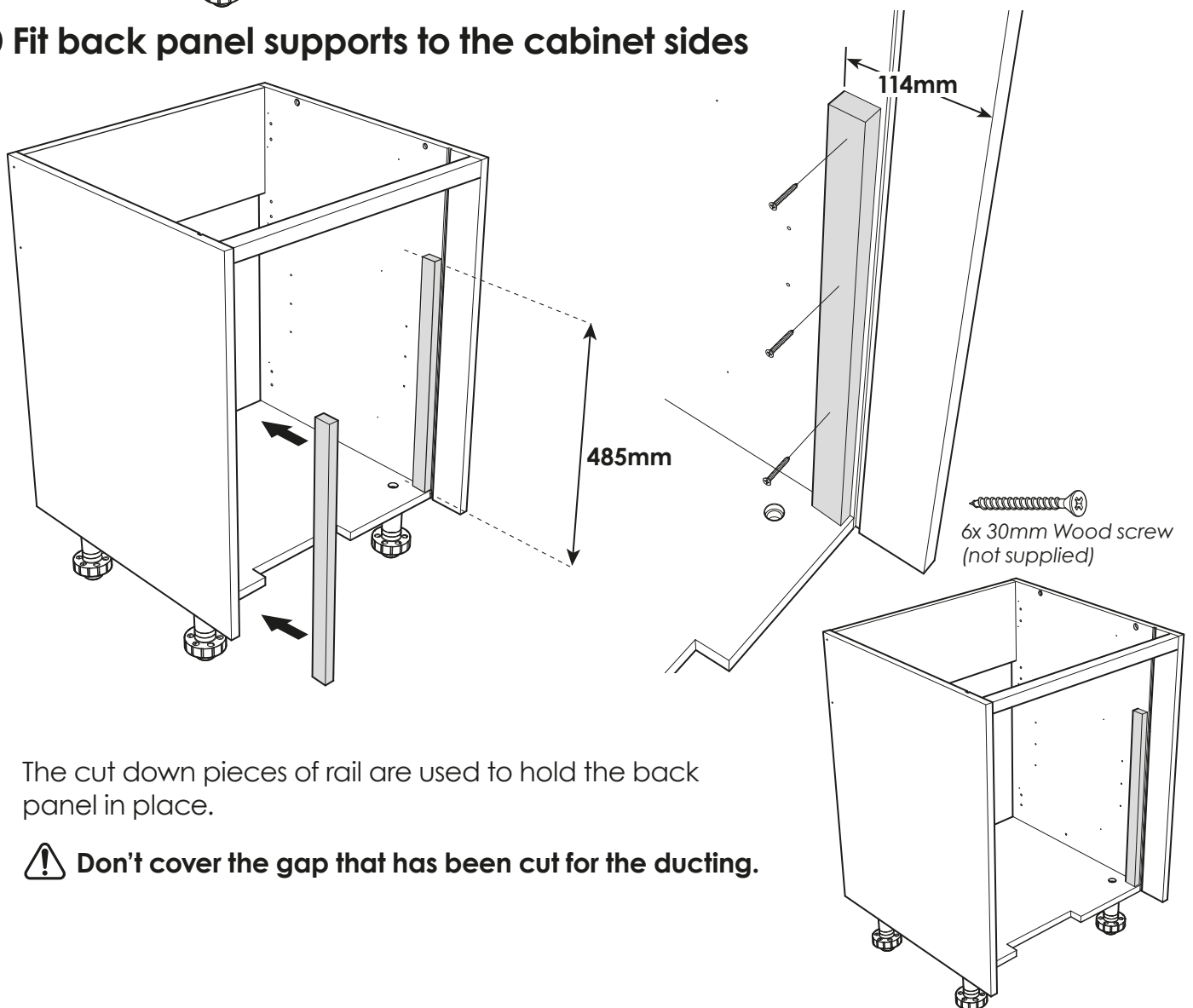

The cut down pieces of rail are used to hold the back panel in place.

## 6. Installation - Modifications required for a 600mm cabinet with door frontal

### ⑥ Fit back panel

Cut down the back the panel and screw to newly fitted support rails.

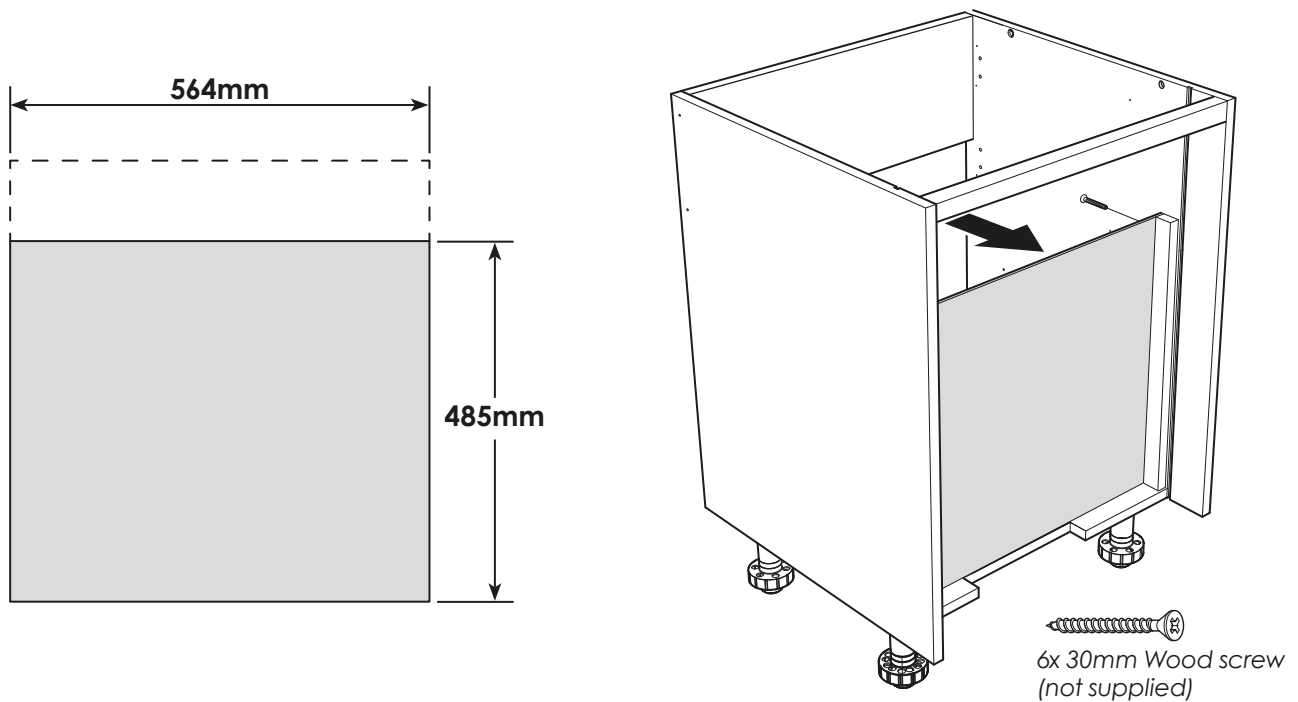

### Fit door frontal

Use steps 1-6.

Drill new hinge pot.

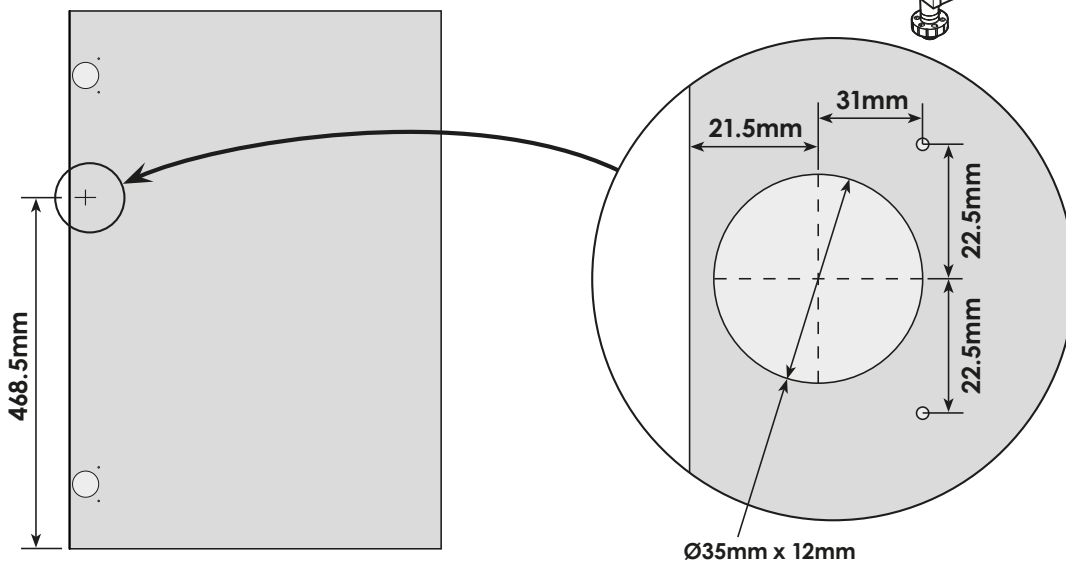
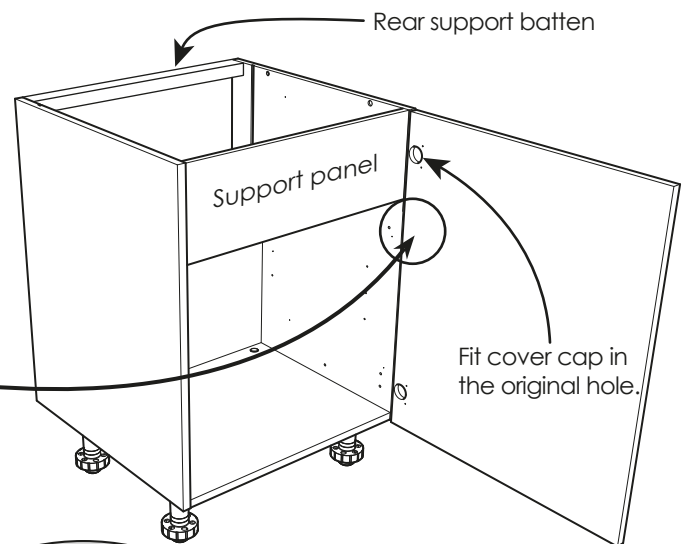

## 6. Installation - Modifications required for a standard 600mm cabinet (Drawers)

### Fitting drawers using a dummy drawer

Use steps 1-6.

Fix the dummy drawer frontal onto the support panel from inside the cabinet using suitable screws.

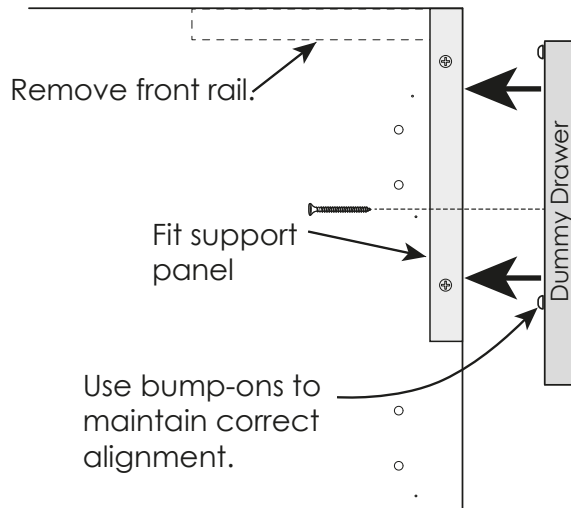
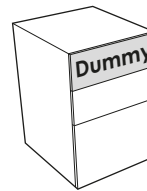

**\*See Howdens Kitchen Installation Manual for drawer fixing and runner installation set-ups.**

### Example drawer runner installation

600 3 Drawer

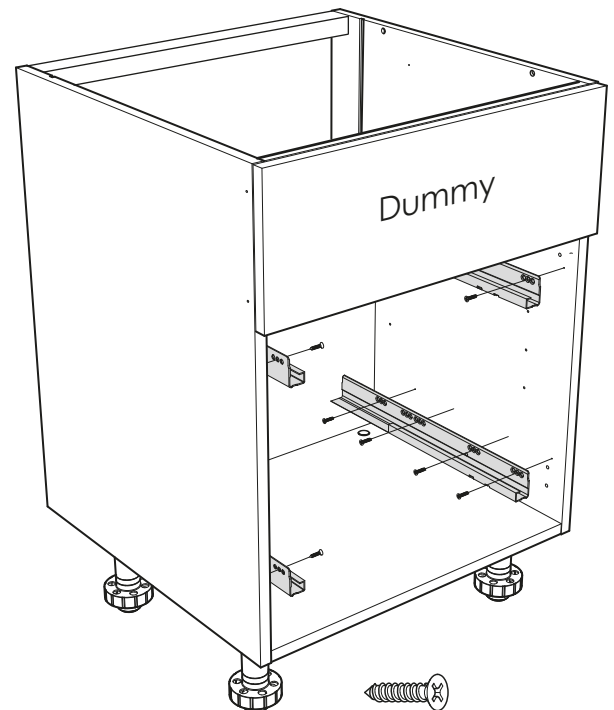
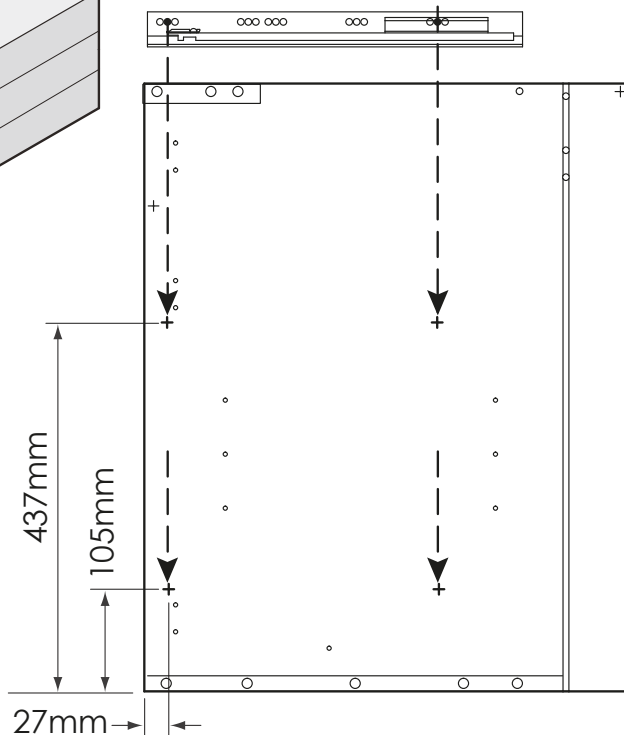
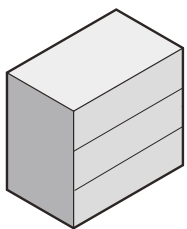

16x Suitable screws

## 6. Modifications required for a 600mm handleless cabinet (Profile fitting)

### Fitting door frontals to Handleless cabinet (profile)

Use steps 1-6.

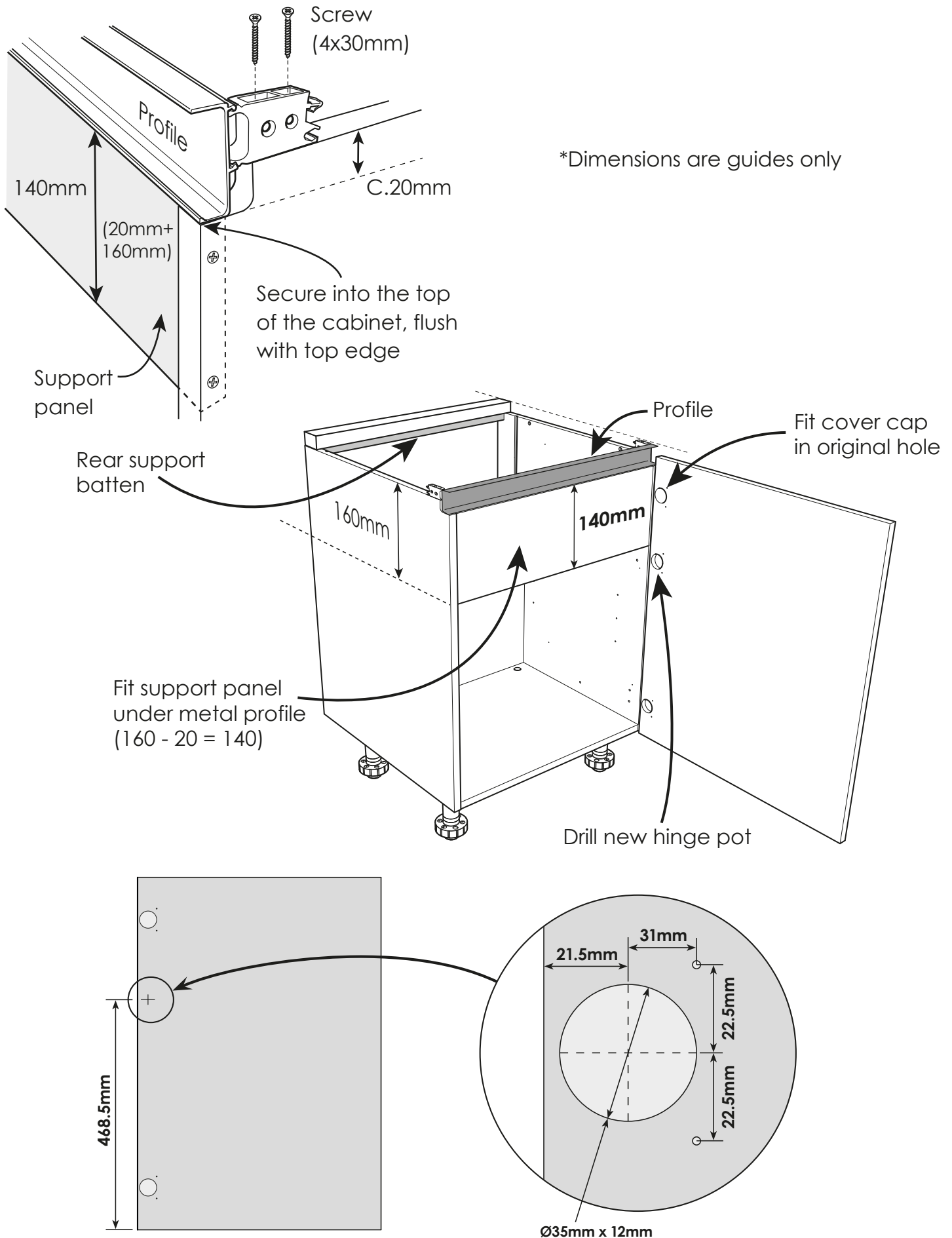

## 6. Installation - Modifications required for a 600mm handleless cabinet (drawers)

### Fitting with drawers

Fix the dummy drawer frontal onto the support panel from inside the cabinet using suitable screws.

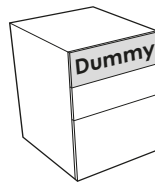

Rear support batten

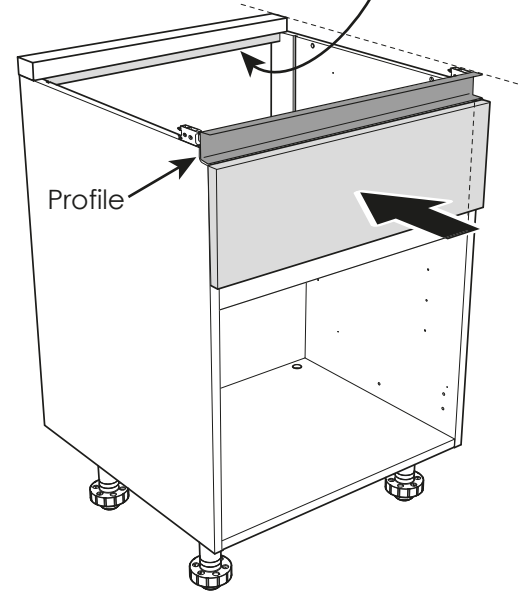
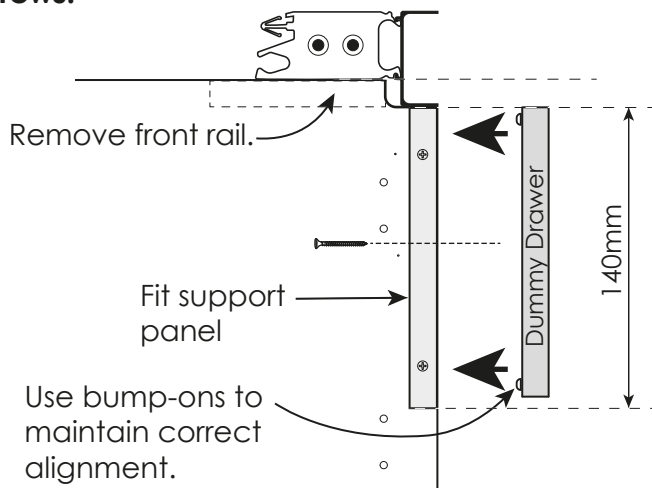

### Example drawer runner installation.

600 3 Drawer

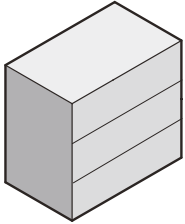

**\*See Howdens Kitchen Installation Manual for drawer fixing and running installation set-ups.**

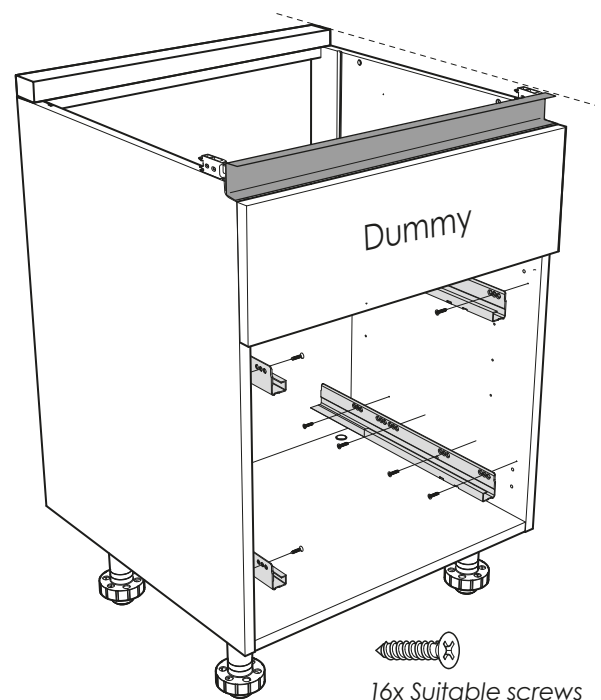
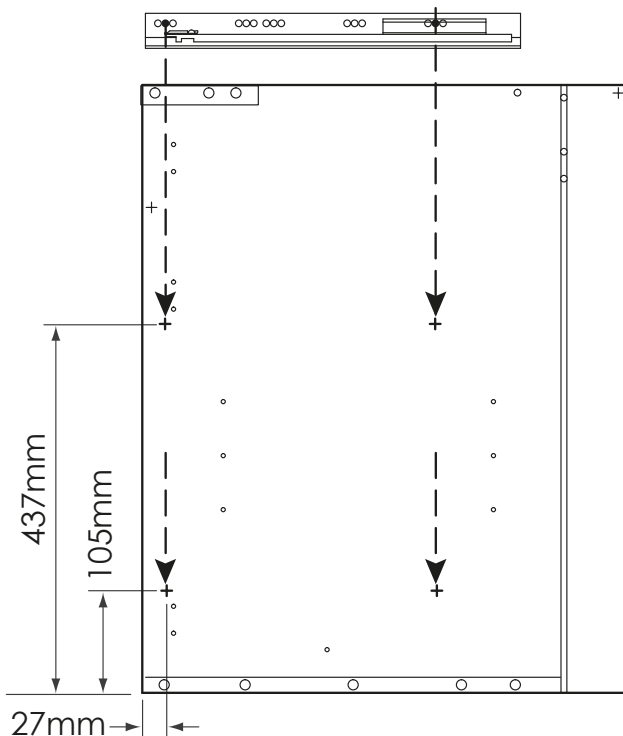

## 6. Installation - Modifications for a combination hob hood >600mm cabinet

### ① Remove the back panel

Keep the back panel for later use.

⚠ Set up for standard or handleless kitchens is the same.

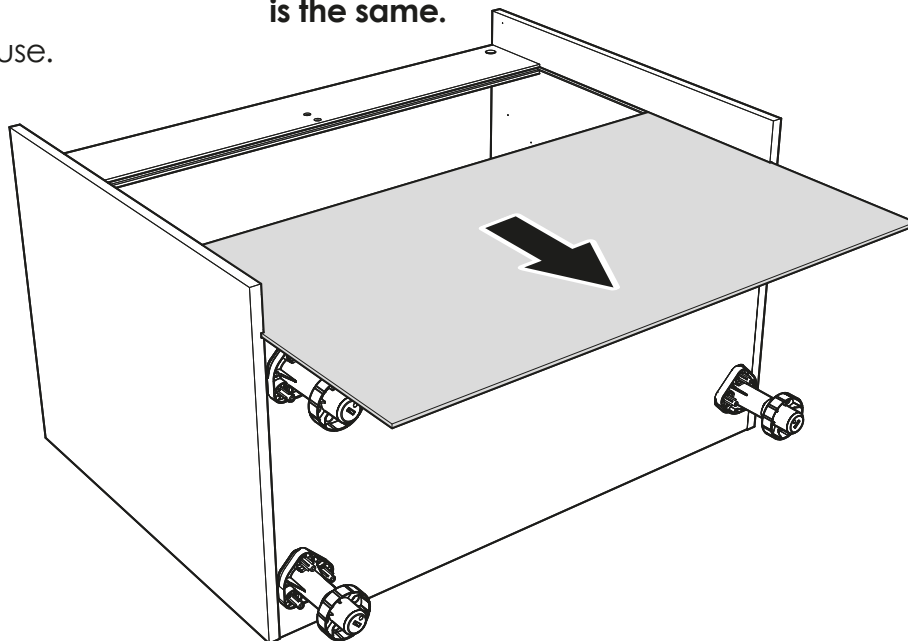

For illustrative purposes the frontal option has been shown.

Variations for the drawer option are detailed separately.

**Read all stages before modifying the cabinet.**

### ② Modify base

Cut out a section in the bottom shelf for ducting (to suit position of hob and ducting).

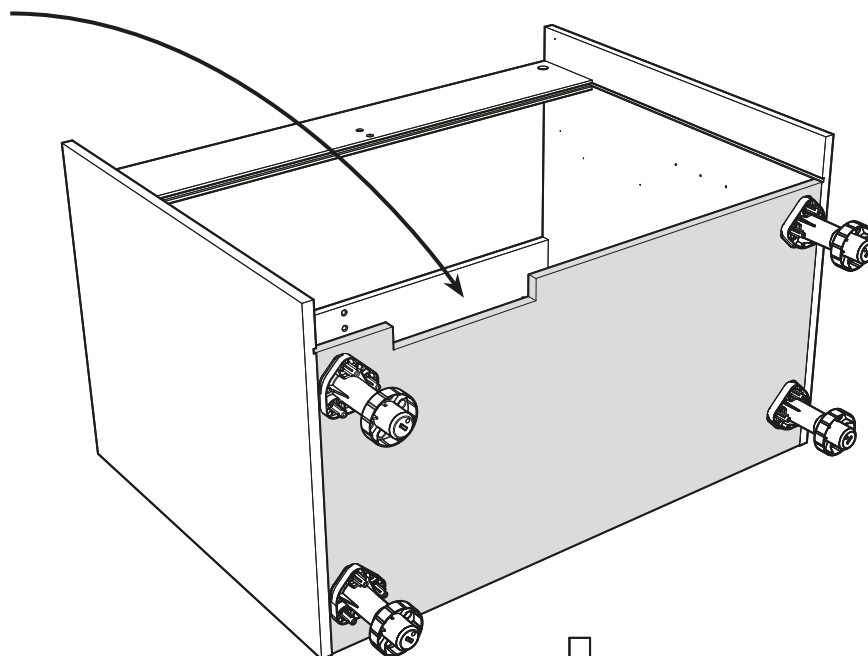

\*Dimensions are guides only.

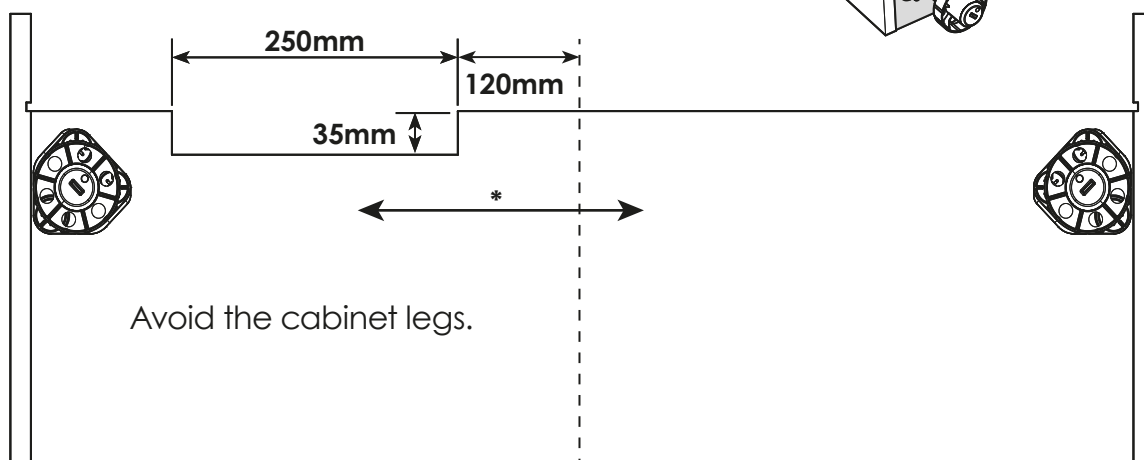

## 6. Installation - Modifications for a combination hob hood >600mm cabinet

### ③ Make front support panel

Remove front rail.

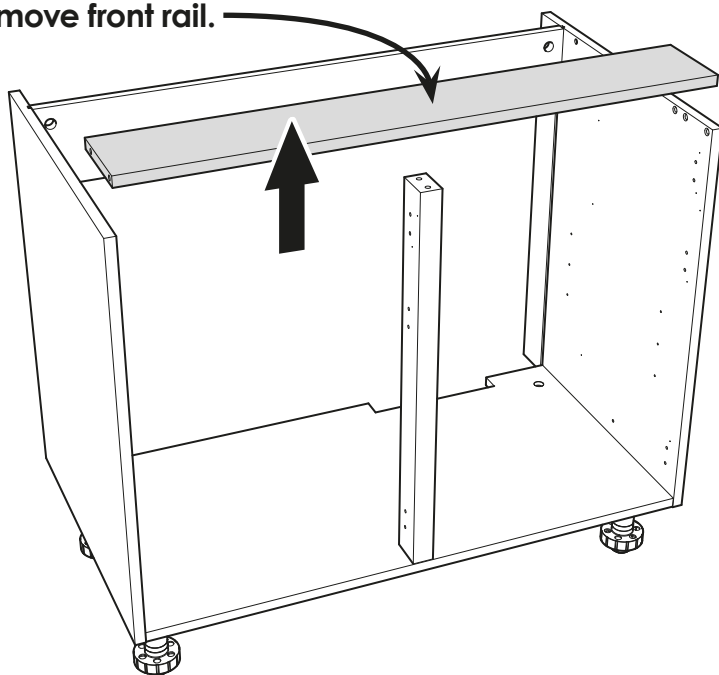

Remove c.122mm (140-18), the height of the support panel) from centre upright.

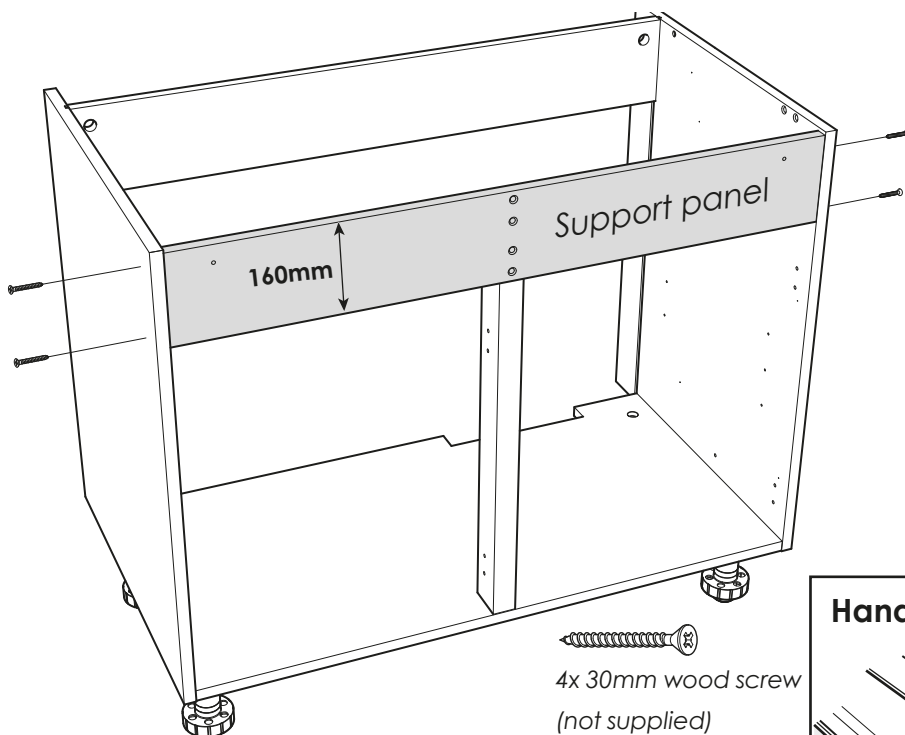
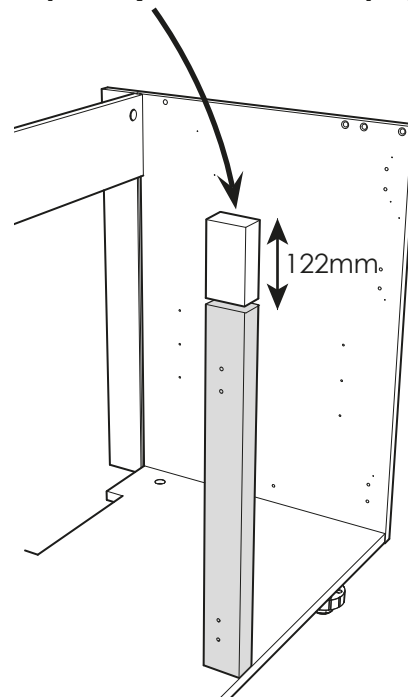

Fit support panel flush with the top of the cabinet.

Secure with KD blocks and side screws.

#### Handleless Kitchen (Profile)

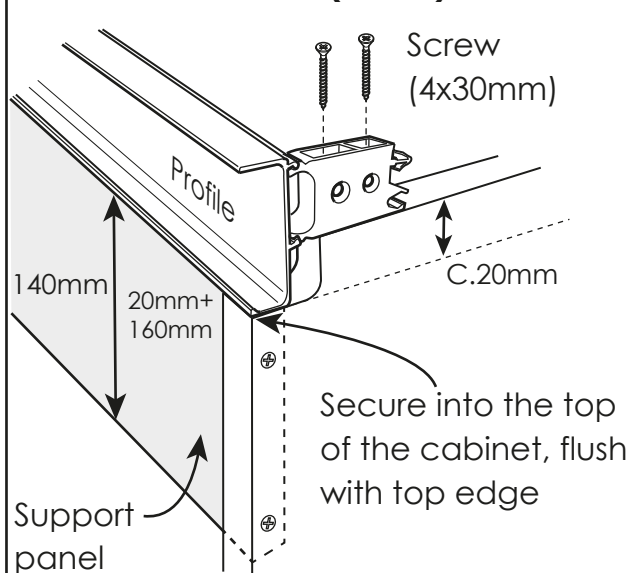

The support panel will be visible when complete, therefore we recommend using a decor panel of some sort.



## 6. Installation - Modifications for a combination hob hood >600mm cabinet

### ④ Remove and cut down back rail

⚠️ Avoid metal tangs on wider cabinets.

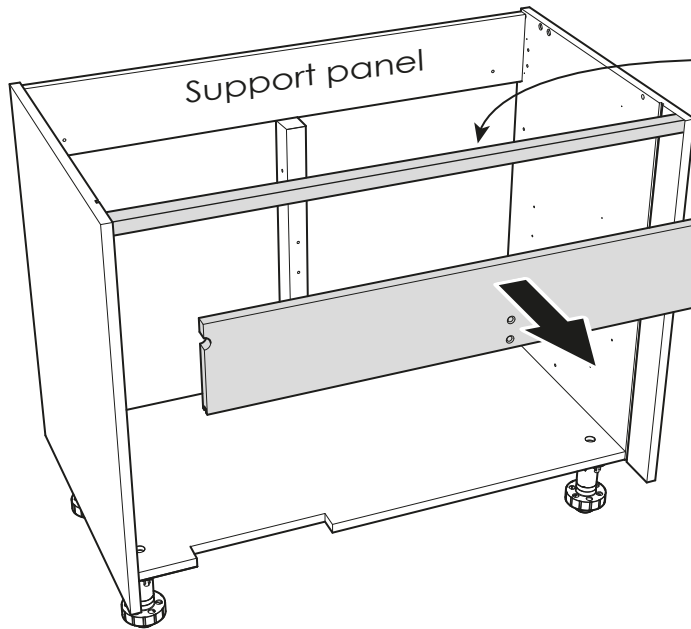

Insert batten at the back of the cabinet to support worktop.

Remove back rail and split into 3 long sections shown below.

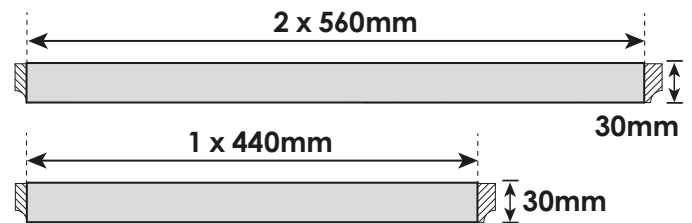

### ⑤ Fit back panel supports to cabinet sides

The cut down pieces of rail are used to hold the back panel in place.

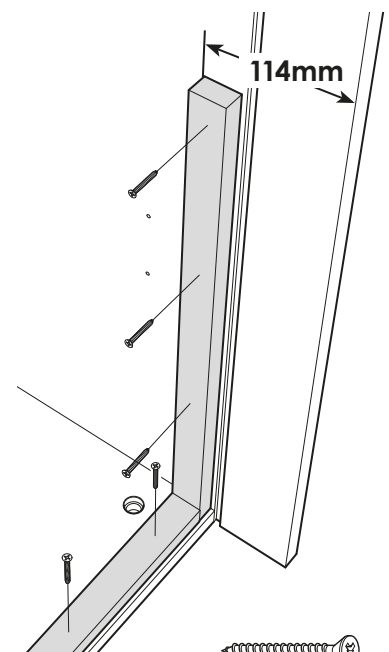
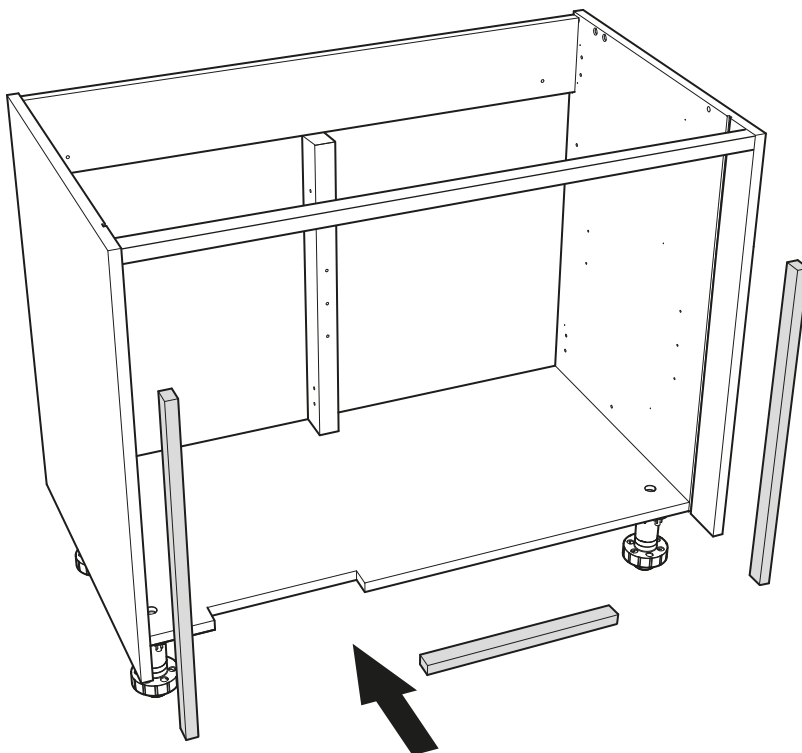

  
30mm Wood screw  
(not supplied)

⚠️ Don't cover the gap that has been cut for the ducting.

## 6. Installation - Modifications for a combination hob hood >600mm cabinet

### ⑥ Fit back panel

Cut down the back panel and screw to newly fitted support rails.

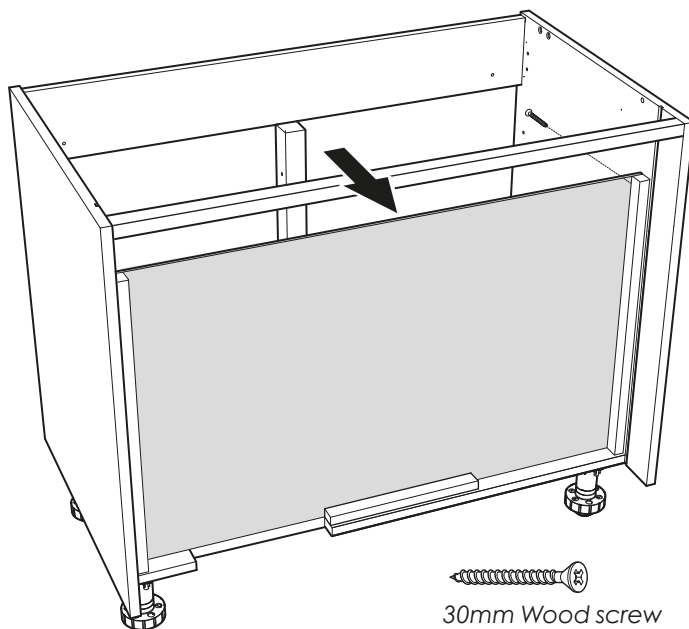
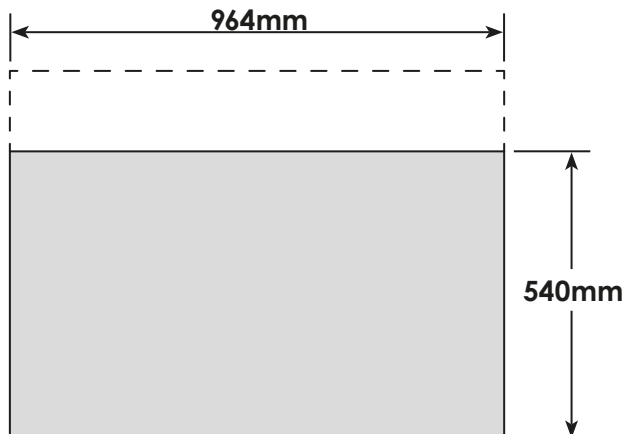

### Fitting with frontals

A new hinge hole will need to be drilled into the door at the dimensions shown below.

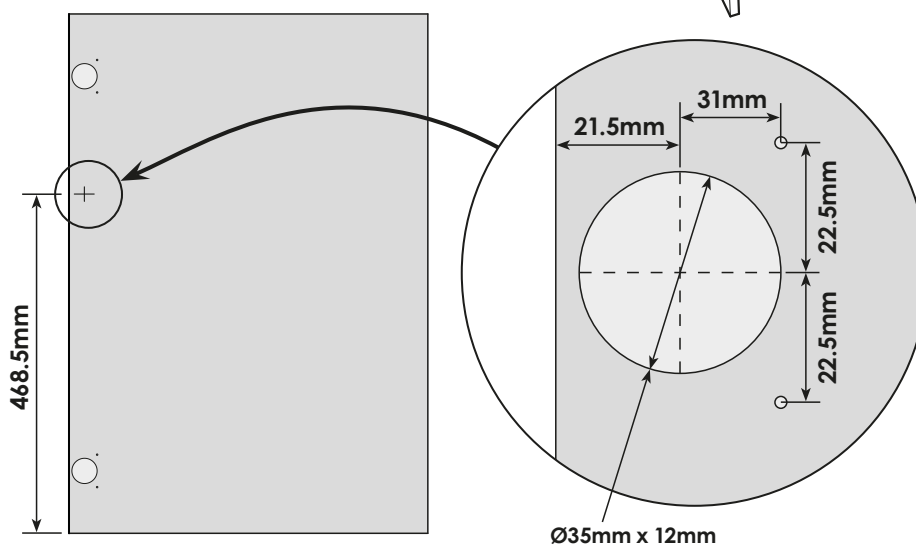
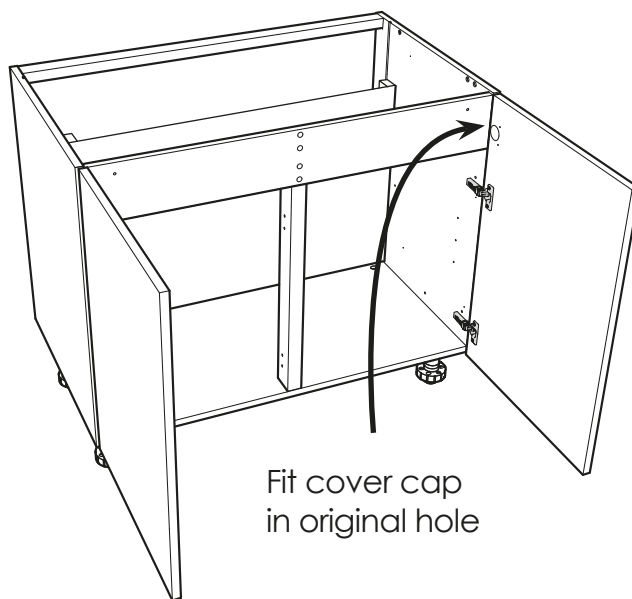
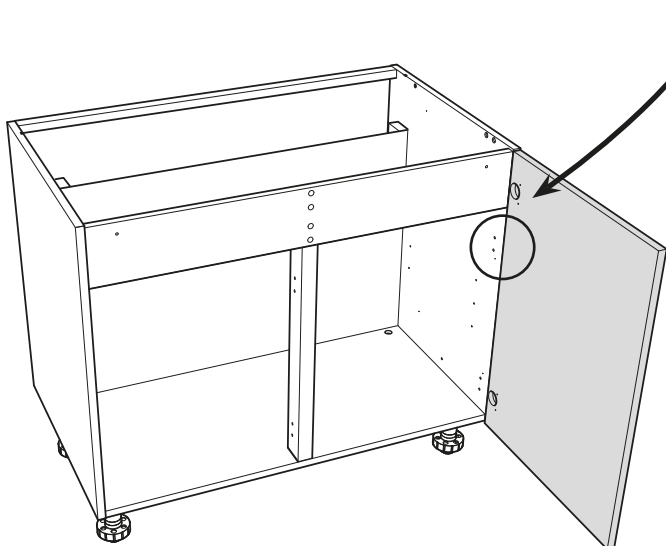

## 6. Modifications for a combination hob hood >600mm cabinet (drawers)

### Fitting with 3 drawers

⚠ Follow previous steps 1- 6, ignoring centre post modification.

Fix the dummy drawer frontal onto the support panel from inside the cabinet using suitable screws.

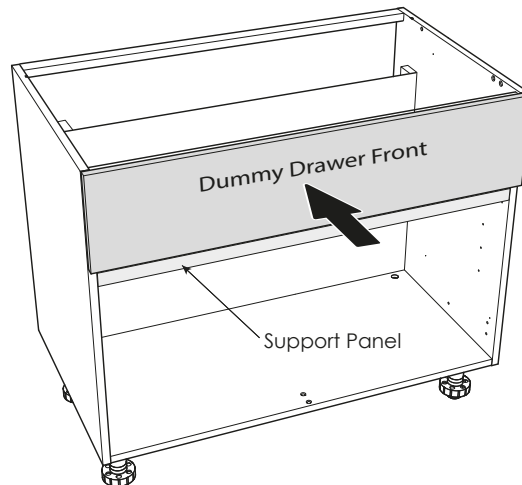

**Note:** Use bump-ons to maintain correct alignment.

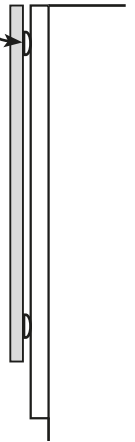

### Example drawer runner installation.

See Howdens Kitchen Installation Manual for drawer fixing and runner installation.

#### Standard

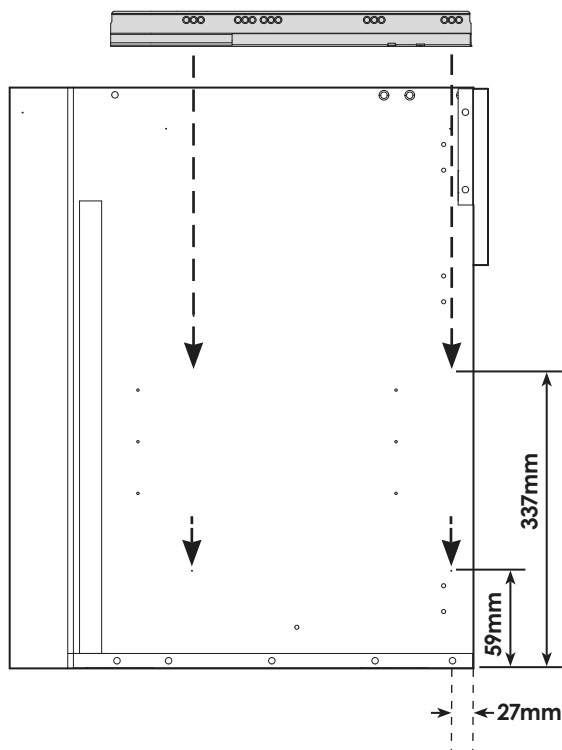
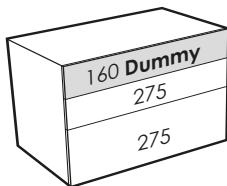

#### Handleless (Profile)

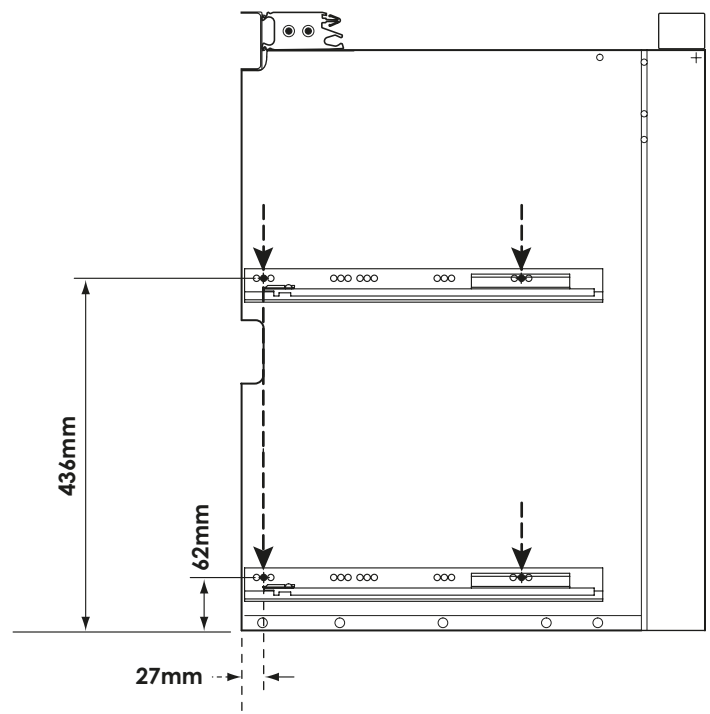
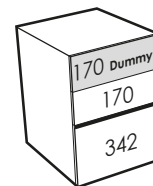

### **NOTE:**

**2 Drawer Option:** 2 x 356mm frontals (LAM9501).

- Top drawer must be a cutlery drawer box (max. weight 30Kg) due to lower rear wall.
- Lower drawer will be a pan drawer box.

See Howdens Kitchen Installation Manual for drawer fixing and runner installation.

## 6. Installation - Air extraction system assembly

### (A) Recirculation air

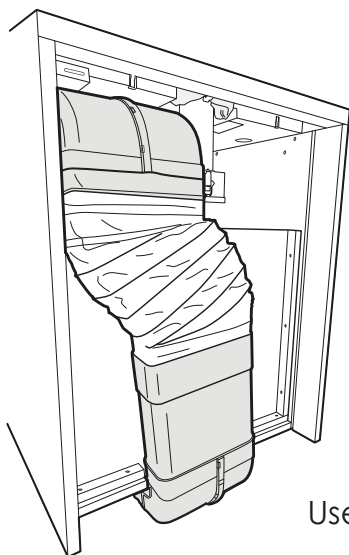

Use LAM2013 kit.

⚠ Ensure plinth vent is used.

### Side view cabinet (A)

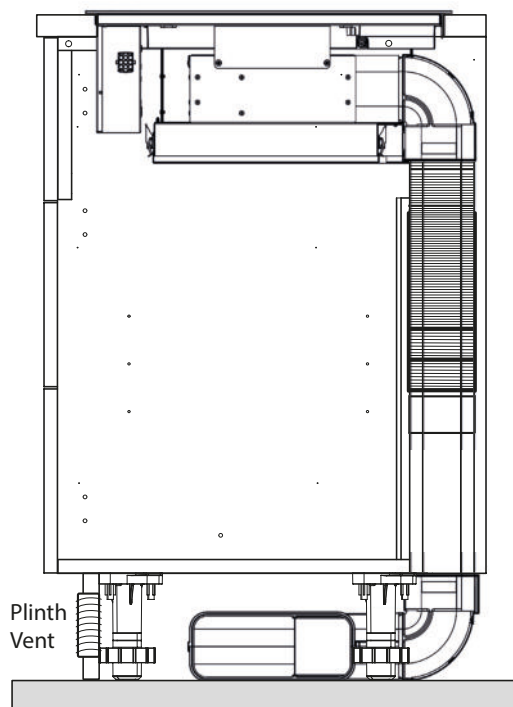

### External venting: Adapt to suit (B)



### (B) Extraction air

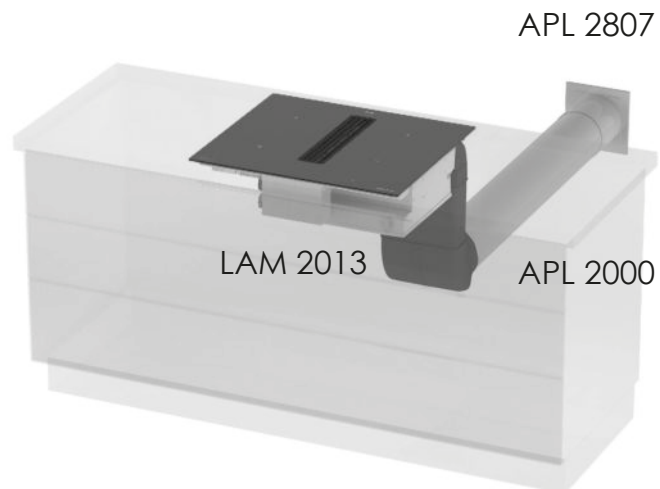

**Configure vent kits to suit application.**

Shown above using parts from LAM2013, APL2000 and APL2807

### Side view cabinet (B)

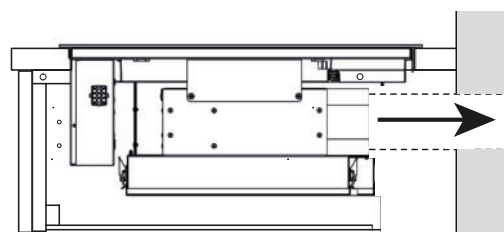
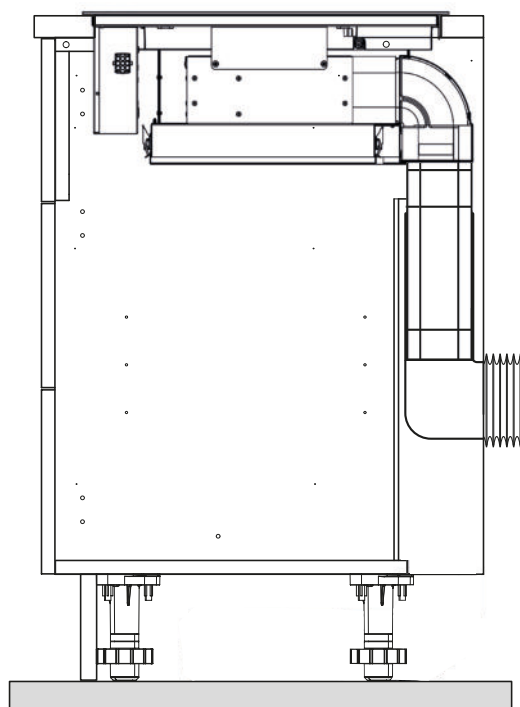

## 6. Installation *(continued)*

---

### Hob fan installation

---

- The product may only be connected by a qualified fitter according to applicable local regulations. The same applies for the extraction air connections. The fitter is responsible for proper functioning at the installation site.
- On installation, observe the relevant national building regulations and the regulations of the electricity suppliers.
- The hob fan can be operated in the extraction air and recirculation air mode.
- Lead the outgoing air outside through a ventilation shaft intended for this purpose or through the wall of the building.
- Outgoing air may not be led into a smoke or exhaust gas flue which is in operation. Contact the district master chimney sweep if you are in any doubt.
- A sufficient supply of inlet air must be provided if a wood, coal, gas or oil heater requiring a chimney is operated in the environment of the hob fan, since an insufficient supply of air results in a risk of poisoning. The safe operation of the hob extractor is guaranteed when the negative pressure resulting from the hob extractor does not exceed 0.04 mbar (4 Pa) and a sufficient supply of inlet air can flow into the room.
- Exhaust air pipes must comply with fire class B 1 DIN 4102.
- Please make sure that the minimum nominal width of the appliance connecting pieces is not reduced.
- A system recommended for the airflow and compatible with the hob extractor should always be used.
- The nominal width of the recirculation air pipe should not be less than 150 mm.
- Exhaust air pipes should be as short as possible. They should not have a 90-degree angle; instead they should have soft bends and no reductions in their cross-section.
- Never use pipes with a diameter of less than 150 mm. No bends/angles may be laid 50 cm before the fan module.
- Always insert a straight piece of approx. 50 cm between two angles/bends.
- The cross-section of wall vents and the cut-out in the base panel should at least correspond to the exhaust air pipe. The outflow opening must be at least 500 cm<sup>2</sup>. Reduce the height of the skirting boards or make corresponding openings.
- When installing the appliance make sure that the convection air unit is still accessible when the kitchen has been completely installed.
- If necessary levelling feet for the kitchen units must be moved.



When the convection air mode is in operation, ventilation must be sufficient in order for the air humidity to be removed.

## 6. Installation *(continued)*

### Electrical connection



#### **WARNING OF ELECTRICAL ENERGY! RISK OF FATAL INJURY!**

Live components have been installed near this symbol. Covers bearing this sign may only be removed by a certified skilled electrician.

- The electrical connection must be carried out by a qualified electrician who is authorised to carry out such work!
- Statutory regulations and the connection specifications issued by the local power supply company must be strictly observed.
- When connecting the appliance it must be ensured that there is a device which makes it possible to universally disconnect it from the mains with a contact opening width of at least 3mm. Line-protecting switches, fuses or contactors are suitable cut-out devices. When connecting and repairing the appliance disconnect it from the electricity supply with one of these devices.
- The earth wire must be sufficiently long so that if the strain relief fails, the live wires of the connecting cable are subjected to tension before the earth wire.
- Any superfluous cable must be removed from the installation area beneath the appliance.
- Make sure that the local mains voltage is the same as the voltage on the rating label.
- Full protection against accidental contact must be ensured on installation.
- Attention: Incorrect connection may result in the power electronics unit being destroyed.
- The appliance is only authorised for permanent connection. It may not be connected with a shock-proof plug.

### Power supply

Mains voltage: 380-415V 3N~, 50/60Hz

230-240V 1N~, 50/60Hz

Component rated voltage: 220-240V

### Electrical connections: 6-pole connection

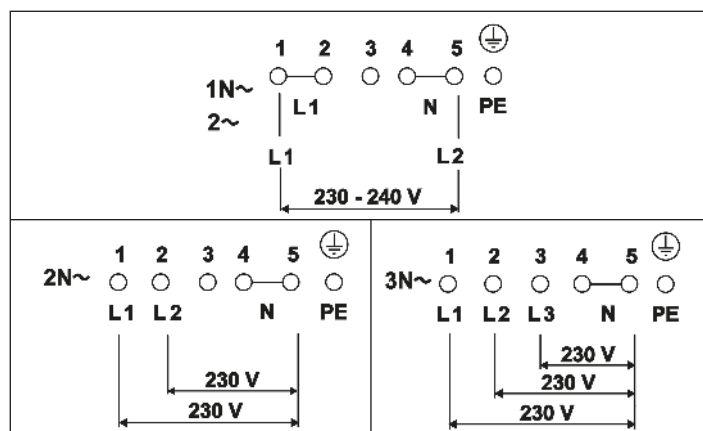

### Mains cable

- The hob has been fitted with a temperature-resistant connection cable.
- Connection to the mains is carried out in accordance with the circuit diagram, unless the connection cable is already fitted with a plug.
- If the mains cable of this appliance is damaged it will need to be replaced with a special connection cable. In order to avoid any risks, this must be carried out by the manufacturer or his Customer Service.

### Electrical connections

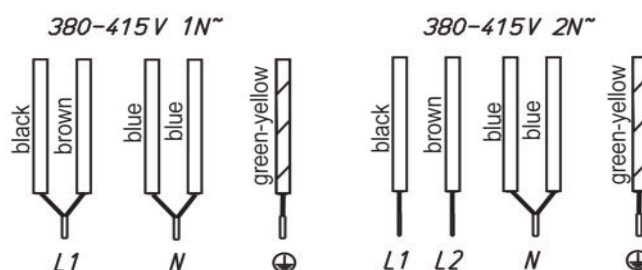

## 6. Installation *(continued)*

### Initial switching ON of the hob

Once the hob has been installed and the power supply has been provided (mains connected) an automatic test of the controls will be carried out and information for Customer Service will be indicated.

**Important:** No items may be on the touch control sensor keys when the appliance is being connected!

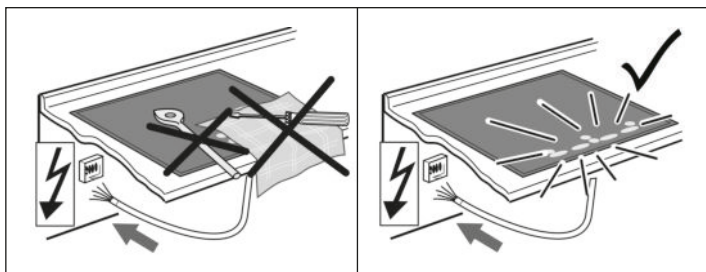

Briefly wipe over the surface of the hob with a sponge and soapy water and then dry with a clean cloth.

## 7. Technical specifications

<b>Hob dimensions</b>		
height/ width/ depth	mm	212 x 600 x 520
<b>Cooking zones</b>		
2x Induction cooking zone	cm / kW	19x21/ 2.1/ 3.0*
2x Induction cooking zone	cm / kW	19x21/ 2.1/ 3.0*
Bridging function	kW	3.7
<b>Fan</b>		
Max. air stream	m3/h	610
<b>Power supply</b>		
Hob	kW	7.2
Fan	kW	0.168

\* Power when the power boost function is activated

---

## 8 - Guarantee

### Product Guarantee Details (UK & Republic of Ireland only)

---

Your appliance has the benefit of a comprehensive manufacturer's guarantee which covers the cost of breakdown repairs. (Details of which are shown on your Proof of Purchase Document).

- Any claim during the period of the guarantee **MUST BE ACCOMPANIED BY THE PROOF OF PURCHASE.**
- The product must be correctly installed and operated in accordance with the manufacturer's instructions and used for normal domestic purposes.
- This guarantee does not cover accidental damage, misuse or alterations which are likely to affect the product.
- The guarantee is invalid if the product is tampered with, or repaired by any unauthorised person.  
(The guarantee in no way affects your statutory or legal rights).

### What to do if you need to report a problem.

Please ensure you have ready:

- The product's model and serial numbers.
- Howdens Proof of Purchase Document.
- Your full contact details.

**Call the Depot number on your Proof of Purchase Document supplied with the product/kitchen.**

or

**Call the LAMONA Service Line on:**

**Within UK 0344 460 0006**

**Within Republic of Ireland 01525 5703**

\* Product installed within a domestic kitchen or a non-domestic kitchen where 8 or fewer people are using the appliance.

**Spare parts availability - 10 years**

**Only fit Genuine Spare Parts**

**[www.lamonaspares.co.uk](http://www.lamonaspares.co.uk)** (UK only)

Where to find the model and serial number on the appliance.	On the body of the hob hood.
---	------------------------------











Product serial number  
(Place sticker here)

# LAMONA

at the heart of the kitchen



Howden Joinery Ltd. Thorpe Road, Howden, East Yorkshire. DN14 7PA

Imported in EU by: Howdens Cuisines SAS. Z.A. du Bois Rigault Nord,  
1 Rue Calmette, 62880 Vendin-le-Vieil, Cedex, France

Product information correct at the time of publication in January 2022.

The company has a policy of continuous product development and reserves the right to change any products and specifications given in this manual. Subject to the Terms and Conditions of Trading, a copy of the Howdens Terms and Conditions is available upon request.

Copyright © 2022 Howden Joinery Ltd. All rights reserved.