

# USER MANUAL

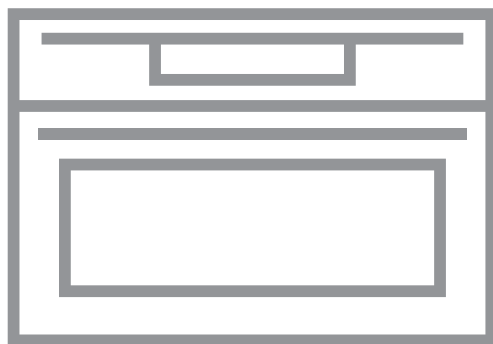

# FOR PERFECT RESULTS

---

Thank you for choosing this AEG product. We have created it to give you impeccable performance for many years, with innovative technologies that help make life simpler – features you might not find on ordinary appliances. Please spend a few minutes reading to get the very best from it.

Visit our website to:



Get usage advice, brochures, trouble shooter, service and repair information:  
**[www.aeg.com/support](http://www.aeg.com/support)**



Register your product for better service:  
**[www.registeraeg.com](http://www.registeraeg.com)**



Buy Accessories, Consumables and Original spare parts for your appliance:  
**[www.aeg.com/shop](http://www.aeg.com/shop)**

## CUSTOMER CARE AND SERVICE

---

Always use original spare parts.

When contacting our Authorised Service Centre, ensure that you have the following data available: Model, PNC, Serial Number.

The information can be found on the rating plate.

Warning / Caution-Safety information

General information and tips

Environmental information

## CONTENTS

---

<b>1. SAFETY INFORMATION.....</b>	<b>3</b>	<b>5. BEFORE FIRST USE.....</b>	<b>12</b>
1.1 Children and vulnerable people safety.....	3	5.1 Initial cleaning.....	12
1.2 General Safety.....	4	<b>6. DAILY USE.....</b>	<b>12</b>
<b>2. SAFETY INSTRUCTIONS.....</b>	<b>6</b>	6.1 How to set: Heating functions.....	12
2.1 Installation.....	6	6.2 How to set: Microwave heating functions.....	12
2.2 Electrical connection.....	7	6.3 Heating functions.....	13
2.3 Use.....	8	6.4 How to set: Assisted Cooking.....	14
2.4 Care and cleaning.....	8	6.5 Assisted Cooking.....	15
2.5 Glassware use.....	9	<b>7. CLOCK FUNCTIONS.....</b>	<b>20</b>
2.6 Internal lighting.....	9	7.1 Clock functions.....	20
2.7 Service.....	9	7.2 How to set: Clock functions.....	21
2.8 Disposal.....	9	<b>8. HOW TO USE: ACCESSORIES.....</b>	<b>22</b>
<b>3. PRODUCT DESCRIPTION.....</b>	<b>10</b>	8.1 Inserting accessories.....	22
3.1 General overview.....	10	<b>9. ADDITIONAL FUNCTIONS.....</b>	<b>23</b>
3.2 Accessories.....	10	9.1 Lock.....	23
<b>4. HOW TO TURN OVEN ON AND OFF.....</b>	<b>11</b>	9.2 Automatic switch-off.....	23
4.1 Retractable knobs.....	11	9.3 Cooling fan.....	24
4.2 Control panel.....	11		

<b>10. HINTS AND TIPS.....</b>	<b>24</b>	<b>12. TROUBLESHOOTING.....</b>	<b>28</b>
<b>10.1</b> Microwave recommendations .....	24	<b>12.1</b> What to do if.....	28
<b>10.2</b> Microwave suitable cookware and materials .....	25	<b>12.2</b> Service data.....	29
<b>10.3</b> Recommended power settings for different kinds of food.....	25	<b>13. ENERGY EFFICIENCY.....</b>	<b>30</b>
<b>10.4</b> Cooking tables for test institutes..	25	<b>13.1</b> Energy saving.....	30
<b>11. CARE AND CLEANING.....</b>	<b>27</b>	<b>14. MENU STRUCTURE.....</b>	<b>30</b>
<b>11.1</b> Notes on cleaning.....	27	<b>14.1</b> Menu.....	30
<b>11.2</b> How to remove: Shelf supports ...	27	<b>15. ENVIRONMENTAL CONCERNS.....</b>	<b>31</b>
<b>11.3</b> How to replace: Lamp.....	28		

Subject to change without notice.

## **1. SAFETY INFORMATION**

---

Before the installation and use of the appliance, carefully read the supplied instructions. The manufacturer is not responsible for any injuries or damage that are the result of incorrect installation or usage. Always keep the instructions in a safe and accessible location for future reference.

### **1.1 Children and vulnerable people safety**

- This appliance can be used by children aged from 8 years and above and persons with reduced physical, sensory or mental capabilities or lack of experience and knowledge if they have been given supervision or instruction concerning the use of the appliance in a safe way and understand the hazards involved. Children of less than 8 years of age and persons with very extensive and complex disabilities shall be kept away from the appliance unless continuously supervised.
- Children should be supervised to ensure that they do not play with the appliance.
- Keep all packaging away from children and dispose of it appropriately.

# SAFETY INFORMATION

---

- **WARNING:** The appliance and its accessible parts become hot during use. Keep children and pets away from the appliance when in use and when cooling down.
- If the appliance has a child safety device, it should be activated.
- Children shall not carry out cleaning and user maintenance of the appliance without supervision.

## 1.2 General Safety

- This appliance is for cooking purposes only.
- This appliance is designed for single household domestic use in an indoor environment.
- This appliance may be used in, offices, hotel guest rooms, bed & breakfast guest rooms, farm guest houses and other similar accommodation where such use does not exceed (average) domestic usage levels.
- Only a qualified person must install this appliance and replace the cable.
- Do not use the appliance before installing it in the built-in structure.
- Disconnect the appliance from the power supply before carrying out any maintenance.
- If the mains power supply cable is damaged, it must be replaced by the manufacturer, its Authorised Service Centre or similarly qualified persons to avoid an electrical hazard.
- **WARNING:** Ensure that the appliance is switched off before replacing the lamp to avoid the possibility of electric shock.
- **WARNING:** The appliance and its accessible parts become hot during use. Care should be taken to avoid touching heating elements.
- Always use oven gloves to remove or insert accessories or ovenware.

- Do not activate the microwave function when the appliance is empty. Metal parts inside the cavity can create electric arcing.
- Metallic containers for food and beverages are not allowed during microwave cooking. This requirement is not applicable if the manufacturer specifies size and shape of metallic containers suitable for microwave cooking.
- **WARNING:** If the door or door seals are damaged, the appliance must not be operated until it has been repaired by a qualified person.
- **WARNING:** Only a qualified person can carry out any service or repair operation that involves the removal of a cover which gives protection against exposure to microwave energy.
- **WARNING:** Do not heat liquids and other foods in sealed containers. They are liable to explode.
- Use only utensils that are suitable for use in microwave ovens.
- When heating food in plastic or paper containers, observe the appliance due to the possibility of ignition.
- The appliance is intended for heating food and beverages. Drying of food or clothing and heating of warming pads, slippers, sponges, damp cloth and similar may lead to risk of injury, ignition or fire.
- If smoke is emitted, switch off or unplug the appliance and keep the door closed in order to stifle any flames.
- Microwave heating of beverages can result in delayed eruptive boiling. Care must be taken when handling the container.
- The contents of feeding bottles and baby food jars shall be stirred or shaken and the temperature checked before consumption, in order to avoid burns.
- Eggs in their shell and whole hard-boiled eggs should not be heated in the appliance since they may explode, even after microwave heating has ended.

# SAFETY INSTRUCTIONS

---

- To remove the shelf supports first pull the front of the shelf support and then the rear end away from the side walls. Install the shelf supports in the opposite sequence.
- The appliance should be cleaned regularly and any food deposits removed.
- Do not use a steam cleaner to clean the appliance.
- Do not use harsh abrasive cleaners or sharp metal scrapers to clean the glass door since they can scratch the surface, which may result in shattering of the glass.
- Failure to maintain the appliance in a clean condition could lead to deterioration of the surface that could adversely affect the life of the appliance and possibly result in a hazardous situation.

## 2. SAFETY INSTRUCTIONS

---

### 2.1 Installation

**WARNING!**

Only a qualified person must install this appliance.

- Remove all the packaging.
- Do not install or use a damaged appliance.
- Follow the installation instructions supplied with the appliance.
- Always take care when moving the appliance as it is heavy. Always use safety gloves and enclosed footwear.
- Do not pull the appliance by the handle.
- Install the appliance in a safe and suitable place that meets installation requirements.
- Keep the minimum distance from other appliances and units.
- Before mounting the appliance, check if the oven door opens without restraint.
- The appliance is equipped with an electric cooling system. It must be operated with the electric power supply.
- The built-in unit must meet the stability requirements of DIN 68930.

Cabinet minimum height (Cabinet under the work-top minimum height)	444 (460) mm
Cabinet width	560 mm
Cabinet depth	550 (550) mm
Height of the front of the appliance	455 mm

Height of the back of the appliance	440 mm
Width of the front of the appliance	595 mm
Width of the back of the appliance	559 mm
Depth of the appliance	567 mm
Built in depth of the appliance	546 mm
Depth with open door	882 mm
Ventilation opening minimum size. Opening placed on the bottom rear side	560x20 mm
Mains supply cable length. Cable is placed in the right corner of the back side	1500 mm
Mounting screws	3.5x25 mm

## 2.2 Electrical connection



### **WARNING!**

Risk of fire and electric shock.

- All electrical connections should be made by a qualified electrician.
- The appliance must be earthed.
- Make sure that the parameters on the rating plate are compatible with the electrical ratings of the mains power supply.
- Always use a correctly installed shockproof socket.
- Do not use multi-plug adapters and extension cables.
- Make sure not to cause damage to the mains plug and to the mains cable. Should the mains cable need to be replaced, this must be carried out by our Authorised Service Centre.
- Do not let mains cables touch or come near the appliance door or the niche below the appliance, especially when it operates or the door is hot.
- The shock protection of live and insulated parts must be fastened in such a way that it cannot be removed without tools.
- Connect the mains plug to the mains socket only at the end of the installation. Make sure that there is access to the mains plug after the installation.
- If the mains socket is loose, do not connect the mains plug.
- Do not pull the mains cable to disconnect the appliance. Always pull the mains plug.
- Use only correct isolation devices: line protecting cut-outs, fuses (screw type fuses removed from the holder), earth leakage trips and contactors.
- The electrical installation must have an isolation device which lets you disconnect the appliance from the mains at all poles. The isolation device must have a contact opening width of minimum 3 mm.
- This appliance is supplied only with a main cable.

# SAFETY INSTRUCTIONS

---

## 2.3 Use

**WARNING!**

Risk of injury, burns and electric shock or explosion.

- Do not change the specification of this appliance.
- Make sure that the ventilation openings are not blocked.
- Do not let the appliance stay unattended during operation.
- Deactivate the appliance after each use.
- Be careful when you open the appliance door while the appliance is in operation. Hot air can release.
- Do not operate the appliance with wet hands or when it has contact with water.
- Do not apply pressure on the open door.
- Do not use the appliance as a work surface or as a storage surface.
- Open the appliance door carefully. The use of ingredients with alcohol can cause a mixture of alcohol and air.
- Do not let sparks or open flames to come in contact with the appliance when you open the door.
- Do not put flammable products or items that are wet with flammable products in, near or on the appliance.
- Do not use microwave function to preheat the oven.

**WARNING!**

Risk of damage to the appliance.

- To prevent damage or discoloration to the enamel:
  - do not put aluminium foil directly on the bottom of cavity of the appliance.
  - do not put water directly into the hot appliance.
  - do not keep moist dishes and food in the appliance after you finish the cooking.
  - be careful when you remove or install the accessories.
- Discoloration of the enamel or stainless steel has no effect on the performance of the appliance.
- Use a deep pan for moist cakes. Fruit juices cause stains that can be permanent.
- Always cook with the appliance door closed.
- If the appliance is installed behind a furniture panel (e.g. a door) make sure the door is never closed when the appliance operates. Heat and moisture can build up behind a closed furniture panel and cause subsequent damage to the appliance, the housing unit or the floor. Do not close the furniture panel until the appliance has cooled down completely after use.

## 2.4 Care and cleaning

**WARNING!**

Risk of injury, fire, or damage to the appliance.

- Before maintenance, deactivate the appliance and disconnect the mains plug from the mains socket.
- Make sure the appliance is cold. There is the risk that the glass panels can break.
- Replace immediately the door glass panels when they are damaged. Contact the Authorised Service Centre.
- Be careful when you remove the door from the appliance. The door is heavy!



- Make sure the cavity and the door are wiped dry after each use. Steam produced during the operation of the appliance condensates on cavity walls and can cause corrosion.
- Clean regularly the appliance to prevent the deterioration of the surface material.
- Fat and food remaining in the appliance can cause fire and electric arcing when the microwave function operates.
- Clean the appliance with a moist soft cloth. Use only neutral detergents. Do not use abrasive products, abrasive cleaning pads, solvents or metal objects.
- If you use an oven spray, follow the safety instructions on its packaging.

## 2.5 Glassware use

Handling your glassware without an appropriate degree of care could result in breakage, chipping, cracking or severe scratching:

- Do not spill cold water or other liquids on the glassware because a sudden temperature drop may cause immediate breakage of the glass. Broken glass pieces may be extremely sharp and difficult to locate.
- Do not place hot glassware on a wet or cool surface, directly on countertop or metal surface, or in sink; or handle hot glassware with wet cloth.
- Do not use or repair any glassware that is chipped, cracked or severely scratched.
- Do not drop or hit glassware against a hard object or strike utensils against it.
- Do not heat empty or nearly empty glassware in microwave, or overheat oil or butter in microwave (use minimum amount of cooking time).

Allow hot glassware to cool on a cooling rack, a potholder or a dry cloth. Make sure that the glassware is cool enough before washing, refrigerating or freezing.

Avoid handling hot glassware (including ware with silicone gripping surfaces) without dry potholders.

Avoid microwave misuse (i.e. running the oven without any load or small load).

## 2.6 Internal lighting



### **WARNING!**

Risk of electric shock.

- Concerning the lamp(s) inside this product and spare part lamps sold separately: These lamps are intended to withstand extreme physical conditions in household appliances, such as temperature, vibration, humidity, or are intended to signal information about the operational status of the appliance. They are not intended to be used in other applications and are not suitable for household room illumination.
- This product contains a light source of energy efficiency class G.
- Use only lamps with the same specifications.

## 2.7 Service

- To repair the appliance contact the Authorised Service Centre.
- Use original spare parts only.

## 2.8 Disposal



### **WARNING!**

Risk of injury or suffocation.

- Contact your municipal authority for information on how to dispose of the appliance.
- Disconnect the appliance from the mains supply.

# PRODUCT DESCRIPTION

---

- Cut off the mains electrical cable close to the appliance and dispose of it.
- Remove the door catch to prevent children or pets from becoming trapped in the appliance.

## 3. PRODUCT DESCRIPTION

---

### 3.1 General overview

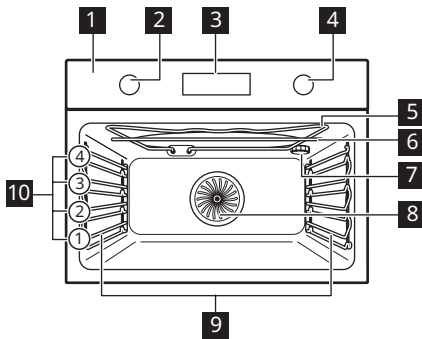

- 1 Control panel
- 2 Knob for the heating functions
- 3 Display
- 4 Control knob
- 5 Heating element
- 6 Microwave generator
- 7 Lamp
- 8 Fan
- 9 Shelf support, removable
- 10 Shelf positions

### 3.2 Accessories

#### Wire shelf

For cookware, cake tins, roasts.

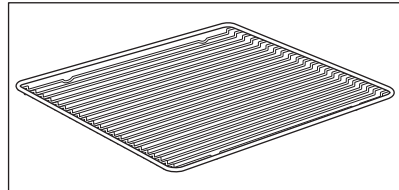

#### Baking tray

For cakes and biscuits.

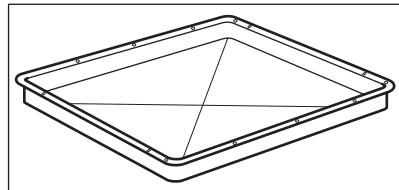

#### Microwave bottom glass plate

To prepare food in microwave mode.

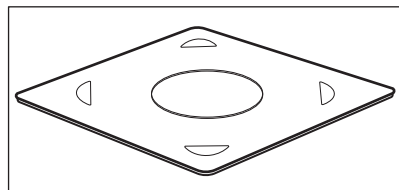







## 4. HOW TO TURN OVEN ON AND OFF







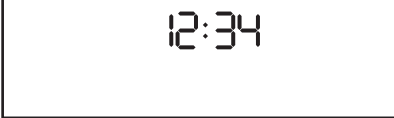

### 4.1 Retractable knobs

To use the appliance press the knob. The knob comes out.

### 4.2 Control panel

Control panel sensor fields					Press	Turn the knob
			WATT	OK		
Timer	Fast Heat Up	Light	Microwave power	Confirm setting		
Select a heating function to turn on the oven.						
Turn the knob for the heating functions to the off position to turn the oven off.						

	When the knob for the heating functions is in the off position, the display goes to standby.
	Display with key functions.

<b>Display indicators:</b>	 Lock	 Assisted Cooking	 Settings	 Microwave function indicator
<b>Timer indicators:</b>		 STOP		

<b>Progress bar</b> - for temperature or time. The bar is fully red when the oven reaches the set temperature.	
--	---

# BEFORE FIRST USE

## 5. BEFORE FIRST USE



### WARNING!

Refer to Safety chapters.

### 5.1 Initial cleaning

Before the first use clean the empty oven and set the time:



00:00

Set the time. Press **OK**.

## 6. DAILY USE



### WARNING!

Refer to Safety chapters.

### 6.1 How to set: Heating functions

Start cooking

#### Step 1



Select a heating function.

#### Step 2



Set the temperature.  
Press **WATT** and turn the control knob to adjust microwave power.  
Press **OK**.

### 6.2 How to set: Microwave heating functions

#### Step 1

Remove all accessories.  
Insert microwave bottom glass plate. Put the food on the microwave bottom glass plate.

<b>Step 2</b>	Select a microwave heating function and press: <b>OK</b> to start with default settings. The display shows: duration and microwave power.
<b>Step 3</b>	Turn the knob for the heating functions to the off position to turn off the oven.
<p>You can adjust settings while cooking.</p> <p>Turn the control knob to adjust duration. Press: <b>OK</b></p> <p>Press <b>WATT</b> and turn the control knob to adjust microwave power. Press: <b>OK</b></p>	

The maximum time of microwave functions depends on microwave power you set:



MICROWAVE POWER	MAXIMUM TIME
100 - 600 W	59:55 minutes
More than 600 W	7 minutes









If you open the door, the microwave function stops. To start it again, close the door. Press **OK**.

## 6.3 Heating functions

### Standard heating functions

Heating function	Application
 <b>True Fan Cooking</b>	To bake on up to two shelf positions at the same time and to dry food. Set the temperature 20 - 40 °C lower than for Conventional Cooking.
 <b>Conventional Cooking</b>	To bake and roast food on one shelf position.
 <b>Turbo Grilling</b>	To roast large meat joints or poultry with bones on one shelf position. To make gratins and to brown.





Heating function	Application
 <p><b>Pizza Function</b></p>	To bake pizza. To make intensive browning and a crispy bottom.
 <p><b>Turbo Grilling + MW</b></p>	To roast large pieces of meat on one level. To make gratins and to brown. The function with MW boost.
 <p><b>True Fan Cooking + MW</b></p>	Baking on one shelf position. The function with MW boost.
 <p><b>Defrost</b></p>	Defrosting meat, fish, cakes, power range: 100 - 200 W
 <p><b>Reheat</b></p>	Heating up pre-prepared meals and delicate food, power range: 300 - 700 W
 <p><b>Microwave</b></p>	Heating up, cooking, power range: 100 - 1000 W
 <p><b>Menu</b></p>	To enter the Menu: Assisted Cooking, Cleaning, Settings.

## 6.4 How to set: Assisted Cooking





The Assisted Cooking submenu consists of a set of additional functions and dishes with recommended cooking functions, temperatures and times. You can adjust the time and the temperature during cooking.

For some of the dishes you can also cook with:	<ul style="list-style-type: none"> <li>• Weight Automatic</li> </ul>
--	--

Assisted Cooking - use it to prepare a dish quickly with default settings:			
<b>Step 1</b>	<b>Step 2</b>	<b>Step 3</b>	<b>Step 4</b>

Assisted Cooking - use it to prepare a dish quickly with default settings:			
		 P1 - P45	 OK
Enter the menu.	Select Assisted Cooking. Press OK.	Select the dish. Press OK.	Insert the dish to the oven. Confirm setting.









## 6.5 Assisted Cooking

Legend	
	Weight Automatic available.
	Function with microwave power. Use microwave safe accessory.
	Preheat the oven before you start cooking.
	Shelf level.















	Heating function	Application
<b>F1</b>	Grill	To grill thin pieces of food and to toast bread.
<b>F2</b>	Bottom Heat	To bake cakes with crispy bottom and to preserve food.
<b>F3</b>	Frozen Foods	To make convenience food (e.g., french fries, potato wedges or spring rolls) crispy.
<b>F4</b>	Conventional Cooking + MW	Baking and roasting food on one shelf position. The function with MW boost.
<b>F5</b>	Grill + MW	To cook food in a short time and to brown it. The function with MW boost.

When the function ends check if the food is ready.



















# DAILY USE



















	Dish	Weight	Shelf level / Accessory	Duration time
<b>Beef</b> 				
<b>P1</b>	<b>Roast Beef, rare</b>	1 - 1,5 kg; 4 - 5 cm thick pieces	 <b>1; baking tray</b> Fry the meat for a few minutes on a hot pan. Insert to the oven.	40 min
<b>P2</b>	<b>Roast Beef, medium</b>			50 min
<b>P3</b>	<b>Roast Beef, well done</b>			60 min
<b>P4</b>	<b>Steak, medium</b>	180 - 220 g per piece; 3 cm thick slices	  <b>2; roasting dish on wire shelf</b> Fry the meat for a few minutes on a hot pan. Insert to the oven.	15 min
<b>P5</b>	<b>Beef roast / braised</b> (prime rib, top round, thick flank)	1,5 - 2 kg	  <b>1; roasting dish on wire shelf</b> Fry the meat for a few minutes on a hot pan. Add liquid. Insert to the oven.	120 min
<b>P6</b>	<b>Roast Beef, rare</b> (slow cooking)	1 - 1,5 kg; 4 - 5 cm thick pieces	 <b>1; baking tray</b> Use your favourite spices or simply salt and fresh ground pepper. Fry the meat for a few minutes on a hot pan. Insert to the oven.	75 min
<b>P7</b>	<b>Roast Beef, medium</b> (slow cooking)			85 min
<b>P8</b>	<b>Roast Beef, well done</b> (slow cooking)			130 min
<b>P9</b>	<b>Fillet, rare</b> (slow cooking)	0,5 - 1,5 kg; 5 - 6 cm thick pieces	 <b>1; baking tray</b> Use your favourite spices or simply salt and fresh ground pepper. Fry the meat for a few minutes on a hot pan. Insert to the oven.	75 min
<b>P10</b>	<b>Fillet, medium</b> (slow cooking)			90 min
<b>P11</b>	<b>Fillet, done</b> (slow cooking)			120 min
<b>Veal</b> 				













	Dish	Weight	Shelf level / Accessory	Duration time
P12	<b>Veal roast</b> (e.g. shoulder)	0,8 - 1,5 kg; 4 cm thick pieces	  <b>1</b> ; roasting dish on <b>wire shelf</b> Use your favourite spices. Add liquid. Roast covered.	80 min
<b>Pork</b>  				
P13	<b>Pork roast neck or shoulder</b>	1,5 kg	  <b>1</b> ; ceramic or glass casserole dish on <b>wire shelf</b> , MW suitable Use your favourite spices. Turn the meat after half of the cooking time.	90 min
P14	<b>Pulled pork</b> (slow cooking)	1,5 - 2 kg	 <b>1</b> ; <b>baking tray</b> Use your favourite spices. Turn the meat after half of the cooking time to get an even browning.	215 min
P15	<b>Loin, fresh</b>	1 - 1,5 kg; 5 - 6 cm thick pieces	 <b>1</b> ; roasting dish on <b>wire shelf</b> Use your favourite spices.	55 min
P16	<b>Spare Ribs</b>	2 - 3 kg; use raw, 2 - 3 cm thin spare ribs	 <b>2</b> ; <b>deep pan</b> Add liquid to cover the bottom of a dish. Turn the meat after half of the cooking time.	90 min
<b>Lamb</b> 				
P17	<b>Lamb leg with bones</b>	1,5 - 2 kg; 7 - 9 cm thick pieces	 <b>1</b> ; roasting dish on <b>baking tray</b> Add liquid. Turn the meat after half of the cooking time.	130 min
<b>Poultry</b> 				
P18	<b>Whole chicken</b>	1,1 kg; fresh	  <b>1</b> ; ceramic or glass casserole dish on <b>wire shelf</b> , MW suitable Use your favourite spices. Put the chicken breast-side down and turn it over after half of the cooking time.	40 min
P19	<b>Half chicken</b>	0,5 - 0,8 kg	 <b>2</b> ; <b>baking tray</b> Use your favourite spices.	40 min

# DAILY USE

	Dish	Weight	Shelf level / Accessory	Duration time
P20	<b>Chicken breast</b>	180 - 200 g per piece	  <b>1</b> ; casserole dish on <b>wire shelf</b> Use your favourite spices. Fry the meat for a few minutes on a hot pan.	25 min
P21	<b>Chicken legs, fresh</b>	-	 <b>2</b> ; <b>baking tray</b> If you marinated chicken legs first, set lower temperature and cook them longer.	30 min
P22	<b>Duck, whole</b>	2 - 3 kg	  <b>1</b> ; roasting dish on <b>wire shelf</b> Use your favourite spices. Put the meat on roasting dish. Turn the duck after half of the cooking time.	100 min
P23	<b>Goose, whole</b>	4 - 5 kg	  <b>?</b> ; <b>deep pan</b> Use your favourite spices. Put the meat on deep baking tray. Turn the goose after half of the cooking time.	110 min
<b>Other</b> 				
P24	<b>Meat loaf</b>	1 kg	 <b>1</b> ; <b>wire shelf</b> Use your favourite spices.	60 min
<b>Fish</b> 				
P25	<b>Whole fish, grilled</b>	0,5 - 1 kg per fish	 <b>1</b> ; <b>baking tray</b> Fill the fish with butter and use your favourite spices and herbs.	30 min
P26	<b>Fish fillet</b>	-	  <b>2</b> ; casserole dish on <b>wire shelf</b> Use your favourite spices.	20 min
<b>Sweet baking / desserts</b>   				
P27	<b>Cheesecake</b>	-	 <b>1</b> ;  28 cm springform tin on <b>wire shelf</b>	90 min
P28	<b>Apple cake</b>	-	 <b>2</b> ; <b>baking tray</b>	45 min





	Dish	Weight	Shelf level / Accessory	Duration time
P29	Apple tart	-	 1; pie form on <b>wire shelf</b>	40 min
P30	Apple pie	-	 1;  22 cm pie form on <b>wire shelf</b>	60 min
P31	Brownies	2 kg	 2; <b>deep pan</b>	30 min
P32	Chocolate muffins	-	 2; muffin tray on <b>wire shelf</b>	25 min
P33	Loaf cake	-	 1; loaf pan on <b>wire shelf</b>	50 min
<b>Vegetable / Side dishes</b>   				
P34	Baked potatoes	1 kg	 1; <b>baking tray</b> Put the whole potatoes with skin on baking tray.	50 min
P35	Wedges	1 kg	 2; <b>baking tray</b> lined with baking paper Use your favourite spices. Cut potatoes into pieces.	35 min
P36	Grilled mixed vegetables	1 - 1,5 kg	 2; <b>baking tray</b> lined with baking paper Use your favourite spices. Cut the vegetables into pieces.	30 min
P37	Croquets, frozen	0,5 kg	 2; <b>baking tray</b>	25 min
P38	Pommes, frozen	0,75 kg	 2; <b>baking tray</b>	25 min
<b>Gratins, bread and pizza</b>   				
P39	Meat / vegetable lasagna with dry noodle plates	1 - 1,5 kg	  1; ceramic or glass casserole dish on <b>wire shelf</b>	35 min

# CLOCK FUNCTIONS



	Dish	Weight	Shelf level / Accessory	Duration time
P40	<b>Potato gratin</b> (raw potatoes)	1,1 kg	  <b>2</b> ; ceramic or glass casserole dish on <b>wire shelf</b> Rotate the dish after half of the cooking time.	35 min
P41	<b>Pizza fresh, thin</b>	-	  <b>1</b> ; <b>baking tray</b> lined with baking paper	15 min
P42	<b>Pizza fresh, thick</b>	-	  <b>1</b> ; <b>baking tray</b> lined with baking paper	25 min
P43	<b>Quiche</b>	-	 <b>1</b> ; baking tin on <b>wire shelf</b>	45 min
P44	<b>Baguette / Ciabatta / White bread</b>	0,8 kg	  <b>1</b> ; <b>baking tray</b> lined with baking paper More time needed for white bread.	30 min
P45	<b>All grain / rye / dark bread all grain in loaf pan</b>	1 kg	  <b>1</b> ; <b>baking tray</b> lined with baking paper / <b>wire shelf</b>	60 min







## 7. CLOCK FUNCTIONS







### 7.1 Clock functions

Clock Function	Application
	Minute minder. When the timer ends, the signal sounds.
	Cooking time. When the timer ends, the signal sounds and the heating function stops.
	Time Delay. To postpone the start and / or end of cooking.
	Uptimer. Maximum is 23 h 59 min. This function has no effect on the operation of the oven. To turn on and off the Uptimer select: Menu, Settings.











## 7.2 How to set: Clock functions

How to set: Time of day		
Step 1	Step 2	Step 3
		
To change the time of day enter the menu and select Settings, Time of day.	Set the clock.	Press: OK.

How to set: Minute minder			
Step 1	The display shows: 0:00 	Step 2	Step 3
			
Press:  .		Set the Minute minder	Press: OK.
 Timer starts counting down immediately.			

How to set: Cooking time				
Step 1	Step 2	The display shows: 0:00  STOP	Step 3	Step 4
				
Choose a heating function and set the temperature.	Press repeatedly:  .		Set the cooking time.	Press: OK.
 Timer starts counting down immediately.				

# HOW TO USE: ACCESSORIES

How to set: Time Delay							
Step 1	Step 2		Step 3	Step 4		Step 5	Step 6
		The display shows: the time of day  START			The display shows: ---  STOP		
Select the heating function.	Press repeatedly: 		Set the start time.	Press: OK.		Set the end time.	Press: OK.
 Timer starts counting down at a set start time.							

## 8. HOW TO USE: ACCESSORIES

### 8.1 Inserting accessories

Use only suitable cookware and material. Refer to "Hints and tips" chapter, Microwave suitable cookware and materials.



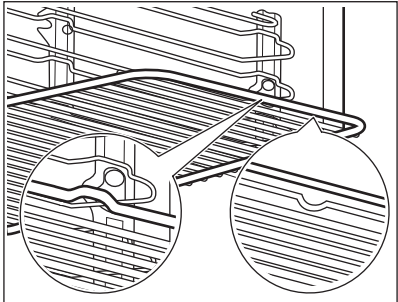
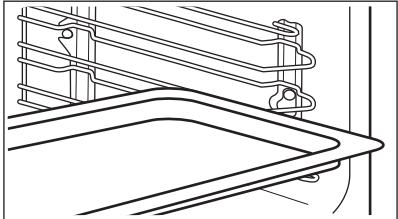

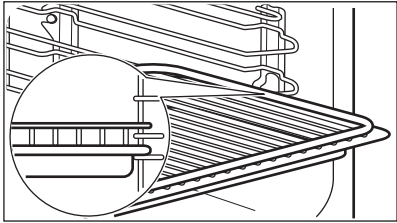
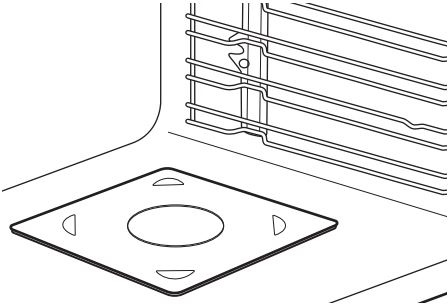
A small indentation at the top increases safety. The indentations are also anti-tip devices. The high rim around the shelf prevents cookware from slipping of the shelf.

<p><b>Wire shelf:</b> Push the shelf between the guide bars of the shelf support and make sure that the feet point down.</p>	
<p><b>Baking tray:</b> Push the tray between the guide bars of the shelf support.</p>	

<p><b>Wire shelf, Baking tray:</b> Push the tray between the guide bars of the shelf support and the wire shelf on the guide bars above.</p>	
<p><b>Microwave bottom glass plate:</b> Use the microwave bottom glass plate only with microwave function. It is not suitable for combined microwave function (e.g. microwave grilling). Put the accessory on the bottom of the cavity. You can put the food directly on the microwave bottom glass plate.</p>	

## 9. ADDITIONAL FUNCTIONS

### 9.1 Lock



<p>This function prevents an accidental change of the oven function.</p>		
<p>Turn it on when the oven works - the set cooking continues, the control panel is locked. Turn it on when the oven is off - the oven cannot be turned on, the control panel is locked.</p>		
	<p> OK - press and hold to turn on the function. A signal sounds.</p>	<p> OK - press and hold to turn it off.</p>
<p> 3 x  - flashes when the lock is turned on.</p>		

### 9.2 Automatic switch-off

For safety reasons the oven turns off after some time, if a heating function works and you do not change any settings.

# HINTS AND TIPS

---

 (°C)	 (h)
30 - 115	12.5
120 - 195	8.5
200 - 230	5.5

The Automatic switch-off does not work with the functions: Light, Time Delay.

## 9.3 Cooling fan

When the oven operates, the cooling fan turns on automatically to keep the surfaces of the oven cool. If you turn off the oven, the cooling fan can continue to operate until the oven cools down.

# 10. HINTS AND TIPS

---

## 10.1 Microwave recommendations

### **Let's cook!**

Place the food on the microwave bottom glass plate on the bottom of the cavity.

Place the food on a plate on the bottom of the cavity.

Turn or stir the food halfway through the defrosting and cooking time.

Stir liquid dishes from time to time.

Stir the food before serving.

Cover the food for cooking and reheating.

Put the spoon to the bottle or glass when heating drinks to ensure better heat distribution.

Put the food into the oven without packaging. The packaged ready meals can be put into the oven only when the packaging is microwave safe (check information on the packaging).



### **Microwave cooking**

Cook food covered. If you want to keep a crust cook food without a cover.

Do not overcook the dishes by setting the power and time too high. The food can dry out, burn or cause fire.

Do not use the oven to cook eggs or snails in their shells, because they can burst. Pierce the yolk of fried egg before reheating it.

Pierce food with skin or peel several times before cooking.

Cut vegetables into similar-sized pieces.

After you turn off the oven, take the food out and let it stand for a few minutes to allow the heat distribute evenly.



### **Microwave defrosting**

Put the frozen, unwrapped food on a small upturned plate with a container below it, or on a defrosting rack or plastic sieve so that the defrosting liquid can leak out.

Remove defrosted pieces subsequently.

To cook fruit and vegetables without defrosting them first, you can use a higher microwave power.



















## 10.2 Microwave suitable cookware and materials

For the microwave use only suitable cookware and materials. Use below table as a reference. Check the cookware / material specification before use.

## 10.3 Recommended power settings for different kinds of food

The data in the table is for guidance only.





700 - 1000 W				
 Cooking vegetables	 Searing at the start of the cooking process	 Heating liquids		
500 - 600 W				
 Cooking egg dishes	 Simmering stews	 Heating one-plate meals	 Defrosting and heating frozen meals	
300 - 400 W				
 Melting cheese, chocolate, butter	 Simmering rice	 Heating baby food	 Cooking / Heating delicate food	 Continuing cooking
100 - 200 W				
 Defrosting bread	 Defrosting fruit and cakes	 Defrosting cheese, cream, butter	 Defrosting meat, fish	







## 10.4 Cooking tables for test institutes

### Information for test institutes

Tests according to IEC 60705.

# HINTS AND TIPS

Use wire shelf unless otherwise specified.					
MICROWAVE FUNCTION	 (W)	 (kg)		 (min)	
Sponge cake	600	0.475	Bottom	7 - 9	Turn container around by 1/4, half-way through the cooking time.
Meatloaf	400	0.9	2	25 - 32	Turn container around by 1/4, half-way through the cooking time.
Egg custard	500	1	Bottom	18	-
Meat defrosting	200	0.5	Bottom	7 - 8	Turn the meat upside down half-way through the cooking time.

Use the wire shelf.						
MICRO-WAVE COMBI FUNCTION		 (W)	 (°C)		 (min)	
Cake, 0.7 kg	Conventional Cooking + MW	100	200	2	23 - 27	Turn container around by 1/4, halfway through the cooking time.
Potato gratin, 1.1 kg	True Fan Cooking + MW	300	180	2	38 - 42	Turn container around by 1/4, halfway through the cooking time.
Chicken, 1.1 kg	Turbo Grilling + MW	400	230	1	35 - 40	Put the meat in round glass container and turn it upside down half-way through the cooking time.



## 11. CARE AND CLEANING



### WARNING!

Refer to Safety chapters.

### 11.1 Notes on cleaning

 <b>Cleaning Agents</b>	<p>Clean the front of the oven with a soft cloth with warm water and a mild detergent.</p>
	<p>Use a cleaning solution to clean metal surfaces.</p>
	<p>Clean stains with a mild detergent.</p>
 <b>Everyday Use</b>	<p>Clean the cavity after each use. Fat accumulation or other residue may cause fire. Clean the oven ceiling carefully from residue and fat.</p>
	<p>Do not store the food in the oven for longer than 20 minutes. Dry the cavity with a soft cloth after each use.</p>
 <b>Accessories</b>	<p>Clean all accessories after each use and let them dry. Use a soft cloth with warm water and a mild detergent. Do not clean the accessories in a dishwasher.</p>
	<p>Do not clean the non-stick accessories using abrasive cleaner or sharp-edged objects.</p>

### 11.2 How to remove: Shelf supports

Remove the shelf supports to clean the oven.

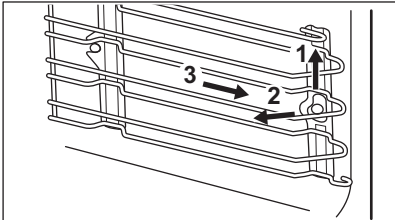
<b>Step 1</b>	Turn off the oven and wait until it is cold.	
<b>Step 2</b>	Carefully pull the shelf supports up and out of the front catch.	
<b>Step 3</b>	Pull the front end of the shelf support away from the side wall.	
<b>Step 4</b>	Pull the supports out of the rear catch.	

# TROUBLESHOOTING

Install the shelf supports in the opposite sequence.

## 11.3 How to replace: Lamp



### WARNING!

Risk of electric shock.  
The lamp can be hot.

Always hold the halogen lamp with a cloth to prevent grease residue from burning on the lamp.

Before you replace the lamp:

Step 1	Step 2	Step 3
Turn off the oven. Wait until the oven is cold.	Disconnect the oven from the mains.	Put a cloth on the bottom of the cavity.

## Top lamp

<b>Step 1</b>	Turn the glass cover to remove it.
<b>Step 2</b>	Clean the glass cover.
<b>Step 3</b>	Replace the lamp with a suitable 300 °C heat-resistant lamp.
<b>Step 4</b>	Install the glass cover.

# 12. TROUBLESHOOTING



### WARNING!

Refer to Safety chapters.

## 12.1 What to do if...

In any cases not included in this table please contact with an Authorised Service Centre.



**The oven does not turn on or does not heat up**

Problem	Check if...
You cannot activate or operate the oven.	The oven is correctly connected to an electrical supply.
The oven does not heat up.	The automatic switch-off is deactivated.



## The oven does not turn on or does not heat up

The oven does not heat up.	The fuse is not blown.
The oven does not heat up.	The Child Lock is off.



## Components

Problem	Check if...
The lamp does not work.	The lamp is burnt out.



## Error codes

The display shows...	Check if...
00:00	There was a power cut. Set the time of day.
If the display shows an error code that is not in this table turn the house fuse off and on to restart the oven. If the error code recurs contact an Authorised Service Centre.	

## 12.2 Service data

If you cannot find a solution to the problem yourself, contact your dealer or an Authorised Service Centre.

The necessary data for the service centre is on the rating plate. The rating plate is on the front frame of the oven cavity. Do not remove the rating plate from the oven cavity.

We recommend that you write the data here:	
Model (MOD.)	.....
Product number (PNC)	.....
Serial number (S.N.)	.....

## 13. ENERGY EFFICIENCY

### 13.1 Energy saving



The oven has features which help you save energy during everyday cooking.

Make sure that the oven door is closed when the oven operates. Do not open the oven door too often during cooking. Keep the door gasket clean and make sure it is well fixed in its position. Use metal cookware to improve energy saving (only when you use a non-microwave function). When possible, do not preheat the oven before cooking.

Keep breaks between baking as short as possible when you prepare a few dishes at one time.

#### Cooking with fan

When possible, use the cooking functions with fan to save energy.

#### Residual heat

The fan and lamp continue to operate. When you turn off the oven, the display shows the residual heat. You can use that heat to keep the food warm.

When the cooking duration is longer than 30 min, reduce the oven temperature to minimum 3 - 10 min before the end of cooking. The residual heat inside the oven will continue to cook. Use the residual heat to warm up other dishes.

#### Keep food warm

Choose the lowest possible temperature setting to use residual heat and keep a meal warm.

The residual heat indicator or temperature appears on the display.

#### Cooking with the lamp off

Turn off the lamp during cooking. Turn it on only when you need it.

## 14. MENU STRUCTURE

### 14.1 Menu

	≡ - select to enter the Menu.
--	-------------------------------

Menu structure	
Assisted Cooking	Settings



Step 1	Step 2	Step 3	Step 4	Step 5
 	 OK	 01 - 09	 OK	

# ENVIRONMENTAL CONCERNS

Select the Menu, Settings.	Confirm setting.	Select the setting.	Confirm setting.	Adjust the value and press OK.
----------------------------	------------------	---------------------	------------------	--------------------------------

Settings					
O1	Time of day	Change	O2	Display brightness	1 - 5
O3	Key tones	1 - Beep 2 - Click 3 - Sound off	O4	Buzzer volume	1 - 4
O5	Uptimer	On / Off	O6	Light	On / Off
O7	Demo mode	Activation code: 2468	O8	Software version	Check
O9	Reset all settings	Yes / No			

## 15. ENVIRONMENTAL CONCERNS

Recycle materials with the symbol . Put the packaging in relevant containers to recycle it. Help protect the environment and human health by recycling waste of electrical and electronic appliances. Do not dispose of appliances marked with the symbol  with the household waste. Return the product to your local recycling facility or contact your municipal office.

[www.aeg.com/shop](http://www.aeg.com/shop)



OK

867371339-A-062022

**AEG**