

Integrated Fridge Freezer with Twin Cooling Plus™



Feature	In this product	Description
Twin Cooling Plus™	✓	Wouldn't it be good if all your food in the fridge stayed really fresh? Samsung Twin Cooling Plus™ does exactly that with a precise fridge temperature control.
Total No Frost	✓	Wouldn't finding the ice cream be that bit easier with a frost free fridge freezer? Total No Frost prevents ice build up, saving you the time and hassle of defrosting.
SpaceMax™	✓	Now you can get the best of both worlds with SpaceMax™. Thin walls mean more space for food storage on the inside, while the outside size stays the same.
Cool Select +		With Smart Convertible Zone you control whether this huge compartment is used as a fridge or a freezer. There's a choice of four temperatures. And you can even customise the temperature of one section to perfectly chill or freeze your food.
Fresh Zone (Optimal + Humidity Fresh)	✓	Experience advanced fridge temperature control with the Humidity Fresh + drawer, letting you choose both the humidity and temperature to suit your chosen food and keep it fresh.
All Around Cooling		Moves cool air around the fridge to keep food fresh, with a constant temperature. So everything from chickens to cucumbers will be evenly chilled. Every item stays ideally cooled no matter where it's stored in the fridge.
Wi-Fi Embedded & SmartThings		Turn your home into a smarter home with SmartThings ¹ . SmartThings works with your smart devices to make your life easier, more secure and more entertaining than before.
SmartThings AI Energy Mode		Manage your energy usage to reduce your carbon footprint and save money. SmartThings Energy ¹ provides energy efficiency tips. It also monitors the energy consumption of appliances ² in real-time and compares it to the previous month. And it alerts you if your monthly targets might be exceeded.
Metal Cooling Plate	✓	Keep your food fresh, even if you frequently open and close the door. The Metal Cooling duct in the rear wall helps to maintain the optimal internal temperature. It retains the cold and prevents the loss of cool air when the door is open. And it quickly restores any heat loss when it's shut again.
Digital Inverter Compressor	✓	The Digital Inverter Compressor monitors and adjusts temperature to keep it constantly perfect, making for a more energy efficient fridge.
Variety Guard		No more items precariously wobbling in the door. Alter the position of the Adjustable Door Bins to fit whatever you need – from small juices to family-sized milk. It's a great way to make the best use of your space.
Easy Slide Shelf	✓	The Slide-in Shelf slides in and out easily to help you efficiently store, organize and access your food. So you can quickly find things, even if they are at the back or in the corners, with no "dead space".
Rack & Shelf™	✓	The specially designed wine shelf keeps your favourite tipples nice and chilled. And the extra wide wine rack means it's perfect for those slightly larger champagne bottles—so you're always ready for a toast. But if that's not to your taste, the new, flatter design is ideal for storing wide items, like pizzas, that can be difficult to place. It's a multifunctional wonder.
Power Cool	✓	Lost some cool air while stocking the fridge with your weekly shop? Power Cool tops it up with an extra burst of cooling to bring the fridge's temperature back down. So your new food will stay nice and fresh.
Power Freeze	✓	Power Freeze rapidly lowers the temperature of the freezer, once you've stocked up. No more worrying about your frozen favourites defrosting.
Optimal Fresh+		The Optimal Fresh + box features two temperature zones, so you can maximise the freshness of different foods at the same time. Store two meats and fish in the left side where it's cooler, and keep your fruit and veg at its best on the right. Or, you can set it for a single temperature to maximise space. It's that easy for you to keep food fresh.
5 Year Warranty	✓	Samsung freestanding Fridge Freezers are as durable as they are innovative. But just in case, we give you a 5 year warranty.

¹ Available on Android and iOS devices. A Wi-Fi connection and a Samsung account are required.

² SmartThings Energy currently works with around 40 Samsung home appliances that are SmartThings enabled. These include washing machines, clothes dryers, dish washers, air conditioners, air purifiers, vacuum cleaners, ovens, hoods, cooktops, microwave ovens, TVs (from June 2022) and energy meters.

Key Specifications

Y = Yes
N = No

Product	BRB26705DWW/EU
Type	Integrated
EAN	8806092211315
Warranty (Years)	5
Colour	White
Gross Capacity (L)	264
Cooling Technology	Twin Cooling
Net Product Width (mm)	540
Net Product Height (mm)	1775
Net Product Depth (mm)	550
SmartThing / WiFi	N
Plumbed / Non-Plumbed	Non-Plumbed

General Specifications

Net Product Weight (KG)	68
Box Width (mm)	600
Box Height (mm)	1864
Box Depth (mm)	629
Box Weight (KG)	70
No. of Doors	2
Fridge/Freezer Split	72/28
Door Hinge	Slide Hinge
Reversible Door	Y
Shelf Type	Tempered Glass
Hot Stamping	N
Rear panel Material	Flame Retardant Metal Back
Energy Consumption (kWh/YR)	185
Noise (dB)	35
Noise grade	B
Climate Class	SN/T
Family Hub™	N
Beverage Centre™	N
Food Showcase Door™	N
SpaceMax™	Y
Total No Frost	Y
Metal Cooling	Y
Optimal Fresh +	Y
Smart Conversion™	N
Cool Select +	Y
Flex Crisper + (M+F)	N
Crisper + (F+V)	N

Humidity Fresh	Y
Café Dispenser	N
Power Cool	Y
Power Freeze	Y
Compressor	Digital Inverter
HomeBar	N
Holiday Mode	Y
Recess height	1778
Recess depth	560
Recess width	555
Plug supplied	UK (3 Pin)
Plug amperage	3A
Hose length	N/A
Fridge	
Internal Temperature Range (°C)	1 ~ 7 °C
Storage capacity (L)	190
Refrigerant	R600a
Number of shelves	3
Number of Fruit & Vegetable Drawers	2
Number of door compartments	6
Adjustable Humidity Drawer	Y
Adjustable shelves	Y
Interior light	Y
Interior light type	LED
Egg tray	Y
Wine rack	Y
Dairy compartment	N
Freezer	
Internal Temperature Range (°C)	-20 ~ 5 °C
Freezer Position	Bottom
Storage Capacity (L)	74
Freezer * Rating	4
Power failure safe-storage time (Hours)	6 hours
Freezing capacity (kg/24H)	6 kg/24h
Number of storage Shelves	2
Number of storage Drawers	1
Number of storage Baskets	0
Number of door compartments	0
Interior light	Y
Interior light type	LED
Ice Producer	Y
Water dispenser	N
Ice dispenser	N
Crushed ice dispenser	N
Cubed ice dispenser	N

Technical Drawings

Installation

Clearance

See the following figures and tables for space requirements for installation.

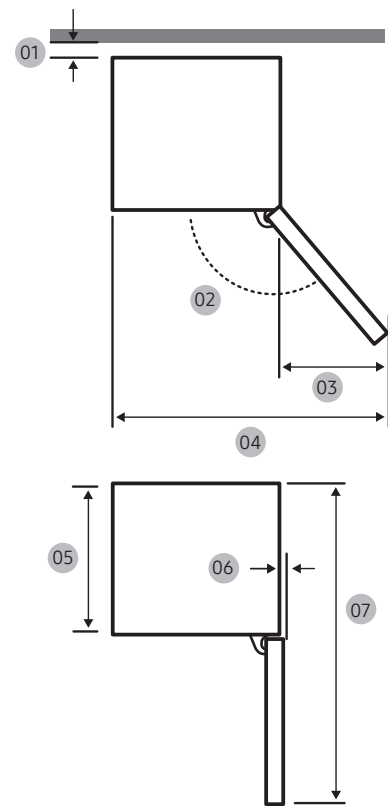
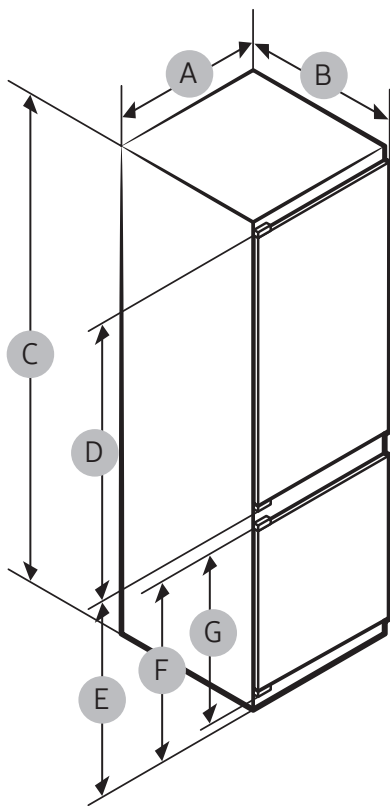

	BRB26*0* / BRB26*1*	BRB30*0* / BRB30*1*
A	540±2	540±2
B	550±2	550±2
C	1775±2	1935±2
D	987	1147
E	735	735
F	671	671
G	621	621

(unit : mm)

Model	BRB26*0* BRB30*0* SLIDE TYPE	BRB26*1* BRB30*1* FIXED TYPE
01 *	10 (Min.) / 30 (Recommended)	
02	95° (Recommended)	115° (Recommended)
03	218	180
04	758	700
05	510	510
06	1	5
07	1055	1055

* 01 : From cabinet to rear of product.

(unit : mm)

Energy Labels



SAMSUNG

BRB26705DWW

SAMSUNG

BRB26705DWW



185 kWh/annum

185 kWh/annum



74 L



190 L



74 L



190 L



A **B**CD

2019/2016

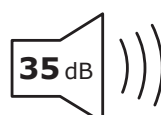

A **B**CD

2019/2016