

# LAMONA

at the heart of the kitchen

## Built-in Double Oven

LAM4609



## Instructions and Installation

ISSUE v2 120623

Register   
my appliance

[www.howdens.com/appliance-registration](http://www.howdens.com/appliance-registration)



# Free 3 year guarantee

**Call now<sup>1</sup>**

Within the UK:

**0333 010 0009**

Within Republic of Ireland:

**01525 5752**

Alternatively, visit [www.howdens.com/appliance-registration](http://www.howdens.com/appliance-registration)

# LAMONA

**3 year guarantee available.  
Register your appliance within 90 days<sup>2</sup>**

**By registering your appliance and creating an account, we will keep you up to date with the latest product information and notify you immediately of any important product updates**

<sup>1</sup>Lines are open Monday to Friday 9am to 5pm. Calls will be charged at your local rate and may be recorded and monitored for training and quality purposes.

<sup>2</sup>So that in the event of an important product update, or recall, we can contact you.

**Register**   
**my appliance**

## Welcome

Dear Customer,







Congratulations on your choice of oven.

### The user manual will help you use your product quickly and safely.

- Please read this user manual before installing and using the oven.
- Always follow the safety instructions.
- Keep this user manual within easy reach for future reference.
- Register your appliance to access a digital copy of your user manual for future reference.
- Please read any other documents supplied with the product.

### Explanation of symbols

Throughout this manual the following symbols are used.

	Warning for possible hazards to health and property.
	Warning possibility of an electric shock.
	Warning of risk of fire.
	Warning of hot surfaces.
	Important information or useful usage tips.
	Read the user manual.

# Contents

<b>1. Important instructions and warnings for safety and environment</b>	<b>5</b>	<b>6. How to operate the oven</b>	<b>22</b>
General safety	5	General information on baking, roasting and grilling	22
Electrical safety	6	How to operate the electric oven	23
Product safety	6	Rack positions (for models with wire shelf)	24
Intended use	8	Operating modes	25
Safety for children	8	Cooking by setting the cooking time	26
General warnings about cooking in the oven	9	Settings	28
<b>2. Environmental instructions</b>	<b>10</b>	Cooking times table	32
Waste regulation	10	How to operate the top oven	34
Package information	10	Cooking times table	35
Future transportation	10	How to operate the top grill	36
<b>3. General information</b>	<b>11</b>	Top oven cooking times table for grilling with electric grill	37
Overview	11	<b>7. Maintenance and care</b>	<b>38</b>
Package contents	12	General cleaning information	38
Technical specifications	13	Cleaning the accessories	40
<b>4. Installation</b>	<b>14</b>	Cleaning the control panel	40
Before installation	14	Cleaning the inside of the oven (cooking area)	40
Installation and connection	16	Cleaning the oven door	40
Electrical connections	16	Removing the inner glass door	42
Connecting the power cable	16	Cleaning the oven lamp	43
Future transportation	18	Replacing the oven lamp	43
<b>5. Preparation</b>	<b>19</b>	<b>8. Troubleshooting</b>	<b>44</b>
Tips for saving energy	19	<b>9. Your guarantee</b>	<b>45</b>
Initial use and time setting	19		
First cleaning of the appliance	21		
Initial heating	21		
Electric oven	21		

# 1. Important instructions and warnings for safety and environment

This section contains safety instructions that will help protect from risk of personal injury or property damage. Failure to follow these instructions shall void any warranty.

## General safety

- This appliance can be used by children aged from 8 years and above and persons with reduced physical, sensory or mental capabilities or lack of experience and knowledge if they have been given supervision or instruction concerning use of the appliance in a safe way and understand the hazards involved.

Children shall not play with the appliance. Cleaning and user maintenance shall not be made by children without supervision.

- The appliance is not to be used by persons (including children) with reduced physical, sensory or mental capabilities, or lack of experience and knowledge, unless they have been given supervision or instruction.

Children should be supervised and ensure they do not play with the appliance.

If the product is handed over to someone else for personal use or second-hand use purposes, the user manual, product labels and other relevant documents and parts should be also given.

- Installation and repair procedures must always be performed by Authorised Service Agents. The manufacturer shall not be held responsible for damages arising from procedures carried out by unauthorised persons which may also void the warranty. Before installation, read the instructions carefully.
- Do not operate the product if it is defective or has any visible damage.
- Ensure that the product function knobs are switched off after every use.
- **Do not place aluminium foil on the base of the baking tray.**



## Electrical safety

---

- If the product has a failure, it should not be operated unless it is repaired by an Authorised Service Agent. There is the risk of an electric shock!
- Only connect the product to a grounded outlet / line with the voltage and protection as specified in the “Technical specifications”. Have the grounding installation made by a qualified electrician while using the product with or without a transformer. Our company shall not be liable for any problems arising due to the product not being earthed in accordance with the local regulations.
- Never wash the product by spreading or pouring water onto it! There is the risk of an electric shock!
- The product must be disconnected during installation, maintenance, cleaning and repairing procedures.
- If the power connection cable for the product is damaged, it must be replaced by the manufacturer, its service agent or similarly qualified persons in order to avoid a hazard.
- Only use the connection cable specified in the “Technical specifications”.
- The appliance must be installed so that it can be completely disconnected from the mains supply. The separation must be provided by a switch built into the fixed electrical installation, according to construction regulations.
- Rear surface of the oven gets hot when it is in use. Make sure that the electrical connection does not contact with the rear surface; otherwise, connections can get damaged.
- Do not trap the mains cable between the oven door and frame and do not route it over hot surfaces. Otherwise, cable insulation may melt and cause fire as a result of short circuit.
- Any work on electrical equipment and systems should only be carried out by authorised and qualified persons.
- In case of any damage, switch off the product and disconnect it from the mains. To do this, turn off the fuse at home.
- Make sure that fuse rating is compatible with the product.

## Product safety

---



**WARNING!** The appliance and its accessible parts become hot during use. Care should be taken to avoid touching heating elements. Children less than 8 years of age shall be kept away unless continuously supervised.

- Never use the product when your judgment or coordination is impaired by the use of alcohol and / or drugs.

- Be careful when using alcoholic drinks in your dishes. Alcohol evaporates at high temperatures and may cause fire since it can ignite when it comes into contact with hot surfaces.
- Food Poisoning Hazard: Do not let food sit in oven for more than 1 hour before or after cooking. Doing so can result in food poisoning or sickness.
- Do not place any flammable materials close to the product as the sides may become hot during use.
- During use the appliances becomes hot. Care should be taken to avoid touching heating elements inside the oven.
- Keep all ventilation slots clear of obstructions.
- Do not heat closed tins and glass jars in the oven. The pressure that would build-up in the tin/jar may cause it to burst.
- Do not place baking trays, dishes or aluminium foil directly onto the bottom of the oven. The heat accumulation might damage the bottom of the oven.
- Do not use harsh abrasive cleaners or sharp metal scrapers to clean the oven door glass since they can scratch the surface, which may result in shattering of the glass.
- Do not use steam cleaners to clean the appliance as this may cause an electric shock.
- (Varies depending on the product model.) Placing the wire shelf and tray onto the wire racks properly It is important to place the wire shelf and / or tray onto the rack properly. Slide the wire shelf or tray between 2 rails and make sure that it is balanced before placing food on it (Please see the following figure).



- Do not use the product if the front door glass is removed or cracked.
- Always use heat resistant oven gloves when putting in or removing dishes into/from the hot oven.
- Place the baking paper into the cooking pot or on to the oven accessory (tray, wire grill etc.) together with the food and then insert all into the preheated oven. Remove the excess parts of the baking paper overflowing from the accessory or the pot in order to prevent the risk of touching the oven's heating elements.

Never use the baking paper in an operating temperature higher than the indicated value for the baking paper. Do not place the baking paper directly on the base of the oven.



**WARNING!** Ensure that power cord of the appliance is disconnected or circuit breaker is switched off before replacing the lamp to avoid the possibility of an electric shock.

- The appliance must not be installed behind a decorative door in order to avoid overheating.

Prevention against possible fire risk!

- Ensure all electrical connections are secure and tight to prevent risk of arcing.
- Do not use damaged cables or extension cables.
- Ensure liquid or moisture is not accessible to the electrical connection point.

## Intended use

- This product is designed for domestic use. Commercial use will void the guarantee.
- **CAUTION:** This appliance is for cooking purposes only. It must not be used for other purposes, for example room heating.
- This product should not be used for warming the plates under the grill, drying towels, dish cloths etc. by hanging them on the

oven door handles. This product should also not be used for room heating purposes.

- The manufacturer shall not be liable for any damage caused by improper use or handling errors.
- The oven can be used for defrosting, baking, roasting and grilling food.

## Safety for children



**WARNING!** Accessible parts may become hot during use. Young children should be kept away.

- The packaging materials will be dangerous for children. Keep the packaging materials away from children. Please dispose of all parts of the packaging according to environmental standards.
- Electrical products are dangerous to children. Keep children away from the product when it is operating and do not allow them to play with the product.
- Do not place any items above the appliance that children may reach for.
- When the door is open, do not load any heavy object on it and do not allow children to sit on it. It may overturn or door hinges may get damaged.



## General warnings about cooking in the oven



**WARNING!** Risk of fire!

- Do not place aluminium foil or baking trays on the base of the oven when in use. Heat is reflected downwards and can damage the oven and the cabinets beneath.
- Do not line the grill tray or any baking trays with aluminium foil. The reflected heat can damage the heater.



## 2. Environmental instructions

### Waste regulation

#### Disposing of the old product. Compliance with the WEEE Directive and disposing of the waste product:



This product complies with EU WEEE Directive (2012/19/EU). This product bears a classification symbol for waste electrical and electronic equipment (WEEE).

This product has been manufactured with high quality parts and materials which can be reused and are suitable for recycling. Do not dispose of the waste product with normal domestic and other wastes at the end of its service life. Take it to the collection centre for the recycling of electrical and electronic equipment. Please consult your local authorities to learn about these collection centres. Appropriate disposal of used appliance helps prevent potential negative consequences for the environment and human health.

#### Compliance with RoHS Directive:

The product you have purchased complies with EU RoHS Directive (2011/65/EU). It does not contain harmful and prohibited materials specified in the Directive.

### Package information

- Packaging materials of the product are manufactured from recyclable materials in accordance with our National Environment Regulations. Do not dispose of the packaging materials together with the domestic or other wastes. Take them to the packaging material collection points designated by the local authority.

### Future transportation

- Keep the product's original carton and transport the product in it. Follow the instructions on the carton. If you do not have the original carton, pack the product in bubble wrap or thick cardboard and tape it securely.



Check the general appearance of your product for any damages that might have occurred during transportation.

### 3. General information

#### Overview

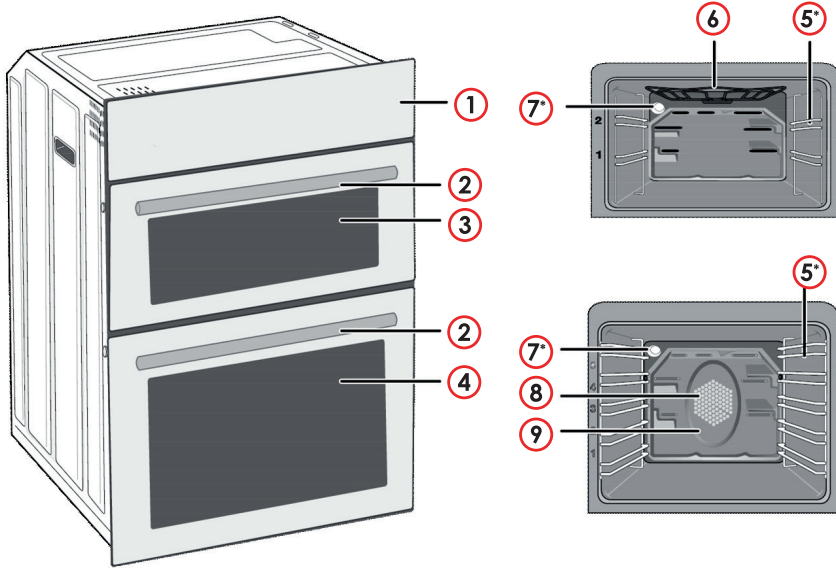

- ① Control panel
- ② Handle
- ③ Top oven
- ④ Main oven
- ⑤ Shelf positions\*
- ⑥ Grill heating element
- ⑦ Lamp\*
- ⑧ Fan motor (behind steel plate)
- ⑨ Ring heater

\* (This feature is optional. It may not exist on your product.)

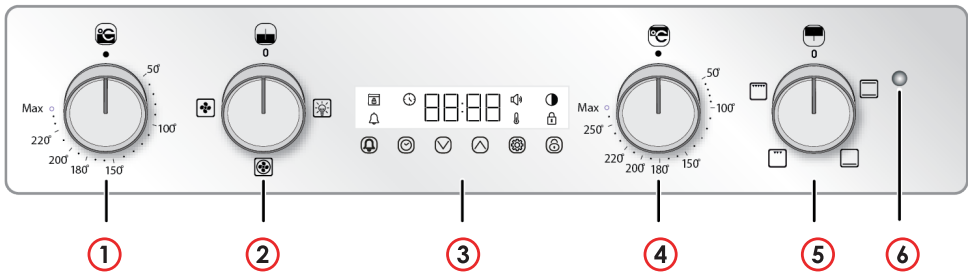

- ① Main oven thermostat knob
- ② Main oven function knob
- ③ Digital timer
- ④ Top oven thermostat knob
- ⑤ Top oven function knob
- ⑥ Top oven thermostat lamp

## Package contents

---

**i** Accessories supplied can vary depending on the product model. Not every accessory described in the user manual may exist on your product.

### 1. User manual

### 2. Standard tray

Used for pastries, frozen foods and big roasts.



### 4. Small wire shelf

It is placed into the tray (if supplied) in order to collect the dripping fat while grilling so that the oven is kept clean.

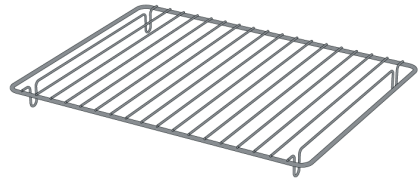

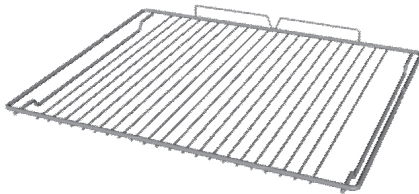

### 3. Wire grill

Used for roasting and for placing the food to be baked, roasted or cooked in casserole dishes to the desired rack.



<b>Technical specifications</b>	
<b>General</b>	
Voltage / frequency	220 - 240 V ~ 50 Hz
Total power consumption	4,3 kW
Fuse	25 A
Cable type / section	Min. H05VV-FG 3 x 2,5mm <sup>2</sup> or equivalent
<b>Oven / grill</b>	
External dimensions (height / width / depth)	890mm / 594mm / 567mm
Installation dimensions (height / width / depth)	880mm / 560mm / min. 550mm
Main oven	<b>Fan oven</b>
Inner lamp type	25 W, G9, 300°C
Top oven	<b>Conventional oven / grill</b>
Inner lamp type (B)	25 W, G9, 300°C
Grill power consumption	2,5 kW

**Basics:** Information on the energy label of electrical ovens is given in accordance with the EN 60350-1 / IEC 60350-1 standard. Those values are determined under standard load with bottom-top heater or fan assisted heating (if any) functions. Energy efficiency class is determined in accordance with the following prioritisation depending on whether the relevant functions exist on the product or not. 1-Cooking with eco-fan, 2-Turbo slow cooking, 3-Turbo cooking, 4-Fan assisted bottom/top heating, 5-Top and bottom heating.

-  Technical specifications may be changed without prior notice to improve the quality of the product.
-  Figures in this manual are schematic and may not exactly match your product.
-  Values stated on the product labels or in the documentation accompanying it are obtained in laboratory conditions in accordance with relevant standards. Depending on operational and environmental conditions of the product, these values may vary.

## 4. Installation

Product must be installed by a qualified person in accordance with the regulations in force. The manufacturer shall not be held responsible for damages arising from procedures carried out by unauthorised persons which may also void the warranty.

 Preparation of location and electrical installation for the product is under the installer's responsibility.



 The product must be installed in accordance with all local electrical regulations.

 Prior to installation, visually check if the product has any defects on it. If so, do not have it installed. Damaged products cause risks for your safety.

### Before installation

The appliances must not be installed behind a decorative door in order to avoid overheating.

The appliance is intended for installation in commercially available kitchen cabinets. A safety distance must be left between the appliance and the kitchen walls and furniture. See figure (values in mm).

- Surfaces, synthetic laminates and adhesives used must be heat resistant (100°C minimum).
  - Kitchen cabinets must be set level and fixed.
  - If there is a drawer beneath the oven, a shelf must be installed in order to separate from the oven and drawer.
  - Carry the appliance with at least two persons.
  - Hold the oven from the slots for handling on both sides to move it.
  - Before installing the product, remove all materials and documents inside.
  - Kitchen furniture must be in compliance with the dimensions given in the figure below. At the rear section of the kitchen furniture, an opening must be cut out with the dimensions given in the figure below to ensure sufficient ventilation.
  - The following installation drawings are representational and may not match exactly with your appliance.
-  Do not install the appliance next to refrigerators or freezers. The heat emitted by the appliance will lead to an increased energy consumption of cooling appliances.
-  The door and / or handle must not be used for lifting or moving the appliance.

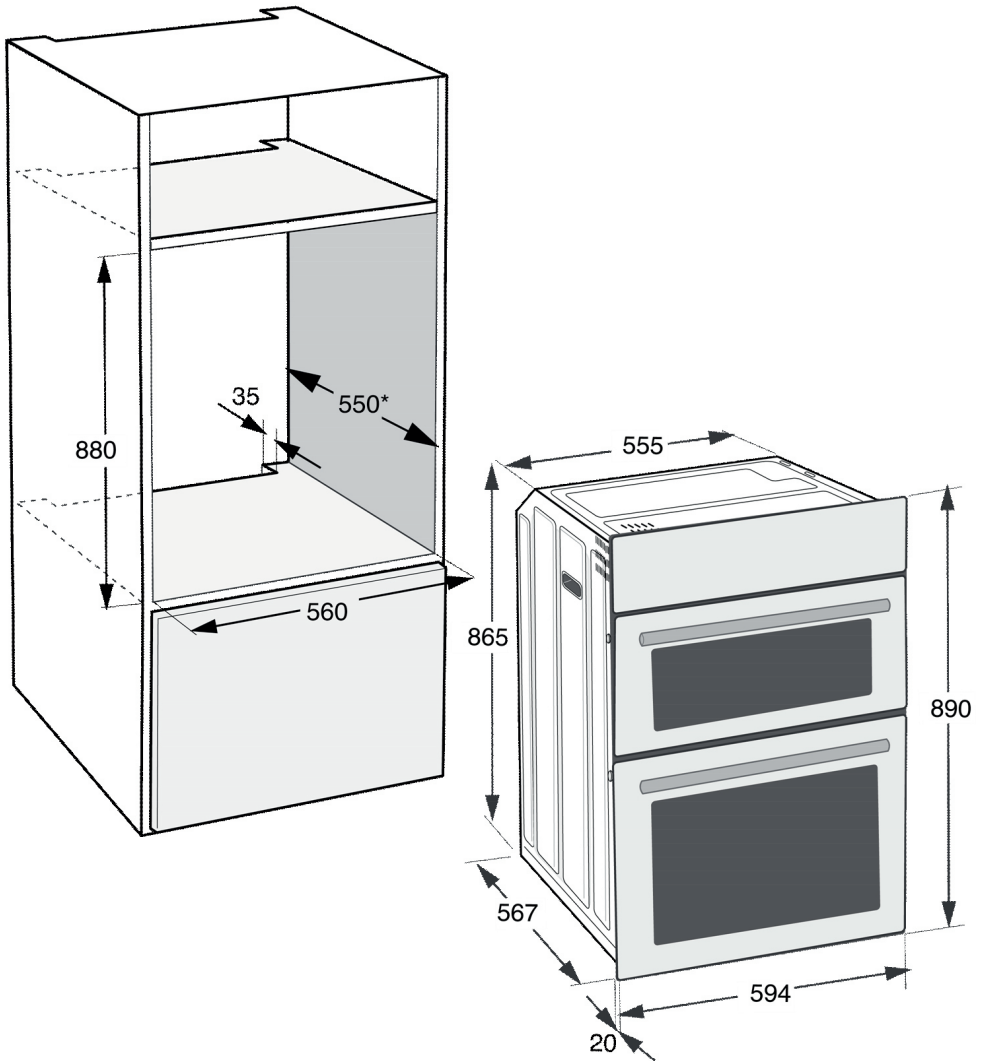

\* Min.  
All installation dimensions shown are in millimetres.

## Installation and connection

- The product must be installed in accordance with all local gas and electrical regulations.

## Electrical connections

- **⚠ IMPORTANT: Ensure that the electricity supply is switched off before connecting. Your oven is intended for permanent installation.**
- Your appliance must be connected to fixed wiring via the use of a double pole switched outlet with at least 3mm contact separation. The isolation switch must be accessible after installation (see technical data for fuse rating). We recommend the use of an RCD device as additional protection.
- We strongly recommend the appliance is connected by a qualified electrician who is a member of the N.I.C.E.I.C who will comply with the I.E.E and any local regulations.
- The terminology DOUBLE POLE -/+ means that both the live and neutral supplies are switched and disconnected at the same time.
- The terminations labelled SUPPLY are connections for the internal house wiring and the terminations labelled LOAD are for connection to the appliance.

## Connecting the power cable

- **⚠ IMPORTANT: The wires in the mains lead are coloured in accordance with the following code:**

**BLUE** = Neutral

**BROWN** = Live

**GREEN / YELLOW** = Earth

- As the colours of the wires in the mains lead of this appliance may not correspond with the coloured markings identifying the terminals in your spur box, proceed as follows;
- The wire which is coloured blue must be connected to the terminal which is marked with the letter 'N' or coloured 'BLACK'. The wire which is coloured brown must be connected to the terminal which is marked with the letter 'L' or coloured RED. The green and yellow earth 'E' should be connected to the terminal marked with the following symbol .

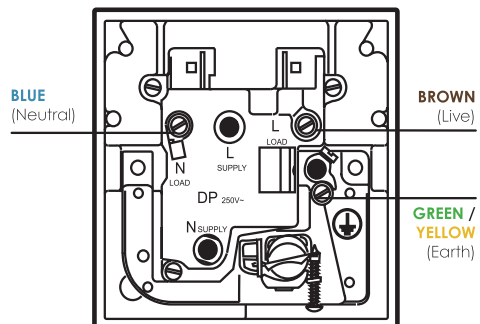



**IMPORTANT:** The appliance may be connected to the mains supply only by a competent person.

The mains lead must not be clamped, bent, trapped, or come into contact with hot parts of the appliance.

**IMPORTANT:** If the mains lead is damaged, it must be replaced by a qualified person (mains cable must not be longer than 2m for safety reasons). It should be routed away from the appliance and not trapped between the appliance and the wall.

2. Pass the mains lead under the cable clamp and secure clamp with the screw over the outer cable insulation.
3. Connect the cables according to the supplied diagram.
4. Close the cover of the terminal block once the wiring is complete.
5. Mains cable must not be longer than 2 metres for safety reasons.
6. The mains lead should be routed away from the appliance and not be trapped between the appliance and the wall.

### European Terminals

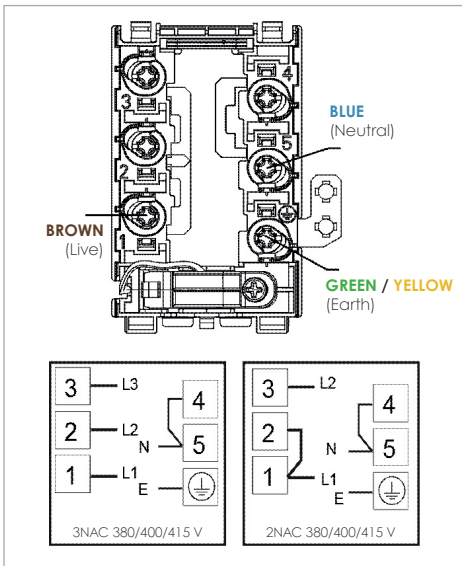

Your oven comes pre-fitted with a mains cable. If you need to change it:

1. Open the terminal block cover with screwdriver.

### Cooling fan

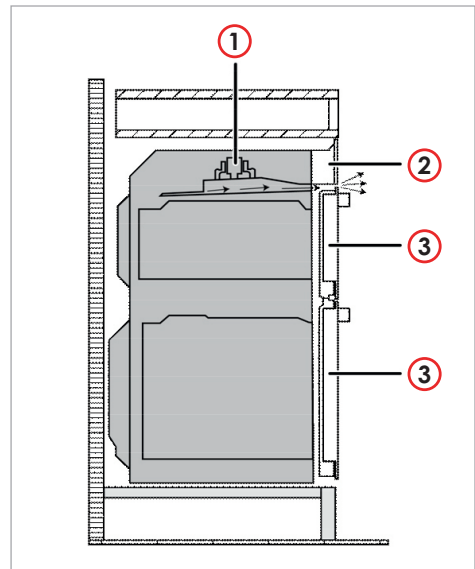

- 1 Cooling fan**
- 2 Control panel**
- 3 Door**

The built-in cooling fan cools both the built-in cabinet and the front of the product.

**i** Cooling fan continues to operate for about 20 to 30 minutes after the oven is switched off.

If you have cooked by programming the timer of the oven, cooling fan will also be switched off at the end of the cooking time together with all functions.

### Final check

1. Operate the product.
2. Check the functions.

### Future transportation

---

- Keep the product's original carton and transport the product in it. Follow the instructions on the carton. If you do not have the original carton, pack the product in bubble wrap or thick cardboard and tape it securely.
- To prevent the wire grill and tray inside the oven from damaging the oven door, place a strip of cardboard onto the inside of the oven door that lines up with the position of the trays. Tape the oven door to the side walls.
- Do not use the door or handle to lift or move the product.
- **i** Do not place any objects onto the product and move it in upright position.
- **i** Check the general appearance of your product for any damages that might have occurred during transportation.

## 5. Preparation

### Tips for saving energy

The following information will help you to use your appliance in an ecological way, and to save energy:

- Use dark coloured or enamel coated cookware in the oven since the heat transmission will be better.
- While cooking your dishes, perform a preheating operation if it is advised in the user manual or cooking instructions.
- Do not open the door of the oven frequently during cooking.
- Try to cook more than one dish in the oven at the same time whenever possible. You can cook by placing two cooking vessels onto the wire shelf.
- Cook more than one dish one after another. The oven will already be hot.
- You can save energy by switching off your oven a few minutes before the end of the cooking time. Do not open the oven door.
- Defrost frozen dishes before cooking them.

### Initial use and time setting

**i** Always set the time of day before using your oven. If you do not set it, you cannot cook in some oven models.

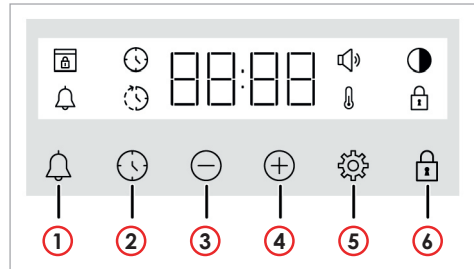

- ① Alarm key
- ② Time setting key
- ③ Decrease key
- ④ Increase key
- ⑤ Settings key
- ⑥ Key lock key

### Display symbols

- 🕒 : Cooking time symbol
- 🕒⌚ : Cooking end time symbol\*
- 🔔 : Alarm symbol
- 🌙 : Brightness symbol
- 🔒 : Key lock symbol
- 🌡️ : Temperature symbol
- 🔊 : Volume symbol
- 🔒🚪 : Door lock symbol\*

\* It varies depending on the product model. It may not be available on your product.

1. When after the oven is energised for the first time, hour field "12:00" and ⌚ symbol will flash on the display.
2. Set the time of day by touching the ⊕ ⊖ keys.

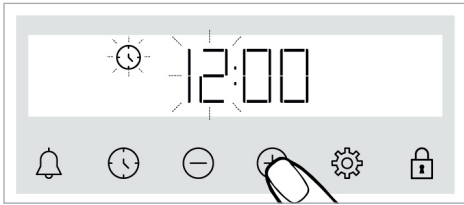

3. Touch ⌚ or ⚙ key to activate the minute field.

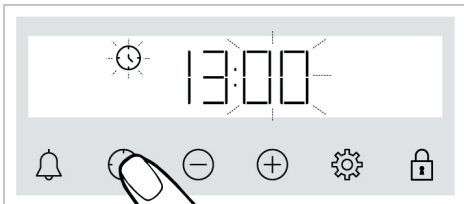

4. Set the minute of day by touching the ⊕ ⊖ keys.

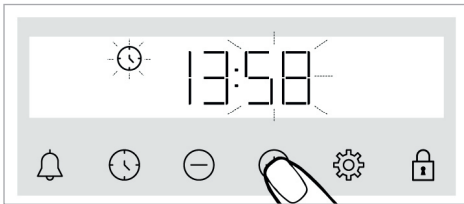

5. Confirm the setting by touching the ⌚ or ⚙ key.
- » The time of day is set and the ⌚ symbol disappears on the screen.

**i** If the first time is not set, "12:00" and ⌚ symbols continue to flash and your oven will not start. For your oven to work, you must confirm the time of the day by setting the time of the day or touching the ⌚ key when it is at "12:00". You can change the time of day setting later, as described in the "Settings" section.

**i** Current time settings are cancelled in case of power failure. It needs to be re-adjusted.

## First cleaning of the appliance

**i** The surface might get damaged by some detergents or cleaning materials.

Do not use aggressive detergents, cleaning powders / creams or any sharp objects during cleaning. Do not use harsh abrasive cleaners or sharp metal scrapers to clean the oven door glass since they can scratch the surface, which may result in shattering of the glass.

1. Remove all packaging materials.
2. Wipe the surfaces of the appliance with a damp cloth or sponge and dry with a cloth.

## Initial heating

Heat up the product for about 30 minutes and then switch it off. Thus, any production residues or layers will be burnt off and removed.



Hot surfaces cause burns! Product may be hot when it is in use. Never touch the hot burners, inner sections of the oven, heaters and etc. Keep children away. Always use heat resistant oven gloves when putting in or removing dishes into/from the hot oven.

## Electric oven

1. Take all baking trays and the wire grill out of the oven.
2. Close the oven door.
3. Select Static position.
4. Select the highest grill power; See "How to operate the electric oven", page 23.
5. Operate the oven for about 30 minutes.
6. Turn off your oven; See "How to operate the electric oven", page 23.



Smoke and smell may emit for a couple of hours during the initial operation. This is quite normal. Ensure that the room is well ventilated to remove the smoke and smell. Avoid directly inhaling the smoke and the smell that emits.

## 6. How to operate the oven

### General information on baking, roasting and grilling



Hot surfaces cause burns! Product may be hot when it is in use. Never touch the hot burners, inner sections of the oven, heaters and etc. Keep children away. Always use heat resistant oven gloves when putting in or removing dishes into/from the hot oven.



Be careful when opening the oven door as steam may escape. Exiting steam can scald your hands, face and/or eyes.

- It takes about 15 to 30 minutes longer to roast meat with bones when compared to roasting the same size of meat without bones.
- Each centimetre of meat thickness requires approximately 4 to 5 minutes of cooking time.
- Let meat rest in the oven for about 10 minutes after the cooking time is over. The juice is better distributed all over the roast and does not run out when the meat is cut.
- Fish should be placed on the middle or lower rack in a heat-resistant plate.

### Tips for baking

- Use non-sticky coated appropriate metal plates or aluminium vessels or heat-resistant silicone moulds.
- Make best use of the space on the rack.
- Place the baking mould in the middle of the shelf.
- Select the correct rack position before turning the oven or grill on. Do not change the rack position when the oven is hot.
- Keep the oven door closed.

### Tips for roasting

- Treating whole chicken, turkey and large piece of meat with dressings such as lemon juice and black pepper before cooking will increase the cooking performance.

### Tips for grilling

- When meat, fish and poultry are grilled, they quickly get brown, have a nice crust and do not get dry. Flat pieces, meat skewers and sausages are particularly suited for grilling as are vegetables with high water content such as tomatoes and onions.
- Distribute the pieces to be grilled on the wire shelf or in the baking tray with wire shelf in such a way that the space covered does not exceed the size of the heater.
- Slide the wire shelf or baking tray with grill into the desired level in the oven. If you are grilling on the wire shelf, slide the baking tray to the lower

rack to collect fats. The baking tray to be slid must be of a size that covers the whole grilling area. This tray might not be provided with the product. Add some water in the baking tray for easy cleaning.



**WARNING!** Foods that are not suitable for grilling carry the risk of fire. Only grill food which is suitable for intensive grilling heat.

Do not place the food too far in the back of the grill. This is the hottest area and fatty food may catch fire.

## How to operate the electric oven

Product is equipped with two ovens. Overview section indicates the relevant knobs for each oven.

### How to operate the main oven

#### Select temperature and operating mode

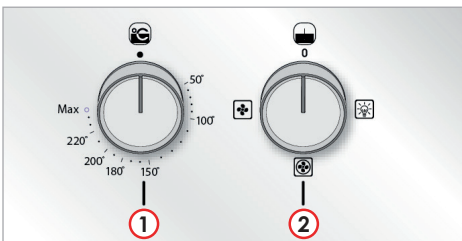

- ① Main oven thermostat knob
- ② Main oven function knob

### Turning on the oven

When you select a operating function you want to cook with using the function selection knob and set a certain temperature with using the temperature knob, the oven starts operating.

### Turning off the oven

You can turn the oven off by turning the function selection knob and temperature knob to the off (up) position.



### Manual cooking to select temperature and oven operating function

You can cook by making a manual control (at your own control) without setting the cooking time by selecting the temperature and operating function specific to your food.

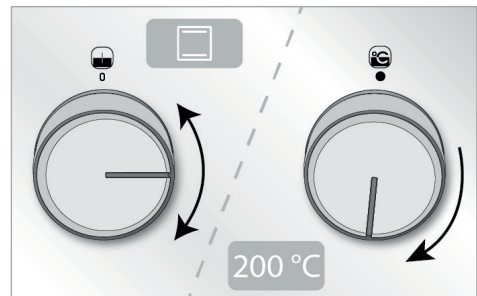
Example:



1. Select the operating function you want to cook using the function selection knob.
2. Set the temperature you want to cook using the temperature knob.

» Your oven will start operating immediately at the selected function and temperature and  will appear on the screen. When the temperature inside the oven reaches the set temperature, the  symbol disappears. The oven does not switch off automatically since manual cooking is done without setting the cooking time. You have to control cooking yourself and turn it off. When your cooking is completed, turn off the oven by turning the function selection knob and the temperature knob to the off (up) position.

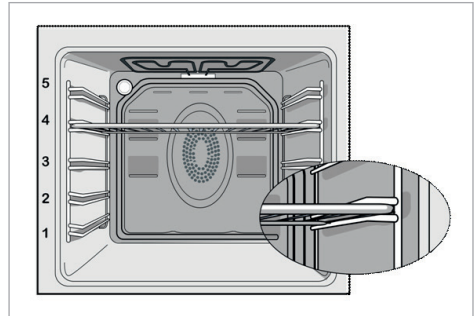

### **Rack positions (for models with wire shelf)**

It is important to place the wire shelf onto the side rack correctly. Wire shelf must be inserted between the side racks as illustrated in the figure.

Do not let the wire shelf stand against the rear wall of the oven. Slide your wire shelf to the front section of the rack and settle it with the help of the door in order to obtain a good grill performance. (Varies depending on the product model.)



## Operating modes

All functions in your oven (including the main oven) are described in this section. The order of operating modes shown here may be different from the arrangement on your product.

### Oven lamp



The oven is not heated. Only the oven lamp is turned on. Possibly, the external cooling fan will also operate to avoid heating of the compartments.

### Top and bottom heating



Top and bottom heating are in operation. Food is heated simultaneously from the top and bottom. For example, it is suitable for cakes, pastries, or cakes and casseroles in baking moulds. Cook with one tray only.

### Bottom heating



Only bottom heating is in operation. It is suitable for pizza and for subsequent browning of food from the bottom.

### Operating with fan



The oven is not heated. Only the fan (in the rear wall) is in operation. Suitable for thawing frozen granular food slowly at room temperature and cooling down the cooked food.

### Fan heating



Warm air heated by the rear heater is evenly distributed throughout the oven rapidly by means of the fan. It is suitable for cooking your meals in different rack levels and preheating is not required in most cases. Suitable for cooking with multi trays.

### Grill



Small grill at the ceiling of the oven is in operation. Suitable for grilling.

- Put small or medium-sized portions in correct shelf position under the grill heater for grilling.
- Turn the food after half of the grilling time.

### Full grill



Large grill at the ceiling of the oven is in operation. It is suitable for grilling large amount of meat.

- Put big or medium-sized portions in correct rack position under the grill heater for grilling.
- Turn the food after half of the grilling time.

## Using the oven clock

**i** The oven clock only controls the bottom oven. It has no effect for the top oven.

### General warnings

**i** Maximum time that can be set for end of cooking is 5 hours 59 minutes.

Programme will be cancelled in case of power failure. You must reprogramme the oven.

**i** While making any adjustments, the relevant symbols flash on the display. Please wait a short time for the settings to be saved.

**i** If any cooking setting has been made, the time of the day cannot be adjusted.





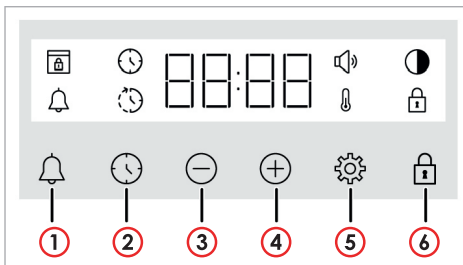



**i** If cooking time is set when cooking starts, the remaining time is displayed on the screen.

**i** In cases where cooking time or cooking end time is set; you can cancel automatically by touching the key  for a long time.



- ① Alarm key
- ② Time setting key
- ③ Decrease key
- ④ Increase key
- ⑤ Settings key
- ⑥ Key lock key



### Display symbols

-  : Cooking time symbol
-  : Cooking end time symbol\*
-  : Alarm symbol
-  : Brightness symbol
-  : Key lock symbol
-  : Temperature symbol
-  : Volume symbol
-  : Door lock symbol\*

\* It varies depending on the product model. It may not be available on your product.

### Cooking by setting the cooking time

You can have the oven turn off automatically at the end of the time by selecting the temperature and operating function specific to your food and setting the cooking time on the timer.

1. Select the operating function for cooking.
2. Touch  until the  symbol appears on the display for the cooking time.

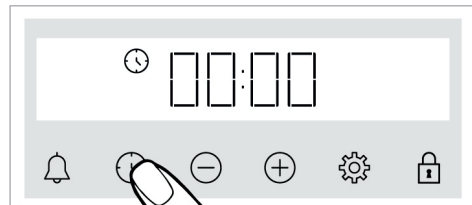

**i** After setting the operation function and temperature, you can set the cooking time for 30 minutes by touching the ⊕ key directly for quick setting of the cooking time and change the time with the ⊕ ⊖ keys.

3. Set the cooking time with the ⊕ ⊖ keys.

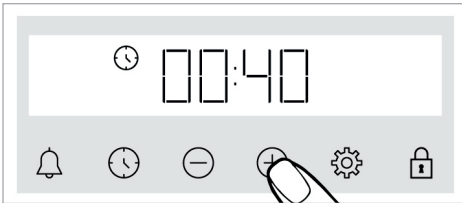

**i** The cooking time increases by 1 minute in the first 15 minutes, after 15 minutes it increases by 5 minutes.

4. Put your food in the oven and set the temperature with the temperature knob.

» Your oven will start operating immediately at the selected function and temperature. The set cooking time starts to count down and 🔔 appears on the display. When the temperature inside the oven reaches the set temperature, the 🔒 symbol disappears.

5. After the set cooking time is completed, on the screen, “End” appears, the 🕒 symbol flashes and the timer beeps.

6. The warning sounds for two minutes. Press any key to stop the warning. The warning stops and the time of day appears on the screen.

**To set the cooking end time to a later time; (It varies depending on the product model. It may not be available on your product.)**

By selecting the temperature and operating function specific to your meal, you can set the cooking time and the cooking end time to a later time, allowing the oven to start and turn off automatically.

1. Select the operating function for cooking.

2. Touch 🕒 until the 🕒 symbol appears on the display for the cooking time.

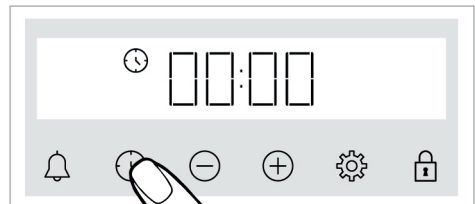

**i** After setting the operation function and temperature, you can set the cooking time for 30 minutes by touching the ⊕ key directly for quick setting of the cooking time and change the time with the ⊕ ⊖ keys.

3. Set the cooking time with the ⊕ ⊖ keys.

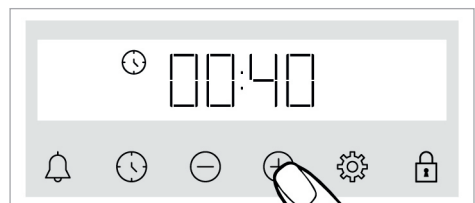

**i** The cooking time increases by 1 minute in the first 15 minutes, after 15 minutes it increases by 5 minutes.

- » After the cooking time has been set, the ⌚ symbol is constantly displayed on the screen.
- 4. Touch ⌚ until the ⌚ symbol appears on the display for the cooking end time.



- 3. Set the cooking end time with the + - keys.

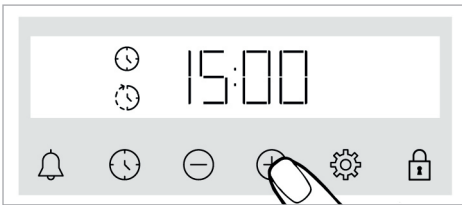

- » After the cooking end time is set, the ⌚ symbol and the ⌚ symbol with the time period symbol will appear constantly on the display. As soon as cooking starts, the ⌚ symbol disappears.
- 6. Put your food in the oven and set the temperature with the temperature knob.
- » **The oven time calculates the time to start cooking by subtracting the cooking time from the cooking end time you set.**

When the cooking start time comes, the selected function is activated and the oven heats up to the set temperature. The set cooking time starts to count down and 🔔 appears on the display. When the temperature inside the oven reaches the set temperature, the 🔔 symbol disappears.

- 7. After the set cooking time is completed, on the screen, “End” appears, the ⌚ symbol flashes and the timer beeps.
- 8. The warning sounds for two minutes. Press any key to stop the warning. The warning stops and the time of day appears on the screen.

**i** If any key is pressed at the end of the audible warning, the oven will start operating again. To prevent the oven from operating again at the end of the warning, get the temperature knob and function knob to the “0” position (off) and turn the oven off.



## Settings

### Activating key lock

You can prevent control unit from being intervened with by activating the key lock function.

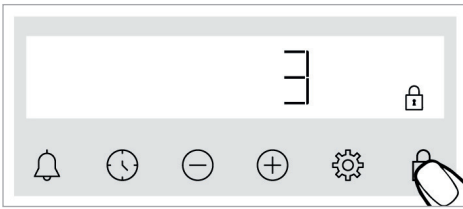
- 1. Touch 🔒 until the 🔒 symbol appears on the display.





» The  symbol appears and the 3-2-1 countdown begins on the display. When the countdown is over, the key lock is activated. When any key is touched when the key lock is set, the timer sounds an audible signal and the  symbol flashes.

 If you stop touching the lock key before the countdown ends, the key lock will not be activated.

 Timer keys cannot be used when key lock is on. The key lock will not be cancelled in case of power failure.

### Deactivating the key lock

1. Touch  until the  symbol disappears on the display.

» The  symbol disappears and the key lock is disabled on the display.



### Setting the alarm

You can also use the timer of the product for any warning or reminder other than cooking.

The alarm clock has no effect on the oven operating functions. Used for warning purposes.

For example, you can use the alarm clock when you want to turn the food in the oven at a certain time. As soon as the time you set has expired, the clock gives you an audible warning.

 Maximum alarm time can be 23 hours and 59 minutes.

1. Touch  until the  symbol appears on the display.

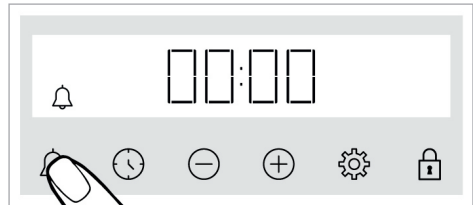

2. Set the alarm time with the   keys.







» After setting the alarm time, the  symbol remains lit and the alarm time starts the countdown the display. If the alarm time and cooking time are set at the same time, the shorter time is displayed on the display.

3. After the alarm time is completed, the  symbol starts flashing and gives you an audible warning.

## Turning off the alarm

- At the end of the alarm period, the warning audio for two minutes. Touch any key to stop the warning audio.
- » The warning audio stops and the time of day appears on the display.



## If you want to cancel the alarm

- Touch  until the  symbol appears on the display to reset the alarm time. Touch the  key until it shows "00:00".
-  you can also cancel the alarm by long pressing the key.

## Changing the volume level

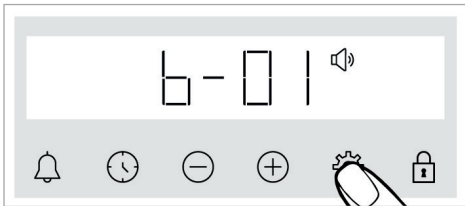
- Touch the  key until  symbol appears on the display.



- Set the desired level with the   keys. ("b-1"-"b-2"-"b-3").

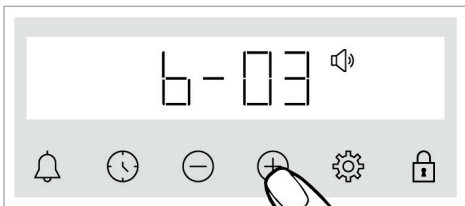

- Touch the  key for confirmation, or the setting is activated shortly without touching a key.

## Setting the display brightness

- Touch the  key until  symbol appears on the display.

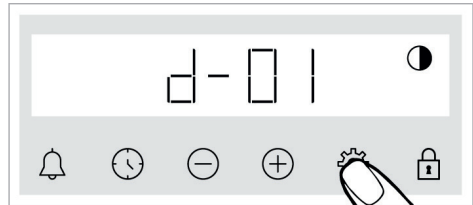



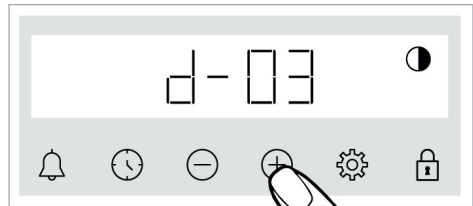

- Set the desired brightness with the   keys. (d-01-d-02-d-03).



- » Touch the  key for confirmation, or the setting is activated shortly without touching a key.

## Changing the time of day

On your oven; to change the time of day that you have previously set.

- Touch  until the  symbol appears on the display.
- Set the time of day by touching the   keys.

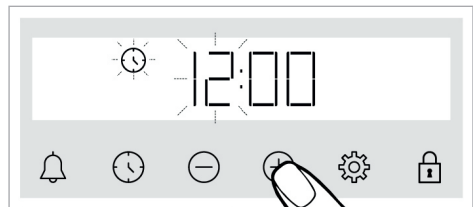

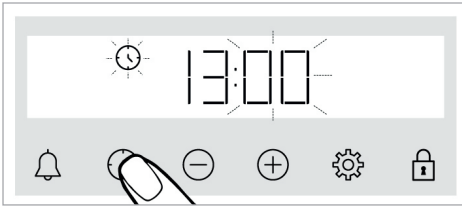

3. Touch  or  key to activate the minute field.

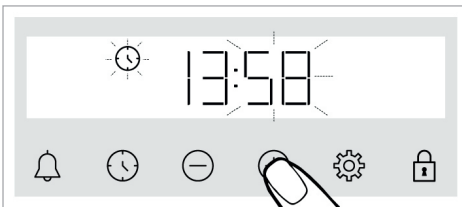

4. Set the minute of day by touching the   keys.



5. Confirm the setting by touching the  or  key.

















» The time of day is set and the  symbol disappears on the screen.

## Cooking times table













**i** The timings in this chart are meant as a guide. Timings may vary due to temperature of food, thickness, type and your own preference of cooking.

### Baking and roasting

**i** 1st rack of the oven is the bottom rack.

Dish	Cooking level number	Accessory to use	Operating mode	Rack position	Temperature (°C)	Cooking time (approx. in min.)
Cakes in tray	One level	Standard tray*		3	180	25 - 30
Cakes in mould	One level	Cake mould on wire grill**		2	180	40 - 50
Small cakes***	One level	Standard tray*		3	150	30 - 40
	2 levels	1-Pastry tray* 3-Standard tray*		1 - 3	150	35 - 50
	3 levels	1-Standard tray* 3-Pastry tray* 5-Deep tray*		1 - 3 - 5	150	35 - 50
Sponge cake***	One level	Round springform pan with a diameter of 26cm on wire grill**		2	150	30 - 40
	2 levels	1-Round springform pan with a diameter of 26 cm on wire grill**  4-Round springform pan with a diameter of 26 cm on pastry tray**		1 - 4	150	35 - 45
Cookies	One level	Pastry tray*		3	180	25 - 30
	2 levels	1-Pastry tray* 3-Standard tray*		1 - 3	180	30 - 40
	3 levels	1-Pastry tray* 3-Standard tray* 5-Deep tray*		1 - 3 - 5	180	35 - 45
Dough pastry	One level	Standard tray*		3	200	30 - 40
	2 levels	1-Pastry tray* 5-Standard tray*		1 - 5	200	45 - 55
	3 levels	1-Pastry tray* 3-Standard tray* 5-Deep tray*		1 - 3 - 5	200	55 - 65
Rich pastry	One level	Standard tray*		3	200	25 - 35
	2 levels	1-Pastry tray* 3-Standard tray*		1 - 3	200	35 - 45
	3 levels	1-Pastry tray* 3-Standard tray* 5-Deep tray*		1 - 3 - 5	190	45 - 55



Dish	Cooking level number	Accessory to use	Operating mode	Rack position	Temperature (°C)	Cooking time (approx. in min.)
Shortbread***	One level	Standard tray*		3	140	20 - 30
	2 levels	1-Standard tray* 3-Pastry tray*		1 - 3	140	20 - 30
	3 levels	1-Pastry tray* 3-Standard tray* 5-Deep tray*		1 - 3 - 5	140	22 - 35
Apple pie***	One level	Round black metal dish with a diameter of 20 cm on wire grill**		2	170	50 - 60
	2 levels	1-Round black metal dish with a diameter of 20 cm on wire grill**  4-Round black metal dish with a diameter of 20 cm on pastry tray**		1 - 4	170	50 - 60
Leaven	One level	Standard tray*		2	200	35 - 45
Lasagna	One level	Glass/metal rectangular pan on wire grill**		3	200	30 - 40
Beef steak (whole) / roast	One level	Standard tray*		3	25 min. 250/max. then, 180 - 190	100 - 120
Leg of lamb (casserole)	One level	Standard tray*		3	25 min. 220 then, 180 - 190	70 - 90
Roasted chicken (1,8-2kg)	One level	Standard tray*		2	15 min. 250/max. then, 190	70 - 90
Turkey (5.5kg)	One level	Standard tray*		1	25 min. 250/max. then, 190	150 - 210
Fish	One level	Standard tray*		3	200	20 - 30

It is suggested to perform preheating for all foods.

\* These accessories may not be supplied with the product.

\*\* These accessories are not supplied with the product. They are commercially available accessories.

\*\*\* **Test Foods** - Foods in this cooking table are prepared according to the EN 60350-1 standard to facilitate testing of the product for control institutes.

## Tips for baking cake

- If the cake is too dry, increase the temperature by 10°C and decrease the cooking time.
- If the cake is wet, use less liquid or lower the temperature by 10°C.
- If the cake is too dark on top, place it on a lower rack, lower the temperature and increase the cooking time.
- If cooked well on the inside but sticky on the outside use less liquid, lower the temperature and increase the cooking time.

## Tips for baking pastry

- If the pastry is too dry, increase the temperature by 10°C and decrease the cooking time. Dampen the layers of dough with a sauce composed of milk, oil, egg and yoghurt.
- If the pastry takes too long to bake, pay care that the thickness of the pastry you have prepared does not exceed the depth of the tray.
- If the upper side of the pastry gets browned, but the lower part is not cooked, make sure that the amount of sauce you have used for the pastry is not too much at the bottom of the tray. Try to scatter the sauce equally between the dough layers and on the top of pastry for an even browning.
- **i** Cook the pastry in accordance with the mode and temperature given in the cooking table. If the bottom part is still not browned enough, place it on one lower rack next time.

## Tips for cooking vegetables

- If the vegetable dish runs out of juice and gets too dry, cook it in a pan with a lid instead of a tray. Closed vessels will preserve the juice of the dish.
- If a vegetable dish does not get cooked, boil the vegetables beforehand or prepare them like canned food and put in the oven.

## How to operate the top oven

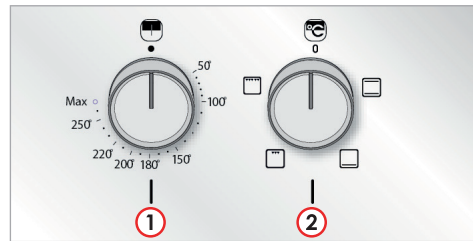

### ① Top oven thermostat knob

### ② Top oven function knob

Operating modes of the electric oven are selected with Function knob. Temperature setting is made with Thermostat knob.

All oven functions are turned off by turning the relevant knob to 'OFF' (upper) position.

## Select temperature and operating mode

1. Set the Thermostat knob to the desired temperature.
2. Set the Function knob to the desired operating mode.
  - » Oven heats up to the adjusted temperature and maintains it. During heating and cooling, thermostat light turns on.

## Switching off the electric oven

Turn the Function knob and thermostat knob to 'OFF' (upper) position.

**i** While cooking is in progress, when the electricity is cut and comes back again, the top oven continues to operate. In case of any power failure, make sure to turn off the oven.

**i** Maximum load capacity of oven tray: 4kg (8.8lb).

**i** 1st rack of the oven is the bottom rack.

- Do not place cookware with rough bases on the oven door.
- Ensure that there is at least 25mm space at top of oven when cooking larger foods or using taller cookware.

## Cooking times table

**i** The timings in this chart are meant as a guide. Timings may vary due to temperature of food, thickness, type and your own preference of cooking.

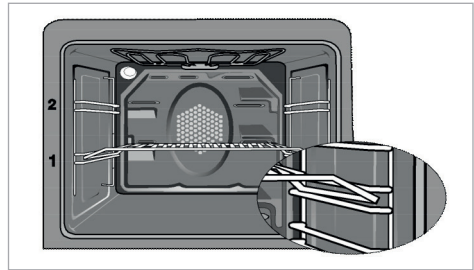

## Baking and roasting

Dish	Cooking level number	Accessory to use	Operating mode	Rack position	Temperature (°C)	Cooking time (approx. in min.)
Cakes in tray	One level	Standard tray*		1	180	40 - 50
Small cakes	One level	Standard tray*		1	160	35 - 45
Cookies	One level	Standard tray*		1	180	30 - 40
Dough pastry	One level	Standard tray*		1	200	30 - 40
Rich pastry	One level	Standard tray*		1	200	25 - 35
Leaven	One level	Standard tray*		1	200	35 - 45
Pizza	One level	Standard tray*		1	200 - 220	15 - 20
Beef steak (whole) / roast	One level	Standard tray*		1	25 min. 220/max. then, 180 - 190	100 - 120
Leg of lamb (casserole)	One level	Standard tray*		1	25 min. 220 then, 180 - 190	70 - 90
Roasted chicken (sliced)	One level	Standard tray*		1	15 min. 220/max. then, 190	65 - 80
Fish	One level	Standard tray*		2	200	20 - 30

\* These accessories may not be supplied with the product.

## How to operate the top grill

 Close oven door during grilling.  
Hot surfaces may cause burns!

### Switching on the grill

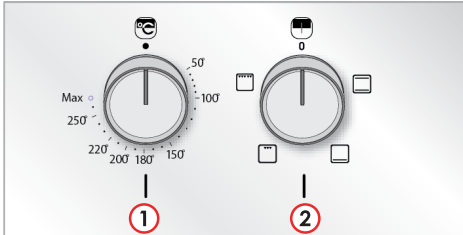

#### ① Top oven thermostat knob

#### ② Top oven function knob

1. Set the Function knob to Grill symbol.
  2. Set the temperature to maximum level.
  3. If required, perform a preheating of about 5 minutes.
- » Thermostat (temperature) light turns on.

### Switching off the grill

1. Turn the Grill control knob to 'OFF' (upper) position.

 While cooking is in progress, when the electricity is cut and comes back again, the top oven continues to operate. In case of any power failure, make sure to turn off the oven.

- Put big or medium-sized portions in correct rack position under the grill heater for grilling.
- For food only whose top is required to be roasted, grill the food either by placing onto the wire grill in the tray or by placing the tray onto the floor of grilling compartment.

- Food and plates placed onto the floor of grill compartment will get heated when the main oven is in use. Do not switch on the grill compartment when using it for storing food.

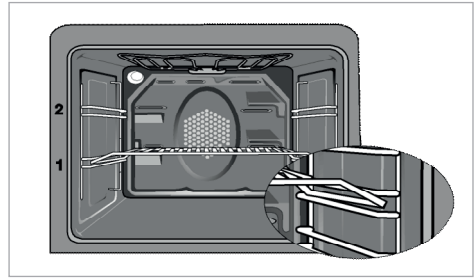

-  Foods that are not suitable for grilling carry the risk of fire. Only grill food which is suitable for intensive grilling heat. Do not place the food too far in the back of the grill. This is the hottest area and fatty food may catch fire.

## Top oven cooking times table for grilling with electric grill



1st rack of the oven is the bottom rack.

Food	Insertion level	Recommended temperature (°C)	Cooking time (approx. in min.)
Fish	1	Max	20 - 25 <sup>#</sup>
Sliced chicken	1	Max	25 - 35
Lamb chops	1	Max	20 - 25
Roast beef	1	Max	25 - 30 <sup>#</sup>
Veal chops	1	Max	25 - 30 <sup>#</sup>
Toast bread*	1	Max	1 - 3

<sup>#</sup> Depending on thickness.

\* Preheat for 5 minutes.

## 7. Maintenance and care

### General cleaning information

---

#### General warnings

- Wait for the product to cool before cleaning the product. Hot surfaces may cause burns!
- Do not apply the detergents directly on the hot surfaces. This may cause permanent stains.
- The appliance shall be thoroughly cleaned and dried after each operation. Thus, food residues shall be easily cleaned and these residues shall be prevented from burning when the appliance is used again later. Thus, the service life of the appliance extends and frequently faced problems are decreased.
- Do not use steam cleaning products for cleaning.
- Some detergents or cleaning agents may damage the surface. Do not use abrasive detergents, cleaning powders, cleaning creams, descalers or sharp objects during cleaning.
- There is no need for a special cleaning agent for cleaning after each use. Clean the appliance using dish soap, warm water and a soft cloth or sponge and dry with a dry microfibre cloth.
- Be sure to completely wipe off any remaining liquid after

cleaning and immediately clean any food splashing around during cooking.

- Do not wash any component of your appliance in a dishwasher.

#### Inox and stainless surfaces

- Do not use acid or chlorine-containing cleaning agents to clean stainless or inox surfaces and handles.
- Stainless or inox surface may change colour in time. This is normal. After each operation, clean with a detergent suitable for the stainless or inox surface.
- Clean with a soft soapy cloth and liquid (non-scratching) detergent suitable for inox surfaces, taking care to wipe in one direction.
- Remove lime, oil, starch, milk and protein stains on the inox-stainless and glass surfaces immediately without waiting. Stains may rust under long periods of time.

#### Enamelled surfaces

- After each use, clean the enamel surfaces using dishwashing detergent, warm water and a soft cloth or sponge and dry them with a dry cloth.
- If your product has an easy steam cleaning function, you can make easy steam cleaning for light non-permanent dirt.

- You may use the Quick&Shine cleaning agents for the oven interiors and grills and non-scratching scouring wire, used on enamelled surfaces and recommended by the Authorised Service, for persistent stains. Do not use an external oven cleaner.
- The oven must cool down for cleaning in the cooking area. Cleaning on hot surfaces shall create both fire hazard and damage with enamel surface.
- If there is residual detergent after cleaning, wipe it with cold water and dry with a clean and dry microfibre cloth. Residual detergent residue may damage the glass surface next time.
- Under no circumstances should the dried-up residue on the glass surface be cleaned off with serrated knives, wire wool or similar scratching tools.
- You can remove the calcium stains (yellow stains) on the glass surface with the commercially available descaling agent, with a descaling agent such as vinegar or lemon juice.

### **Catalytic surfaces**

- The side walls in the cooking area can only be covered with enamel or catalytic walls. It varies by model.
- The catalytic walls have a light matte and porous surface. The catalytic walls of the oven should not be cleaned.
- Catalytic surfaces absorb oil thanks to its porous structure and start to shine when the surface is saturated with oil, in this case it is recommended to replace the parts.

### **Glass surfaces**

- When cleaning glass surfaces, do not use hard metal scrapers and abrasive cleaning materials. They can damage the glass surface.
- Clean the appliance using dishwashing detergent, warm water and a microfibre cloth specific for glass surfaces and dry it with a dry microfibre cloth.
- If the surface is heavily soiled, apply the cleaning agent on the stain with a sponge and wait a long time for it to work properly. Then clean the glass surface with a wet cloth.
- Discolourations and stains on the glass surface are normal and not defects.

### **Plastic parts and painted surfaces**

- Clean plastic parts and painted surfaces using dishwashing detergent, warm water and a soft cloth or sponge and dry them with a dry cloth.
- Do not use hard metal scrapers and abrasive cleaners. It may damage the surfaces.
- Ensure that the joints of the components of the appliance are not left as damp and with detergent. Otherwise, corrosion may occur on these joints.

## Cleaning the accessories

Unless otherwise stated in the user manual, do not wash the product accessories in the dishwasher.

## Cleaning the control panel

- When cleaning the panels with knob control, wipe the panel and knobs with a damp soft cloth and dry with a dry cloth. Do not remove the knobs and gaskets underneath to clean the control panel. The control panel and knobs may be damaged.
- While cleaning the inox panels with knob control, do not use inox cleaning agents around the knobs. The indicators around the knobs may be deleted.
- Clean the touch control panels with a damp soft cloth and dry with a dry cloth. If your product has a key lock feature, set the key lock before performing control panel cleaning. Otherwise, incorrect detection may occur on the keys.

## Cleaning the inside of the oven (cooking area)

Follow the cleaning steps described in the “General cleaning information” section according to the surface types in your oven.

### Cleaning the side walls of the oven

The side walls in the cooking area can only be covered with enamel

or catalytic walls. It varies by model. If there is a catalytic wall, refer to the “Catalytic walls” section for information. If your product is a side rack model, remove the side racks before cleaning your side walls. Then complete the cleaning as described in the “General cleaning information” section according to the side wall surface type.

### To remove the side racks:

1. Remove the front section of the side rack by pulling it in the opposite direction of the side wall.
2. Remove the side rack completely by pulling it towards you.

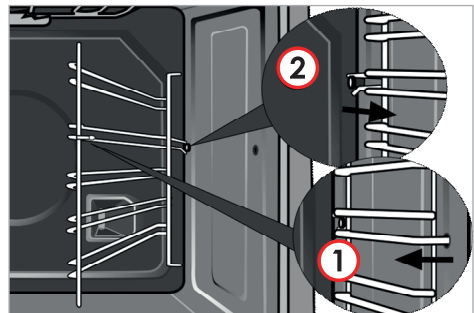

## Cleaning the oven door

**i** Do not use harsh abrasive cleaners, metal scrapers, wire wool or bleach materials to clean the oven door and glass.

**i** The oven door inner glass is covered with an easy-to-clean material. Do not use abrasive cleaning agents, hard metal scrapers, wire wool or bleach materials such as bleach.



You can remove your oven door and door glasses to clean them. How to remove the doors and windows is explained in the sections “Removing the oven door” and “Removing the inner glasses of the door”. After removing the door inner glasses, clean them using a dishwashing detergent, warm water and a soft cloth or sponge and dry them with a dry cloth. Wipe the glass with vinegar and then rinse it against lime residues that may occur on the oven glass.

### Removing the oven door

1. Open the front door **①**.
2. Open the clips at the hinge housing **②** on the right and left hand sides of the front door by pressing them down as illustrated in the figure.

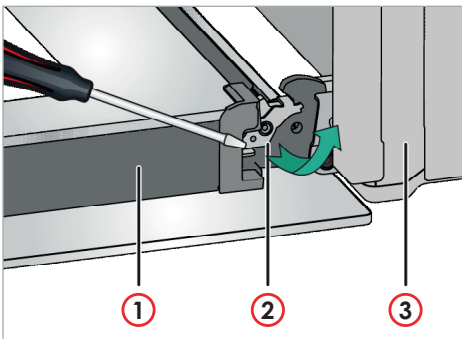

- ① Door**
- ② Hinge lock (closed position)**
- ③ Oven**

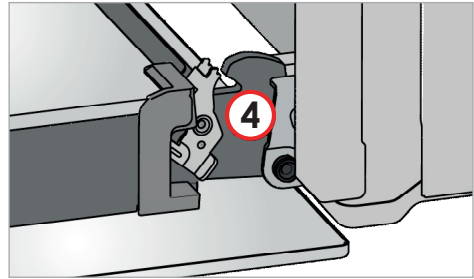

### **④ Hinge lock (open position)**

3. Move the front door to half-way.

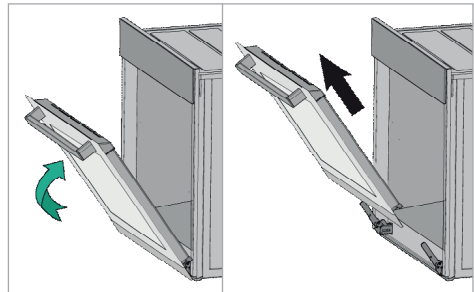

4. Remove the front door by pulling it upwards to release it from the right and left hinges.

**i** Steps carried out during removing process should be performed in reverse order to install the door. Do not forget to close the clips at the hinge housing when reinstalling the door.

## Removing the inner glass door

The entire inner glass panel of the oven door can be removed for cleaning.

1. Open the oven door.

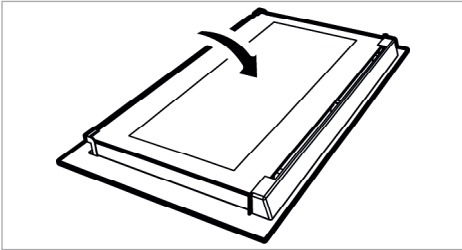

2. Pull towards yourself and remove the plastic part installed to upper section of the front door.

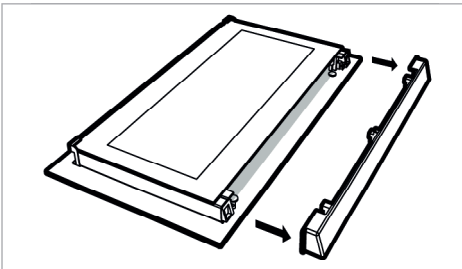

3. As illustrated in figure (below), raise the innermost glass panel **1** slightly in direction **A** and pull it out in direction **B**.

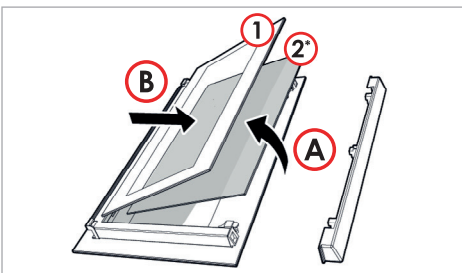

- 1** Innermost glass panel
- 2** Inner glass panel (This may not exist on your product.)

4. If your product is equipped with an inner glass panel; repeat the same procedure to remove the inner glass panel **2**.
5. The first step to regroup the door is reinstalling inner glass panel **2**. Place the chamfered corner of the glass panel so that it will rest in the chamfered corner of the plastic slot. (If your product is equipped with an inner glass panel). Inner glass panel **2** must be installed into the plastic slot close the innermost glass panel **1**.
6. When installing the innermost glass panel **1**, make sure that the printed side of the panel faces towards the inner glass panel. It is important to seat lower corner of innermost glass panel **1** into the lower plastic slot.
7. Push the plastic part towards the frame until you hear a 'click'.

## Cleaning the oven lamp

In the event that the glass door of the oven lamp in the cooking area becomes dirty; clean using dishwashing detergent, warm water and a soft cloth or sponge and dry with a dry cloth. In case of oven lamp failure, you can replace the oven lamp by following the sections that follow.

## Replacing the oven lamp

### ⚠ General warnings

- To avoid the risk of an electric shock before replacing the oven lamp, disconnect the electrical connector and wait for the oven to cool. Hot surfaces may cause burns!
- The oven lamp is a special electric bulb resistant to 300°C. Oven lamps can be obtained from Authorised Services.
- The position of the lamp may differ from that is shown in the figure (below).
- The lamp used in this product is not suitable for use in the lighting of home rooms. The purpose of this lamp is to help the user see food products.
- The lamps used in this product must withstand extreme physical conditions such as temperatures above 50°C.

### If your oven has a round lamp

1. Disconnect the product from the electricity.
2. Remove the glass cover by turning it counterclockwise.

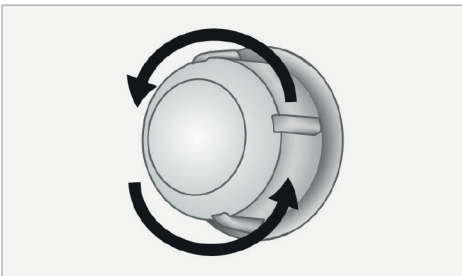

3. Pull it out as shown in the figure and replace it with a new one.

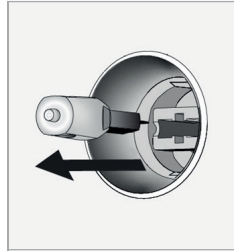

4. Refit the glass cover.

## 8. Troubleshooting

Consult the Authorised Service Agent or technician with license or the dealer where you have purchased the product if you cannot remedy the trouble although you have implemented the instructions in this section. Never attempt to repair a defective product yourself.

### Oven emits steam when it is in use

- It is normal that steam escapes during operation. » *This is not a fault.*

### Product emits metal noises while heating and cooling

- When the metal parts are heated, they may expand and cause noise.  
» *This is not a fault.*

### Product does not operate

- The mains fuse is defective or has tripped. » *Check fuses in the fuse box. If necessary, replace or reset them.*
- Product is not wired into the (grounded) socket. » *Check the electrical connection.*

### Oven light does not work

- Oven lamp is defective. » *Replace oven lamp.*
- Power is cut. » *Check if there is power. Check the fuses in the fuse box. If necessary, replace or reset the fuses.*

### Oven does not heat

- Might not be set to a certain cooking function and/or temperature. » *Set the oven to a certain cooking function and/or temperature.*
- In models equipped with a timer, the timer is not adjusted. » *Adjust the time. (In products with microwave oven, timer controls only microwave oven.)*
- Power is cut. » *Check if there is power. Check the fuses in the fuse box. If necessary, replace or reset the fuses.*

### (In models with timer) Clock display is blinking or clock symbol is on

- A previous power outage has occurred. » *Adjust the time / Switch of the product and switch it on again.*

## 9. Your guarantee

### Product Guarantee Details (UK and Republic of Ireland only)

**Your appliance has the benefit of a comprehensive manufacturer's guarantee which covers the cost of breakdown repairs. (Details of which are shown on your Proof of Purchase Document).**

- Any claim during the period of the guarantee **MUST BE ACCOMPANIED BY THE PROOF OF PURCHASE.**
- The product must be correctly installed and operated in accordance with the manufacturer's instructions and used for normal domestic purposes.
- This guarantee does not cover accidental damage, misuse or alterations which are likely to affect the product.
- The guarantee is invalid if the product is tampered with, or repaired by any unauthorised person. *(The guarantee in no way affects your statutory or legal rights).*

### What to do if you need to report a problem

Please ensure you have ready:

- The product's model and serial numbers.
- Howdens Proof of Purchase Document.
- Your full contact details.

**Call the Depot number on your Proof of Purchase Document supplied with the product/kitchen.**

or

**Call the LAMONA Service Line on:**

**Within the UK: 0344 460 0006**

**Within Republic of Ireland: 01525 5703**

- Product installed within a domestic kitchen or a non-domestic kitchen where 8 or fewer people are using the appliance.

Where to find model and serial number on your appliance.	Open door on panel just below door seal.
--	--

**Spare Parts availability – 10 years**

**Only fit Genuine Spare Parts**

**[www.lamonaspares.co.uk](http://www.lamonaspares.co.uk)** (UK only)





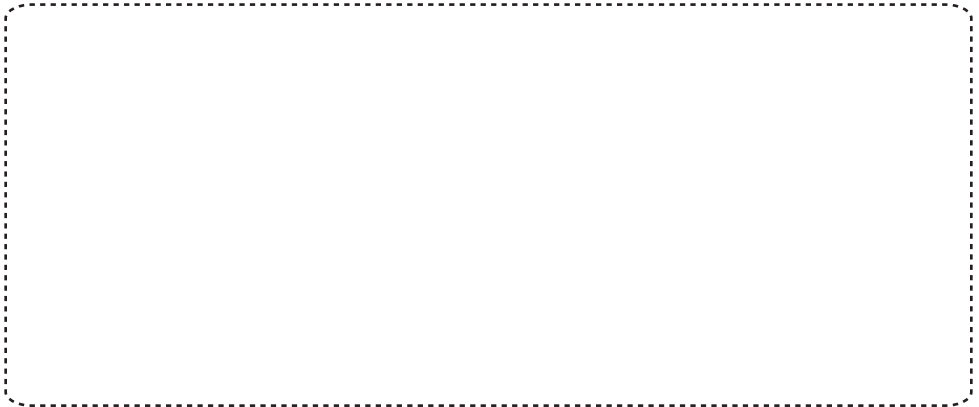

Product serial number  
(Place sticker here)

# LAMONA

at the heart of the kitchen



FR

Cet appareil  
se recycle

REPRISE  
À LA LIVRAISON



OU

À DÉPOSER  
EN MAGASIN



OU

À DÉPOSER  
EN DÉCHÈTERIE



Points de collecte sur [www.quefairedemesdechets.fr](http://www.quefairedemesdechets.fr)  
Privilégiez la réparation ou le don de votre appareil!

Howden Joinery Ltd, Thorpe Road, Howden, East Yorkshire, DN14 7PA

Imported in EU by: Houdan Cuisines SAS, Z.A. du Bois Rigault Nord,  
1Rue Calmette, 62880 Vendin-le-Vieil, Cedex, France.

Product information correct at the time of publication in March 2022.  
The company has a policy of continuous product development and  
reserves the right to change any products and specifications given in  
this manual. Subject to the Terms and Conditions of Trading, a copy of  
the Howdens Terms and Conditions is available upon request.

Copyright © 2022 Howden Joinery Ltd. All rights reserved.

385.4429.61/R.AB/12.06.2023  
7724086787