

EN Operating and installation instructions QVAC

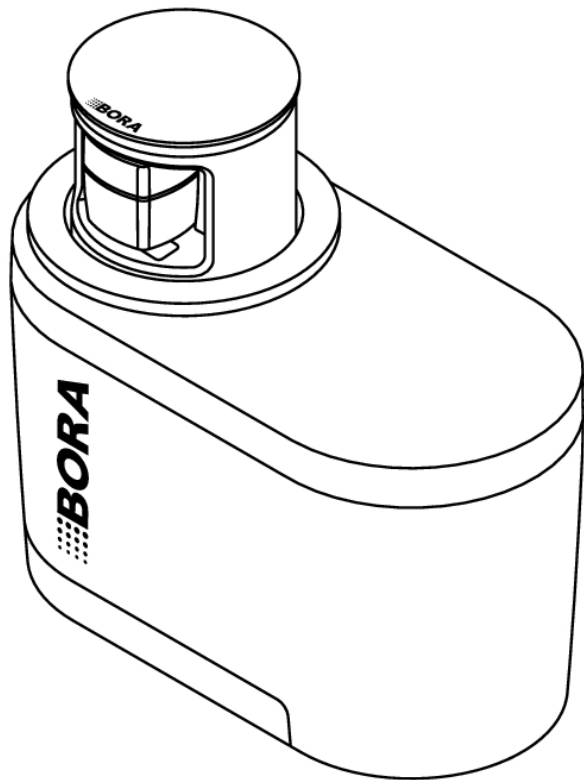

Contents

1	General information	3
1.1	Validity of the operating and installation instructions	3
1.2	Liability	3
1.3	Product conformity	3
1.4	Presentation of information	3
1.4.1	Safety and warning instructions	3
1.4.2	Figures.....	3
2	Safety	4
2.1	Intended use	4
2.2	People with limited abilities	4
2.3	General safety instructions	4
2.4	Safety information for installation	5
2.5	Safety instructions – operation.....	5
2.6	Safety instructions – cleaning and maintenance	6
3	Technical data	7
3.1	QVac appliance dimensions	7
4	Appliance description	8
4.1	System description	8
5	Functions and operation	9
5.1	How to use the appliance	9
5.2	How to use the vacuum bags	9
5.3	How to use the vacuum boxes	9
5.4	How to use the vacuum seal (power setting)	10
5.5	How to use the marinating ring (for fast marinating)	10
6	Cleaning and maintenance	11
6.1	How to clean vacuum bags	11
6.2	How to clean the vacuum boxes	11
6.3	How to clean the moisture trap	11
6.4	How to clean and replace the vacuum hose.....	11
6.5	How to remove water from the appliance	12
7	Troubleshooting	13
8	Installation	14
8.1	Scope of delivery	14
8.1.1	Components	14
8.2	Assembly instructions	14
8.2.1	Installation options	14
8.2.2	How to prepare the worktop.....	14
8.3	Worktop cut-out	14
8.3.1	Cut-out dimensions	15
8.4	Installing the appliance	15
8.4.1	Preparing for installation	15
8.4.2	Standard installation.....	16
8.5	Initial operation	17
8.6	Sealing the appliances.....	17
8.7	Handover to user	17
9	Decommissioning, disassembly and disposal	18
9.1	Decommissioning	18
9.2	Disassembly	18
9.3	Environmentally-friendly disposal	18
9.3.1	Disposal of transport packaging	18
9.3.2	Disposal of the old appliance.....	18

10	Warranty, technical service, spare parts, accessories	19
10.1	BORA manufacturer's warranty	19
10.1.1	Warranty extension.....	19
10.2	Service.....	19
10.3	Full replacement of the appliance.....	19
10.4	Accessories	19

1 General information

These instructions contain important information to protect you from injury and prevent damage to the appliance. Please read these instructions carefully before installing or using the appliance for the first time.

Other documents apply alongside these instructions. Please by all means adhere to all documents that form part of the scope of delivery.

Assembly, installation and commissioning must always occur in line with national laws, regulations and standards.

All safety and warning information as well as the handling instructions in the accompanying documents must be observed.

Please keep these instructions in a safe place and pass them on to the next owner where applicable.

1.1 Validity of the operating and installation instructions

These instructions apply to several appliance versions. It is therefore possible that some of the features described do not apply to your appliance. The details of the figures contained herein may differ from some appliance versions and are to be understood as schematic diagrams.

1.2 Liability

. BORA Holding GmbH, BORA Vertriebs GmbH & Co KG, BORA APAC Pty Ltd and BORA Lüftungstechnik GmbH – hereinafter referred to as BORA – do not assume any liability for damage arising from disregard for or non-adherence to the documents included in the scope of delivery!

Furthermore, BORA shall not be held liable for damage caused by improper installation or failure to observe the safety and warning information!

1.3 Product conformity

Directives

The appliances meet the following EU/EC directives:

- 2014/30/EU EMC Directive
- 2014/35/EU Low Voltage Directive
- 2009/125/EC Ecodesign Directive
- 2011/65/EU RoHS Directive

1.4 Presentation of information

We use standard formatting, numbering, symbols, safety instructions, terms and abbreviations so that you can work quickly and safely when using this manual. The article described in these instructions is hereinafter also referred to as an appliance.

Instructions are indicated with an arrow.

▶ Always follow all instructions in the prescribed order.

Enumerations are indicated with a bullet point at the start of the line:

- Enumeration 1
- Enumeration 2

 Information notes point to special features that must be taken into account.



1.4.1 Safety and warning instructions

The safety and warning instructions in this manual are emphasised with symbols and signal words. Safety and warning instructions are structured as follows:

 DANGER
Type and source of danger
Results of non-compliance
▶ Measures to minimise risk

Please note:

- warning symbols draw attention to a high risk of injury.
- The signal word indicates the severity of that risk.

Warning symbol	Signal word	Risk
	Danger	Indicates an immediate, hazardous situation which causes death or serious injury if not respected.
	Warning	Indicates a potentially hazardous situation which can cause death or serious injury if not respected.
	Caution	Indicates a potentially hazardous situation which can cause death or serious injury if not respected.
	Note	Indicates a potentially hazardous situation which can cause property damage if not respected.

Tab. 1.1 Meaning of the warning symbols and signal words

1.4.2 Figures

All measurements are provided in millimetres.

2 Safety

The appliance complies with the stipulated safety requirements. The user is responsible for the safe use of the appliance, cleaning and maintenance. Improper use can lead to personal injury and damage to property.

2.1 Intended use

This appliance is only intended for vacuum sealing food in the containers and bags provided by BORA. The built-in vacuum sealer is only intended for use in private households.

This appliance is not intended for:

- professional use (catering)
- outdoor use
- use in mobile installation sites such as motor vehicles, ships or aeroplanes
- use at altitudes of over 2000 m (metres above sea level)
- operation if installed in unsuitable, technically incorrect conditions

Any other use or any use that goes beyond that which is described here is classed as unintended.

If the QVac built-in vacuum sealer is used as a freestanding appliance (that is, not built in), this is considered to be technically incorrect usage. Furthermore, this may lead to impaired performance as the opening through which the air is suctioned is on the bottom of the appliance.

- i** BORA does not assume any liability for damages caused by incorrect installation, improper use or incorrect operation.

All misuse is prohibited!

2.2 People with limited abilities

Children and people with reduced capacity

The appliance may only be used by children (at least 8 years of age) and people with reduced physical, sensory or mental capacities if they have been instructed on how to use the appliance safely and use the appliance under supervision. Children must not play with the appliance.

- i** Any work involving cleaning and maintenance must not be carried out by children unless they are supervised at all times while doing so.

People with reduced physical, sensory or mental capacities

The appliance can be used by people with reduced physical, sensory or mental capacities or a lack of experience and/or knowledge if they are supervised or have been instructed how to use the appliance safely and understand the resultant risks.

2.3 General safety instructions

⚠ DANGER

Risk of electric shock or injury from damaged surfaces or mechanical damage

The underlying electronics can be exposed or damaged due to fissures, fractures or cracks in appliance surfaces, particularly in the vicinity of the operating unit. This can cause an electric shock. Furthermore, a damaged surface or mechanical damage can cause injuries.

- ▶ Do not touch the damaged surface.
- ▶ In the event of any cracks, fissures, fractures or mechanical damage, switch the appliance off immediately.
- ▶ Safely disconnect the appliance from the power supply.
- ▶ Do not try to repair any damage to the appliance yourself.
- ▶ Contact the BORA Service Team.

⚠ DANGER

Packaging components are a choking hazard

Packaging components (e.g. film, polystyrene) can be life-threatening for children.

- ▶ Store all packaging components out of reach of children.
- ▶ Dispose of the packaging properly and immediately.

⚠ WARNING

Risk of injury or damage due to incorrect components or unauthorised modifications

Incorrect components can lead to personal injury or damage to the appliance. Modifications, additions or alterations to the appliance can lead to safety risks.

- ▶ Only use original components.
- ▶ Do not make any modifications, additions or alterations to the appliance.

⚠ WARNING**Risk of injury from electric shock**

Incorrect handling of electrical components may lead to electric shock.

- ▶ Always unplug the device from the mains before carrying out any work.
- ▶ The plug must be easy to access so that the appliance can be quickly disconnected from the mains supply in an emergency. The plug must be kept outside of the appliance back area.
- ▶ Do not pull on the cable; instead, always grab the plug connector to disconnect the appliance from the mains supply.
- ▶ Pull out the mains plug in case of fault or shut off the fuse.
- ▶ Do not damage the power cord.
- ▶ Do not operate any appliances with faulty power cords.

PLEASE NOTE**Faults and errors**

Any faults or incorrect handling may cause malfunctions or damage the appliance.

- ▶ In the case of faults and errors, follow the instructions in the “Troubleshooting” chapter.
- ▶ In the event of any faults or errors that are not mentioned, switch the appliance off and contact BORA Service.

PLEASE NOTE**Appliance damage caused by pets**

Pets may damage the appliance or injure themselves.

- ▶ Keep pets away from the appliance.

2.4 Safety information for installation**⚠ DANGER****Risk of electric shock from damaged appliance**

A damaged appliance can cause an electric shock.

- ▶ Check the appliance for visible damage prior to installation.
- ▶ Do not install or connect any damaged appliances.
- ▶ Do not operate any damaged appliances.

⚠ DANGER**Risk of injury from incorrect assembly**

Failure to observe the installation instructions can lead to injury.

- ▶ The appliance may only be installed with the power disconnected.
- ▶ Only use the power supply unit provided.

PLEASE NOTE**Damage caused by improper installation**

Parts of the kitchen units must be adapted to be able to install and use the appliance.

- ▶ Have the appliance installed and connected by a qualified tradesperson.

2.5 Safety instructions – operation**⚠ DANGER****Risk from anaerobic bacteria**

When vacuum sealed, many foods pose a risk to health from anaerobic bacteria.

- ▶ Never vacuum seal fresh mushrooms, soft cheese, onions or garlic.
- ▶ To ensure safe use of the appliance, please read the section “Vacuum sealing and food safety” in these instructions.

⚠ WARNING**Risk of food poisoning**

Improperly stored food may spoil. Vacuum sealing is not a substitute for preservation.

- ▶ Preserve perishable foods by chilling or freezing them, even when vacuum sealed.
- ▶ Do not re-freeze thawed/defrosted food.

⚠ WARNING**Risk of injury from trapped fingers**

There is a risk of injury when pushing down the pop-up unit.

- ▶ Please mind your hands and fingers when operating the mechanism.

PLEASE NOTE**Appliance damage and malfunctions due to unsuitable, soiled or damaged accessories**

The appliance may be damaged or its function impaired through the use of unsuitable, soiled or damaged food containers, vacuum bags, vacuum boxes or other accessories.

- ▶ Only use original BORA accessories.
- ▶ Only use clean vacuum bags, vacuum boxes and other accessories.
- ▶ Do not use damaged, brittle or worn accessories.

PLEASE NOTE**Damage to accessories from improper use**

The accessories (e.g. containers or bags) are subject to a number of usage restrictions.

- ▶ Please observe the maximum temperature of 70 °C for containers and bags.
- ▶ Always allow food to cool to room temperature before filling containers or bags.
- ▶ Do not use the containers in the microwave.

2.6 Safety instructions – cleaning and maintenance

PLEASE NOTE**Appliance damage**

Appliance damage due to improper cleaning.

- ▶ Only use soft cleaning cloths and pH-neutral multi-purpose cleaning products.
- ▶ Never use steam cleaners, abrasive sponges, scouring pads or chemically aggressive cleaning agents (e.g. oven cleaner spray).
- ▶ Make sure that the cleaning agent does not contain any sand, soda, acids, lyes or chloride.

PLEASE NOTE**Appliance damage due to soiled appliances**

Dirt can lead to damage, restriction of functions, or bothersome odours. In the worst case scenario, this can become a hazard.

- ▶ Clean the appliance regularly.
- ▶ Remove dirt immediately.
- ▶ Please follow all instructions in the “Cleaning and Maintenance” chapter.

3 Technical data

Parameter	Value
Supply voltage	100-240 V
Frequency	50-60 Hz
Maximum power consumption	24 W
Connection cable length	2 m
Suction power	≈ 10 L/min
Maximum vacuum pressure	-90 kPa
Dimensions (width x depth x height)	239 × 124 × 142 mm
Weight (incl. accessories/ packaging)	3.48 kg
Surface material	stainless steel
Vacuum hose extension length	400 mm

Tab. 3.1 Technical data for QVac

3.1 QVac appliance dimensions

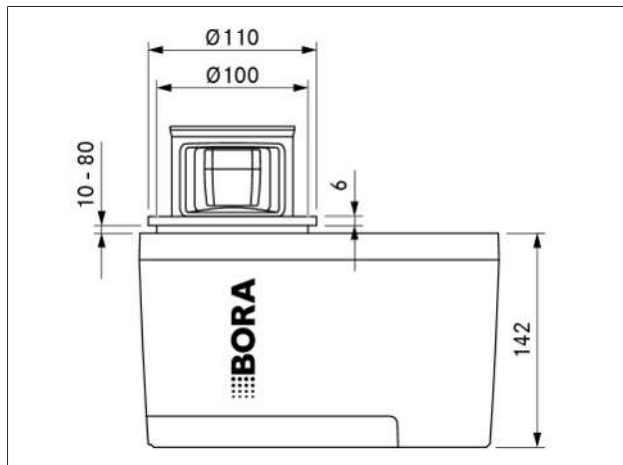

Fig. 3.1 QVac front view

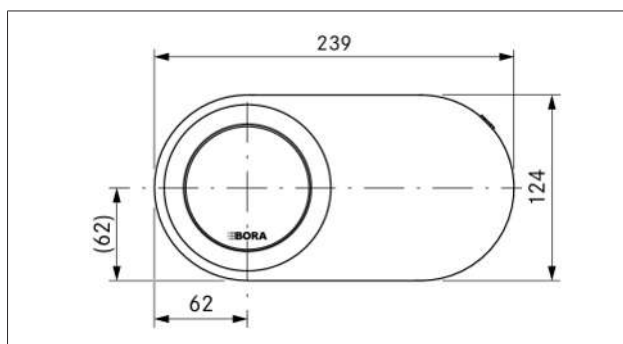

Fig. 3.2 QVac top view

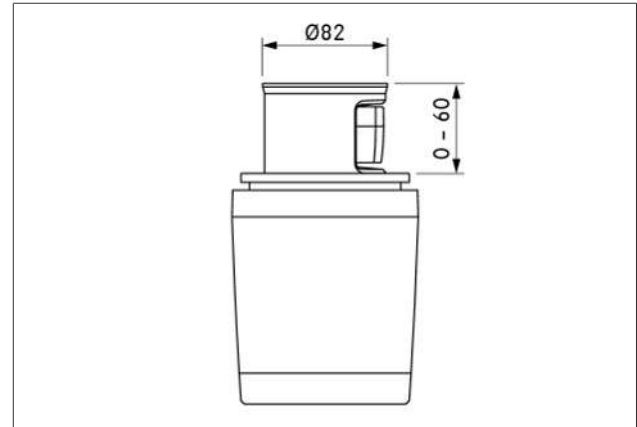

Fig. 3.3 QVac side view

4 Appliance description

4.1 System description

- Unique installation concept
- Super-fast marinating
- Make liquids keep for longer
- Pop-up unit with automatic on/off function
- Pull-out suction head (400 mm)
- 3 function buttons for different vacuum-sealing programmes
- Audiovisual operating concept

The transparent moisture trap with a built-in safety shut-down function protects the appliance if liquids enter through the valve during operation. These liquids are trapped and when the container is full, the appliance automatically switches off.

QVac built-in vacuum sealer

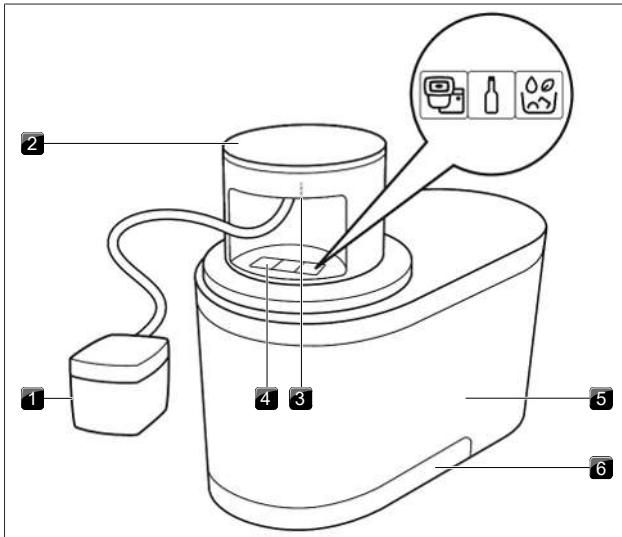

Fig. 4.1 Structure

- [1] Suction head with moisture trap
- [2] Pop-up unit
- [3] Vacuum hose release button
- [4] Function buttons
- [5] Housing
- [6] Drip tray

QVac accessories

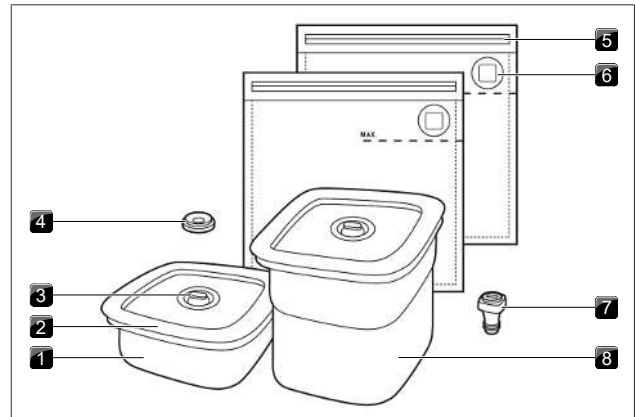





Fig. 4.2 Accessories

- [1] 1-litre vacuum box
- [2] Lid with seal
- [3] Valve and button to release the vacuum
- [4] Marinating ring
- [5] Grip seal
- [6] Valve
- [7] Vacuum seal
- [8] 2-litre vacuum box

Function button	Mode for
Left	 vacuum boxes + vacuum bags
Middle	 vacuum seal (power setting)
Right	 marinating mode

Tab. 4.1 How it works

-  The power setting must not be used for vacuum boxes.

5 Functions and operation

Vacuum sealing and food safety

Vacuum sealing is no replacement for the preservation, cooling or freezing of foods. Removing air does not prevent microorganisms that cause food to spoil from continuing to spread. Perishable foods must also be chilled or frozen after vacuum sealing.

- i** Due to the risk of anaerobic bacteria, soft cheese, raw garlic, onions and mushrooms must never be vacuum sealed. Even though they are very rare, anaerobic bacteria can be very dangerous.

5.1 How to use the appliance

- i** Hot foods must not be vacuum sealed. Contents must be allowed to cool to room temperature before being vacuum sealed.

- ▶ Press the round cover on the pop-up unit.
 - The pop-up unit will come up.
- ▶ Take the suction head and pull the vacuum hose out to the desired length.
 - You will hear a click and feel some resistance.
 - The appliance is now ready to use.

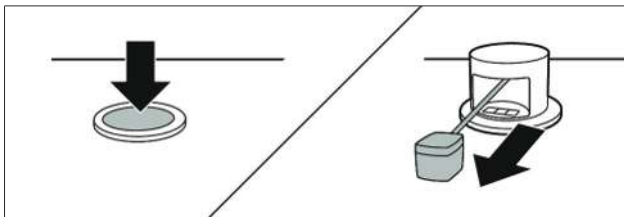

Fig. 5.1 How to use the appliance

- i** The vacuum hose can be pulled out to a maximum of 40 cm.
- i** As soon as enough air has been removed during the vacuuming process, the appliance will automatically switch off.
- i** After vacuum sealing wet products, the moisture trap must be cleaned.

How to stop the vacuuming process

The vacuuming process can be stopped at any time by pressing the corresponding function button.

5.2 How to use the vacuum bags

- i** Do not use vacuum bags to store liquids!
- i** Vacuum bags are suitable for use within a temperature range from -18 to 85 °C.
 - ▶ Place the food in the vacuum bag.
 - ▶ Ensure that the valve on the bag stays clean and dry.
 - ▶ Do not overfill the bag (only up to the line).

- ▶ Seal the bag by pressing the grip seal together and running your finger all the way along it
 - ▶ Check that the grip seal is positioned correctly to prevent leakage.
 - ▶ Position the suction head over the valve on the vacuum bag (where marked).
 - ▶ Press the left function button .
 - ▶ Gently press the suction head onto the valve.
 - ▶ Reposition the suction head and repeat the above steps if the valve on the vacuum bag does not open immediately.
- You can repeat this process as often as is necessary until you achieve the desired results.

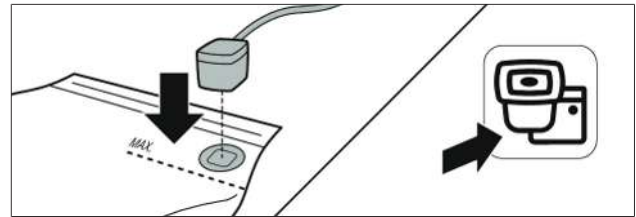

Fig. 5.2 How to use the vacuum bags

How to use the freezer stickers

When you wish to freeze vacuum-sealed foods for prolonged periods, or use vacuum bags for sous-vide cooking, the valve must also be sealed with a freezer sticker. This will prevent air from entering through the valve and into the bag.

- ▶ Check that the valve is clean and dry before applying the sticker.

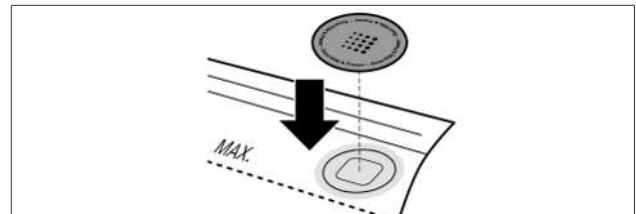

Fig. 5.3 How to apply the freezer stickers

Sous-vide cooking

The vacuum bags are suitable for sous-vide cooking. The material is designed to resist heat and water for long periods of time.

- ▶ Also seal the valve with a freezer sticker to prevent water from getting into the bag and affecting the cooking process (see "How to use the freezer stickers").

Reusing vacuum bags

The vacuum bags can be reused; however, they must be thoroughly cleaned after each use (see "6.1 How to clean vacuum bags"). Bags that have been used for raw meat, fish or poultry must not be reused.

5.3 How to use the vacuum boxes

- i** QVac vacuum boxes are perfect for storing liquids as well as dry or soft products (e.g. berries).
- i** The power setting must not be used for vacuum boxes.
 - ▶ Place the food to be vacuum sealed in the vacuum box.
 - ▶ Please observe the maximum fill level.
 - There must be a distance of at least 0.5 cm between the underside of the lid and the contents.

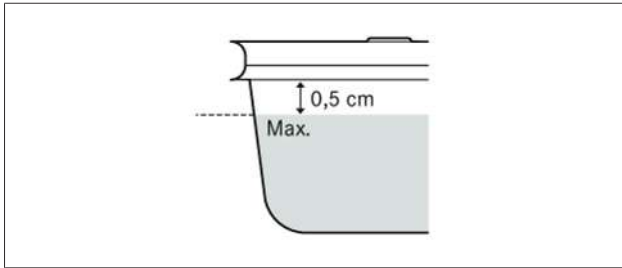



Fig. 5.4 Maximum fill level

- ▶ Please ensure that the seals on the lid and valve are clean, dry and undamaged.
- ▶ Place the lid on the container and press it on.
- ▶ Ensure that the lid is closed properly.
- ▶ Place the suction head on the round valve.
- ▶ Press the left function button .

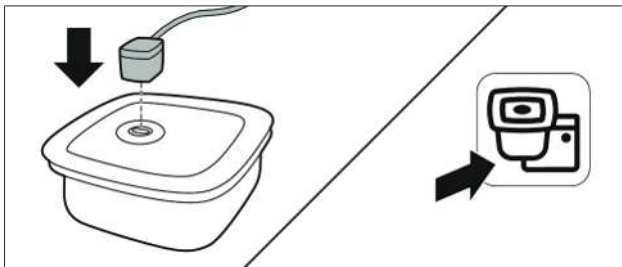

Fig. 5.5 How to use the vacuum box

- i** Thanks to the snap lock, you do not need to hold the suction head during the vacuuming process.

How to open the vacuum box after vacuum sealing

- ▶ The vacuum must be released to open the vacuum box.
- ▶ To do this, tilt the vacuum valve.

5.4 How to use the vacuum seal (power setting)

- i** The power setting generates maximum suction power and is only intended for vacuum seals.

The QVac vacuum seal can be used with conventional glass bottles or strong PET bottles with an opening diameter of 17 to 22 mm. Bottles made of other materials can be crushed by the force generated by the vacuum.

- ▶ Rinse the vacuum seal before use.
 - The sealing process will work better if the vacuum seal is clean.
- ▶ Close the wine bottle with the vacuum seal.
- ▶ Connect the suction head to the valve on the vacuum seal.
- ▶ Press the middle function button .

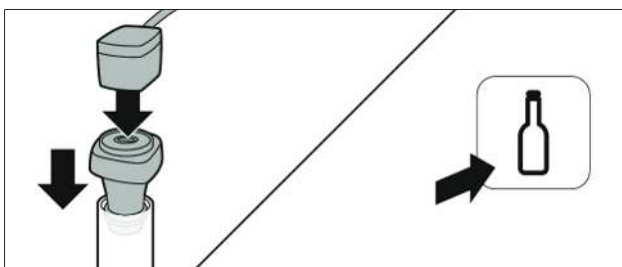



Fig. 5.6 How to use the vacuum seal

How to open the vacuum seal after vacuum sealing

- ▶ Release the vacuum to open the vacuum seal.
- ▶ To do this, tilt the vacuum valve.

5.5 How to use the marinating ring (for fast marinating)

- ▶ Place the ingredients and the marinade in a vacuum box.
- ▶ Carefully remove the valve on the top of the vacuum box lid.
- ▶ Close the vacuum box with the lid.
- ▶ Place the marinating ring on the lid of the vacuum box.
- ▶ Connect the suction head to the marinating ring.
- ▶ Start the marinating process by pressing the right function button .
 - Throughout the process, the system will go through several cycles that help the food to absorb the marinade in just a few minutes.
 - The function button  starts a marinating process that is five minutes longer. Each time you press the button, the marinating time is extended by 5 minutes. This will marinate the food more effectively.

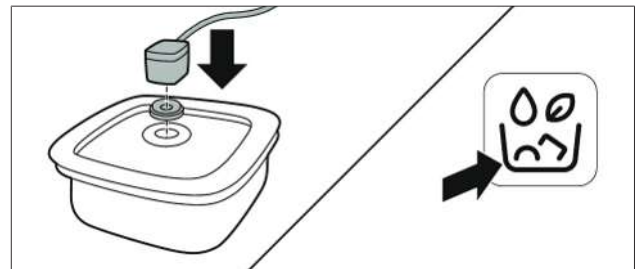

Fig. 5.7 How to use the marinating ring

6 Cleaning and maintenance

The appliance can be cleaned with warm water and washing-up liquid or liquid glass cleaner and a soft cloth. Do not spray cleaning products directly onto the appliance. Put your appliance away after each use to prevent damage.

- ▶ Never use steam cleaners, abrasive sponges, scouring pads or chemically aggressive cleaning agents (e.g. oven cleaner spray).
- ▶ Make sure that the cleaning agent does not contain any sand, soda, acids, lyes or chloride.

6.1 How to clean vacuum bags

If you wish to reuse the vacuum bags, they must be thoroughly cleaned after each use.

- ▶ Clean the vacuum bags in the dishwasher or with warm water and washing-up liquid.
 - Vacuum bags must be allowed to dry completely after cleaning.

6.2 How to clean the vacuum boxes

QVac vacuum boxes can be cleaned in the dishwasher (programmes up to 65 °C). The seal can also be taken out of the lid and cleaned with a mild cleaning product (e.g. warm water and washing-up liquid).

6.3 How to clean the moisture trap

Every time that you use your appliance with vacuum bags or moist foods, the moisture trap must be cleaned afterwards. To do this, use two fingers to remove the transparent section from the black part of the suction head.

- ▶ Clean the transparent section with warm water and washing-up liquid and then leave it to dry.

The moisture trap can also be cleaned in the dishwasher.

- i** When fitting the moisture trap on the suction head after cleaning, ensure that it is positioned correctly. There is only one position in which they can be joined without any resistance or excessive force.

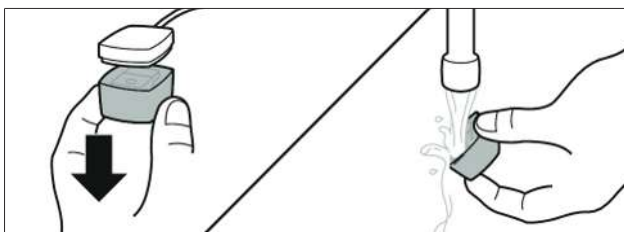

Fig. 6.1 How to clean the moisture trap

6.4 How to clean and replace the vacuum hose

The vacuum hose can be removed for cleaning or replacement.

- ▶ Pull the suction head out as far as it will go.
- ▶ With two fingers, press the two release buttons in the top of the pop-up unit.
- ▶ At the same time, gently pull on the vacuum hose attachment.

- ▶ Pull the transparent vacuum hose out of the pop-up unit until the hose coupling appears.
- ▶ Continue to pull until the roll-up mechanism reaches a stop position. This will allow you to remove the hose.
- ▶ Use both hands to open the coupling and remove the vacuum hose.
- ▶ Hold one side of the coupling tight and release the other side by twisting it out of its attachment.
- ▶ Please ensure that you are only holding and turning the coupling and not the hose.

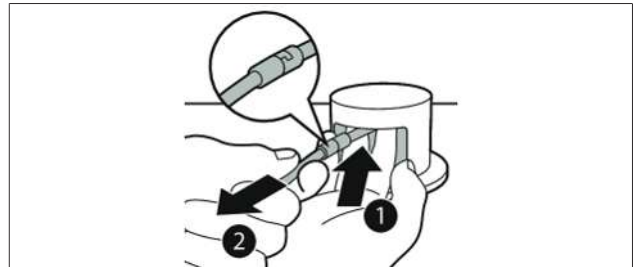

Fig. 6.2 How to pull out the vacuum hose coupling



Fig. 6.3 How to remove the vacuum hose from the coupling

- i** When you remove the vacuum hose, you must ensure that the coupling is not drawn back into the pop-up unit without the hose attached.

- i** Never press the two release buttons after the hose has been removed. This may cause the vacuum hose coupling to be drawn back into the appliance.

- ▶ Remove the transparent moisture trap and rinse the hose with alcohol or with warm water and washing-up liquid.
- ▶ Rinse all food and liquid residues well.
- ▶ Carefully shake the hose after cleaning to remove any remaining liquid.

- i** The hose does not need to be completely dry before using it again. The appliance was designed to be able to handle small amounts of liquid in the system.

- ▶ Check that the O-ring seal is on the hose and that it is clean and undamaged.
- ▶ Reattach the vacuum hose to the coupling.
- ▶ Make sure it is positioned correctly.
- ▶ Please do not use excessive force.

The hose and coupling can only be joined in one direction without using too much force.

When the vacuum hose has been reattached:

- ▶ pull the suction head out again and then let it go carefully.
- ▶ At the same time, press the two “release” buttons inside the pop-up unit.

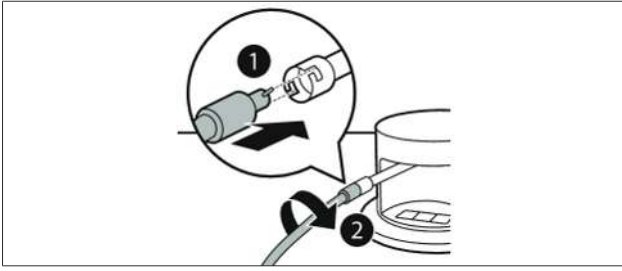

Fig. 6.4 How to attach the vacuum hose

i If the vacuum hose needs to be replaced, follow the steps above but using a new original spare part.

6.5 How to remove water from the appliance

How to remove water from the appliance

If water gets into the appliance, it is caught in the drip tray.

There are two reasons why water may get into the appliance:

- liquid may enter the appliance through the hose;
- liquid may be spilled on the appliance and get inside through the seal.

If a small amount of liquid has gathered in the drip tray, it will dry by itself. However, if a larger amount of liquid has gathered in the drip tray, it must be removed. The drip tray can only be accessed from under the worktop where the appliance has been attached.

- ▶ Pull the drip tray out and empty it.
- ▶ Clean the drip tray and put it back in the housing.

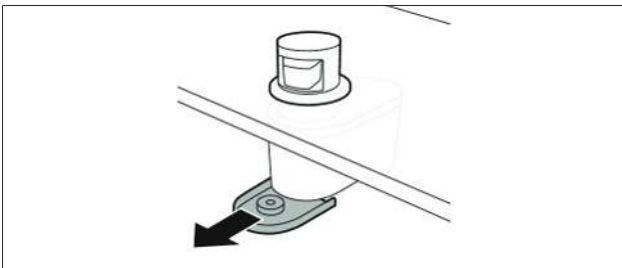

Fig. 6.5 How to pull out the drip tray

7 Troubleshooting

► Observe all safety and warning information (Safety).

i You can often remedy faults and errors yourself. This saves time and money as you don't need to call out customer services.

Operating situation	Cause	Remedy
The appliance has no suction power	There is no mains voltage	Check that the buttons are lit up and that the appliance is connected to the power supply.
	System fault	Restart the appliance. To do this, push the pop-up unit back in and then back out again.
	Soiling	Ensure that the moisture trap is clean and that the safety valve is not stuck.
		Contact the BORA Service Team.
The appliance is not sucking air out of the vacuum bag	The grip seal on the bag is not airtight or is faulty	Check that the grip seal is closed properly. Use another bag to check whether the same problem arises.
	The bag valve is dirty	Place the bag on a flat surface and ensure that there are no food residues under the valve.
	The suction head is not positioned correctly	Start the vacuuming process again and press the suction head lightly onto the valve.
Air gets into the bag after vacuuming	The grip seal or bag valve is dirty	Check the grip seal and valve for food residues. Clean the seal and the valve and dry the inside of the bag before restarting the vacuuming process.
Air cannot be sucked out of the vacuum box or vacuum seal or the seal will not stay in place	The valve or seal is dirty	Ensure that the seal is clean and intact.
	The vacuum box is not closed properly	Press the lid down on all four sides so that the vacuum box is tightly closed.
	Faulty vacuum box	Check the edges of the container for cracks and scratches. Air can get back into the container through any gaps.
The marinating function does not work or switches off immediately after the second vacuuming attempt	The valve is fitted inside the lid	Remove the valve from the lid before marinating.
	The marinating ring is missing	Place the marinating ring on the lid.
	Soiled suction head	Clean the suction head thoroughly.
Appliance is beeping (3 beeps in a row)	Software error	Disconnect the appliance from the mains, wait 20 seconds and then plug it back in.
		Contact the BORA Service Team.

Tab. 7.1 Troubleshooting

8 Installation

► Observe all safety and warning information (Safety).

8.1 Scope of delivery

Scope of delivery	Quantity
Built-in vacuum sealer	1
Power supply	1
Vacuum box (1 litre)	1
Vacuum box (2 litres)	1
Vacuum bag (0.6 litres)	5
Vacuum bag (1.5 litres)	5
Vacuum bag (2.1 litres)	5
Freezer stickers	15
Vacuum seal	2
Marinating ring	1
Sealing tape	1

Tab. 8.1 Scope of delivery

Checking the scope of delivery

- Make sure the delivery is complete and check it for damage.
- Immediately notify the BORA Service Team if parts are missing or damaged.
- Do not under any circumstances install parts which are damaged.
- Dispose of transport packaging in the proper manner (see "9 Decommissioning, disassembly and disposal").

8.1.1 Components

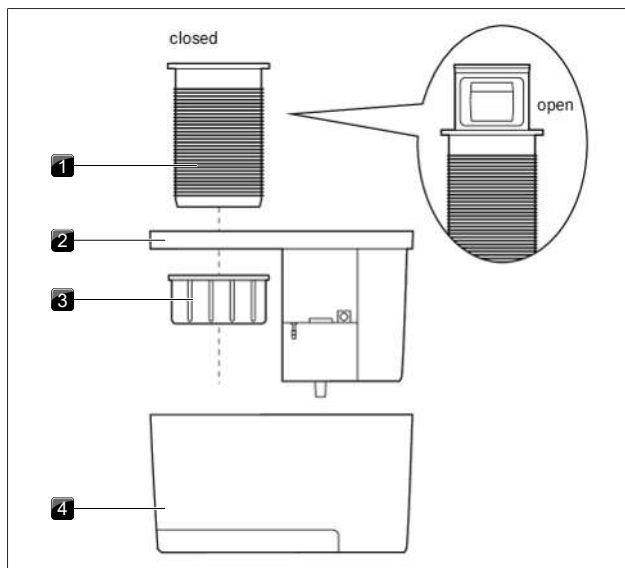

Fig. 8.1 Components

- [1] Pop-up unit
- [2] Base unit
- [3] Mounting ring
- [4] Housing

8.2 Assembly instructions

8.2.1 Installation options

There are two ways of installing the appliance:

- Surface mounting (A)
- Flush installation (B)

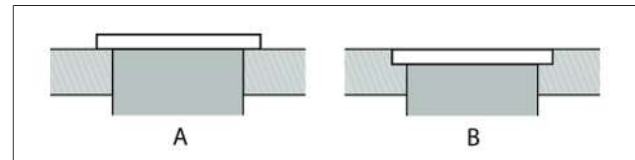

Fig. 8.2 Installation options

i For flush installation, the worktop must be at least 10 mm thick. In the case of thinner worktops, a substructure is required.

8.2.2 How to prepare the worktop

- Ensure that there is sufficient space under the worktop for the base unit and housing.
- The mains supply cable is 200 cm long.

The housing can be installed independently of the pop-up unit in any direction. This makes it easier to find a suitable place in the kitchen for installation.

To be able to remove or insert it without any issues, it must be positioned in such a way that the drip tray has 5 cm of clearance underneath and to the side.

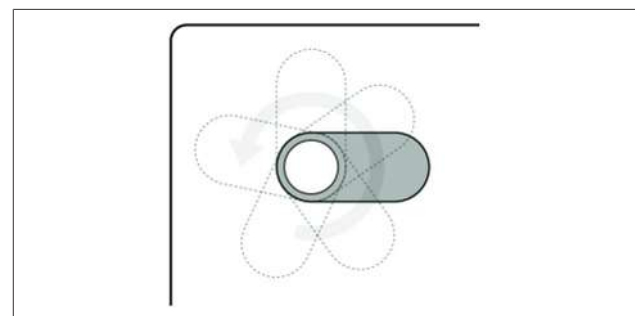

Fig. 8.3 Variable positioning of the appliance

i The housing must be accessible for maintenance work.

To make it easier to use, we recommend installing it a little further back in the worktop. When the base unit and connections are turned to the front, this makes it easier to reconnect the cables once the base unit has been fixed to its installation site.

8.3 Worktop cut-out

- Create the worktop cut-out taking into account the specified cut-out dimensions.
- Make sure that the cut surfaces of the worktops are properly sealed.
- Comply with the instructions of the worktop manufacturer.

8.3.1 Cut-out dimensions

Surface mounting

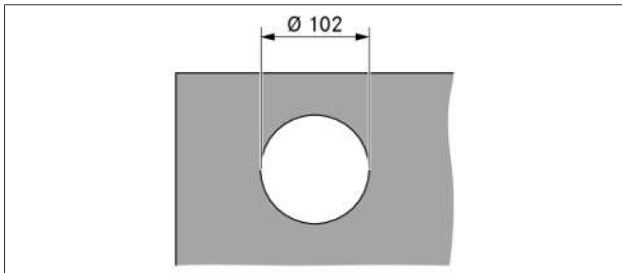

Fig. 8.4 Cut-out dimensions for surface mounting

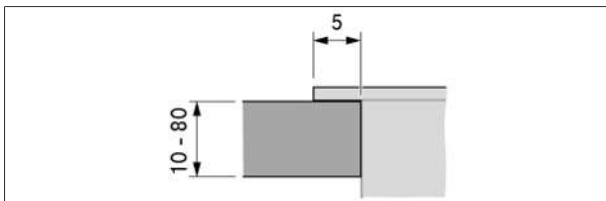

Fig. 8.5 Dimension of support for surface mounting

Flush installation

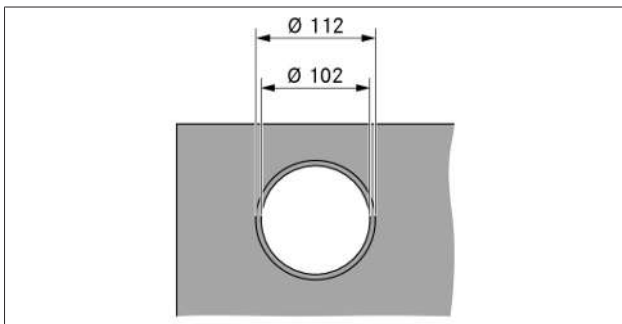

Fig. 8.6 Cut-out dimensions for flush installation

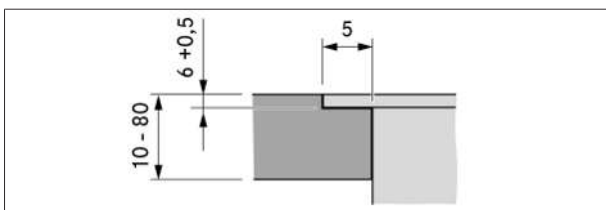

Fig. 8.7 Flush installation rebate dimensions

8.4 Installing the appliance

8.4.1 Preparing for installation

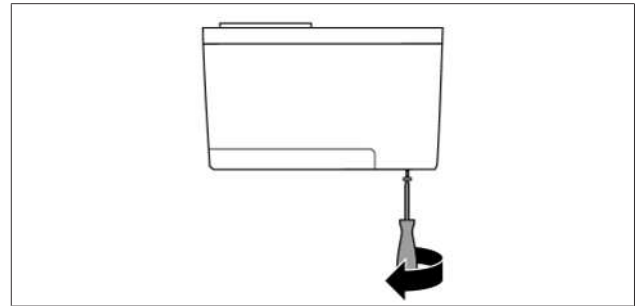

Fig. 8.8 Remove the screws

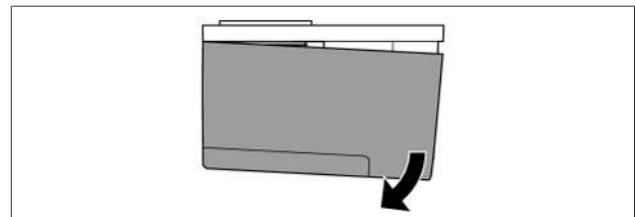

Fig. 8.9 Tilt the housing

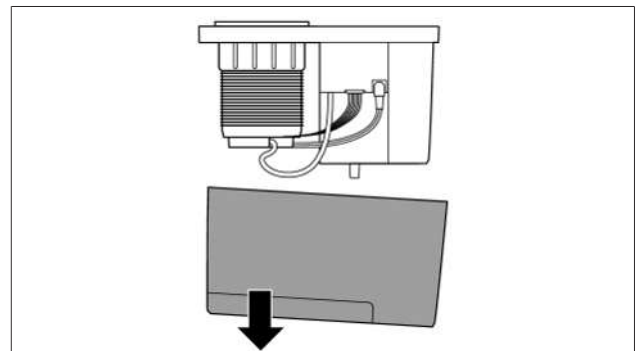

Fig. 8.10 Remove the housing

How to disassemble the pop-up unit

How to disassemble the housing

- ▶ Carefully remove the vacuum hose and the 2 electrical connections from the base unit.
- ▶ Turn the mounting ring and remove it from the pop-up unit.
- ▶ Take the pop-up unit out of the base unit.

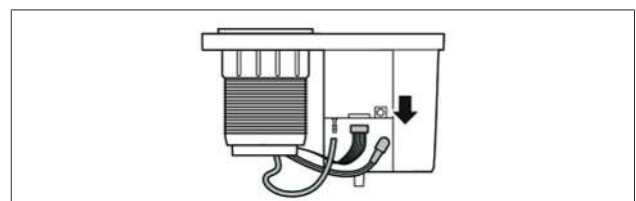

Fig. 8.11 Remove the connections

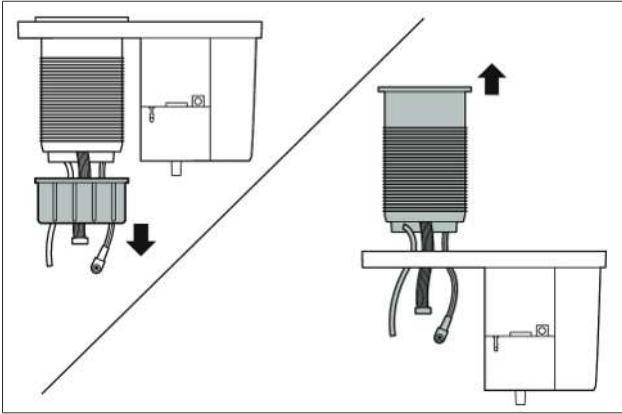

Fig. 8.12 How to disassemble the pop-up unit

8.4.2 Standard installation

i In standard installation the base unit is attached with the connections at the front.

i The housing must be accessible for maintenance work.

How to fit the pop-up unit in the worktop

- ▶ Stick the sealing tape on the contact surface of the pop-up unit.
- ▶ Guide the pop-up unit down through the opening in the top of the worktop.
- ▶ Ensure that the controls are facing forwards.
 - The logo should be facing the user.
 - The “FRONT” sticker on the pop-up unit shows the position of the controls.

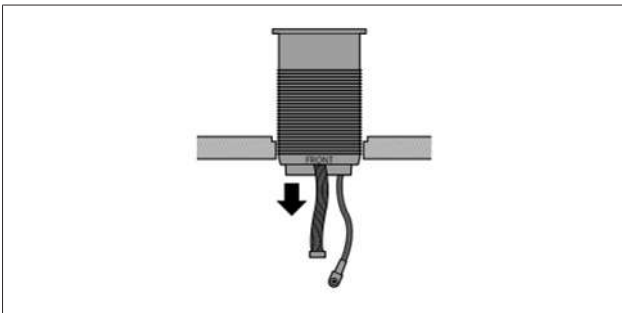

Fig. 8.13 Insert the pop-up unit

- ▶ Remove the film from the adhesive on the top of the base unit.
 - This will enable you to temporarily attach the base unit to the underside of the worktop and will make installation easier.

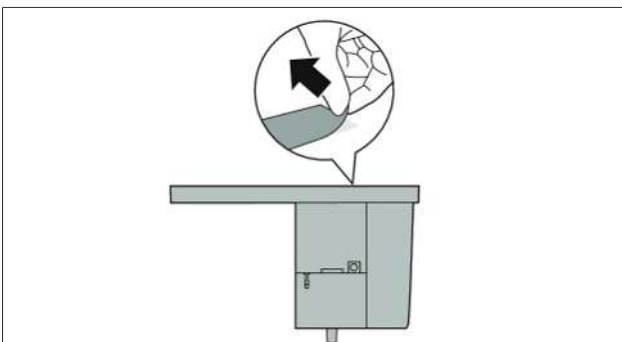

Fig. 8.14 Remove the film from the base unit

- ▶ Push the base unit over the pop-up unit cylinder under the worktop.
- ▶ Press the base unit firmly onto the worktop from below.
 - The adhesive will now ensure that the base unit stays in place.

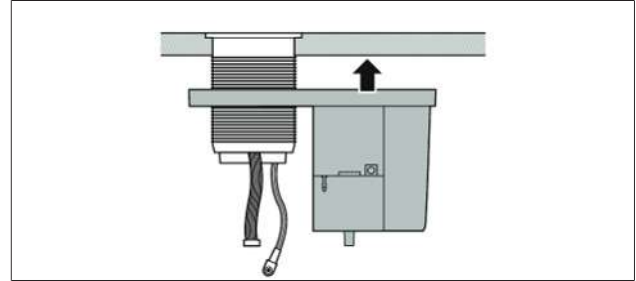

Fig. 8.15 Position the base unit

- ▶ Push the mounting ring over the cylinder.
- ▶ Turn the mounting ring anticlockwise right to the top to attach the base unit to the worktop from below.

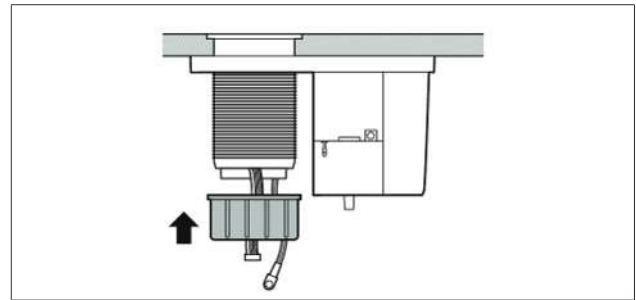

Fig. 8.16 Secure the appliance

How to attach the vacuum hose

- ▶ Reattach the vacuum hose to its connector.
- Please ensure that there are no kinks in the vacuum hose.
- ▶ Fit the vacuum hose inside the clips around the bottom of the pop-up unit.

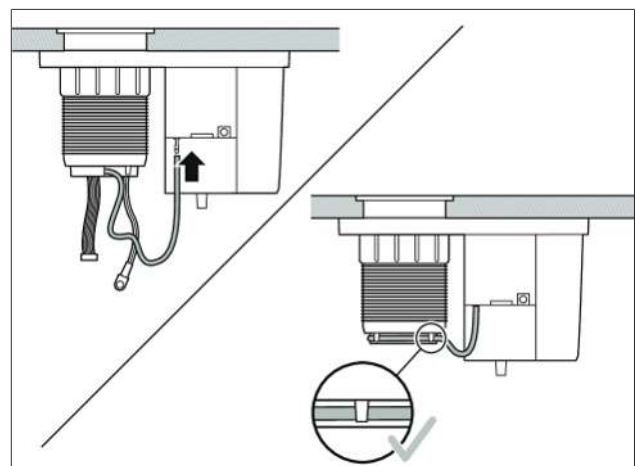

Fig. 8.17 Connect the vacuum hose and fix in place with the clips

Electricity supply

- ▶ Connect the two electrical connections on the base unit.
 - The white cable must be plugged in with the safety clip facing outwards.
 - If the white cable is not correctly plugged in, the appliance will not work.

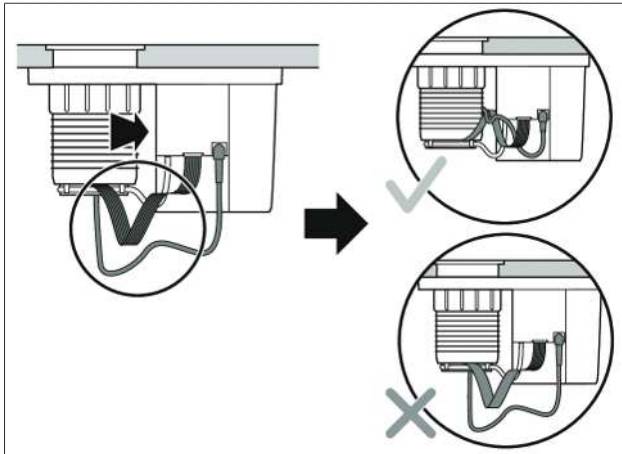

Fig. 8.18 Connect the cables

- i** If the appliance has been correctly connected to the mains, an acoustic signal will confirm this when it is used for the first time. If it has not been connected correctly, the appliance will remain silent and the buttons will not light up, or a repetitive acoustic signal will be heard.

How to fit the housing

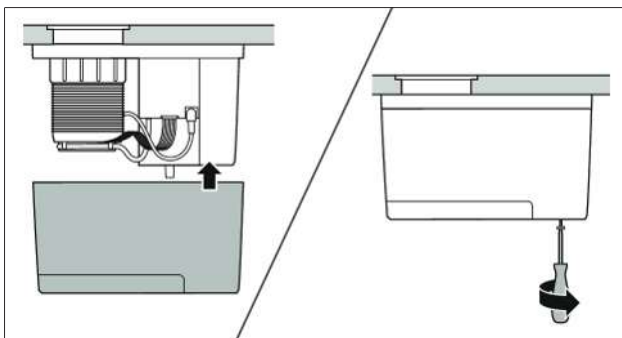

Fig. 8.19 Push the housing on and screw tight

How to connect the power supply

- ▶ Connect the mains supply cable to the base unit.
- ▶ Connect the mains supply cable to the mains.

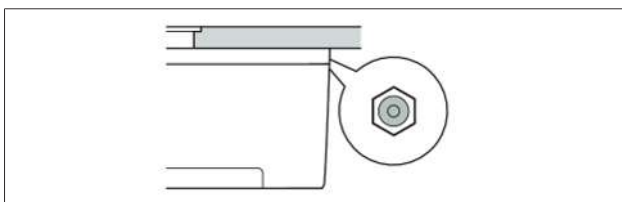



Fig. 8.20 Connect the mains supply cable

8.5 Initial operation

Function test

- ▶ Press the round cover on the pop-up unit.
 - The appliance will pop up and the control unit with the extendable suction head will be accessible.
- ▶ Pull out the suction head.
- ▶ Press the function button .
- The vacuum process will begin.
- ▶ Hold the suction head in your palm or on a hard surface.

You must be able to feel the suction. The appliance will switch off automatically. Alternatively, you can switch off the appliance by pressing the function button  again.

8.6 Sealing the appliances

- i** Step only required in the case of surface mounting.

- ▶ Once all of the installation work and initial operation is complete, seal the pop-up unit all round with silicone sealant.
- ▶ Make sure that no silicone sealant gets under the cooktop.

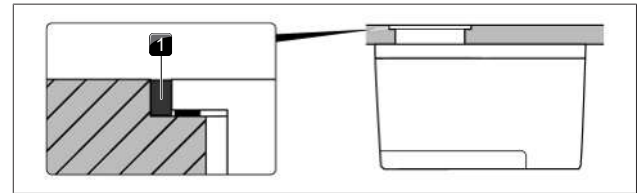

Fig. 8.21 Seal the pop-up unit

- [1] Silicone sealant

8.7 Handover to user

Once installation is complete:

- ▶ Explain the main functions to the user.
- ▶ Explain all safety-related aspects of operation and handling to the user.
- ▶ Provide the user with the accessories and operating and installation instructions, which are to be kept in a safe place.

9 Decommissioning, disassembly and disposal

- ▶ Observe all safety and warning information (Safety).
- ▶ Follow the enclosed manufacturer's information.

- ▶ Take the appliance to a regional collection point for the return and further processing of electrical and electronic components and other materials.

9.1 Decommissioning

Decommissioning refers to ultimate decommissioning and disassembly. Following decommissioning, the appliance can either be installed in another unit, sold on privately or disposed of.

- ▶ Switch the appliance off before decommissioning (see operating instructions)
- ▶ Disconnect the appliance from the power supply.

9.2 Disassembly

To be removed, the appliance must be accessible for disassembly and disconnected from the power supply.

- ▶ Dispose of the old appliance and any soiled accessories as described under "Environmentally-friendly disposal".

9.3 Environmentally-friendly disposal

9.3.1 Disposal of transport packaging

- i** The packaging protects the appliance from damage during transport. The packaging materials have been selected taking into account the environment and their disposal and are therefore recyclable.

Recycling the packaging saves raw materials and reduces waste. Your specialist retailer will take the packaging back.

- ▶ Give the packaging to your specialist retailer or
- ▶ dispose of the packaging correctly observing regional regulations.

9.3.2 Disposal of the old appliance



Electrical appliances with this mark must not be disposed of in the household waste at the end of their service life. They must be disposed of at a collection point for the recycling of electrical or electronic appliances. Information on this can be obtained from the city or local councils.

Waste electrical and electronic appliances often still contain valuable materials. However, they also contain harmful substances that were necessary to make them work and ensure their safety. If placed in the household waste or handled incorrectly, they may harm human health and damage the environment.

- ▶ Never dispose of your old appliance in the household waste.

10 Warranty, technical service, spare parts, accessories

► Observe all safety and warning information (Safety).

10.1 BORA manufacturer's warranty

BORA provides its end customers with a 2-year manufacturer's warranty for its products. The end customer is entitled to this warranty in addition to the statutory claims for defects against the sellers of our products.

The manufacturer's warranty applies to the BORA products listed here, which are sold by authorised BORA retailers or by BORA trained salespersons and are installed within the European Union (overseas territories excluded), Switzerland, Norway, UK and Iceland, with the exception of BORA products labelled as universal or accessories:

- BORA QVac built-in vacuum sealer
- BORA products that were not sold by authorised BORA dealers or salespersons trained by BORA
- Damage caused by non-adherence to the operating instructions (including product care and cleaning). This represents improper use.
- Damage to the following components:
vacuum valve, drip tray, decorative ring and decorative cover, plastic parts and other wearable parts
- Secondary damage or claims for damages beyond the defect

Legal claims, particularly statutory claims for defects or product liability are not limited by the warranty and can be asserted free of charge.

If a defect is not covered by the manufacturer's warranty, a claim may be made against the BORA Technical Service.

. BORA shall not assume the resulting costs.

The laws of the Federal Republic of Germany apply to these warranty conditions.

You can contact us at:

BORA Vertriebs GmbH & Co KG, Innstraße 1, 6342 Niederndorf, Austria

- Telephone: +800 7890 0987
Monday to Thursday from 8 a.m. to 6 p.m. and Friday from 8 a.m. to 5 p.m.
- Email: info@bora.com

10.1.1 Warranty extension

You can extend the warranty by registering at www.bora.com/registration.

10.2 Service

BORA Service:

see reverse side of operating and assembly instructions



► In the case of faults you cannot fix yourself, contact your BORA specialised retailer or the BORA Service Team appears in the cooktop extractor control knob display.

The BORA Service Team will require the type designation and serial number of your appliance (FD number).

This information is provided on the nameplate in the back of the operating instructions as well as on the bottom of the appliance or on the welcome card provided upon delivery.

10.3 Full replacement of the appliance

- Use only original parts when fully replacing the appliance.
- A full replacement of the appliance may only be carried out by the BORA Service Team.

10.4 Accessories

Special accessories for BORA QVac appliances:

- QVac 1 litre vacuum boxes
- QVac 2 litre vacuum boxes
- QVac vacuum seal
- QVac marinating ring
- QVac vacuum bag (0.6 litres)
- QVac vacuum bag (1.5 litres)
- QVac vacuum bag (2.1 litres)
- QVac vacuum bag set (5 × 0.6 litres/5 × 1.5 litres/5 × 2.1 litres)

Operating and installation instructions:

○Original

⊙Translation

Manufacturer: BORA Vertriebs GmbH & Co KG

The distribution and duplication of this document, as well as the use and disclosure of its contents are prohibited unless expressly authorised. Great care was taken when devising these operating and installation instructions. However, it may be the case that later technical changes have not yet been added or the corresponding contents have not yet been modified. We apologise for this. An up-to-date version can be requested from the BORA Service team. Misprints and errors excepted.

© BORA Vertriebs GmbH & Co KG

All rights reserved.

D

BORA Lüftungstechnik GmbH

Rosenheimer Str. 33
83064 Raubling
Deutschland
T +49 (0) 8035 / 9840-0
F +49 (0) 8035 / 9840-300
info@bora.com
bora.com

A

BORA Vertriebs GmbH & Co KG

Innstraße 1
6342 Niederndorf
Österreich
T +43 (0) 5373 / 62250-0
F +43 (0) 5373 / 62250-90
mail@bora.com
bora.com

INT

BORA Holding GmbH

Innstraße 1
6342 Niederndorf
Austria
T +43 (0) 5373 / 62250-0
F +43 (0) 5373 / 62250-90
mail@bora.com
bora.com

AU NZ

BORA APAC Pty Ltd

100 Victoria Road
Drummoyn NSW 2047
Australia
T +61 2 9719 2350
F +61 2 8076 3514
info@boraapac.com.au
bora-australia.com.au

