

# BORA QVac

PLANNING DOCUMENTS

# BORA QVac

## built-in vacuum sealer

### highlights

#### **Unique installation concept**

Thanks to the innovative and unique installation concept, the BORA QVac doesn't take up any of the coveted space on kitchen work surfaces: like the substructure for the cooktop extractors, the device is fitted below the worktop. The built-in vacuum sealer can be installed either flush or surface mounted.

#### **Ultra-rapid marinating**

The marinating ring, which is placed on one of the associated vacuum boxes, creates a vacuum. The resultant marinating process takes no more than ten minutes rather than several hours or days, and enables marinades to penetrate food particularly deeply.

#### **Keep liquids fresh for longer**

The vacuum seal keeps bottled liquids, such as wine or oil, usable for longer after they have been opened. Once vegetables have been cooked, the resultant stock can even be stored as a sauce base, for example.





## QVACSS

QVac Vacuum set Stainless Steel



## QVACAB

QVac Vacuum set All Black



## QVACVBO1

QVac Vacuum boxes  
(2x 1 Liter)



## QVACVBO2

QVac Vacuum bags  
(2x 2 liter)



## QVACVBE1

QVac Vacuum bags  
(15x 0,6 liter)



## QVACVBE2

QVac Vacuum bags  
(15x 1,5 liter)



## QVACVBE3

QVac Vacuum bags  
(15x 2,1 liter)



## QVACVBES

QVac Vacuum bag set  
(5x 0,6 liter / 5x 1,5 liter / 5x 2,1 liter)



## QVACVV

QVac Vacuum closure  
(2 pieces)



## QVACMR

QVac Marinate ring

QVac Vacuum set Stainless Steel

QVac Vacuum set All Black

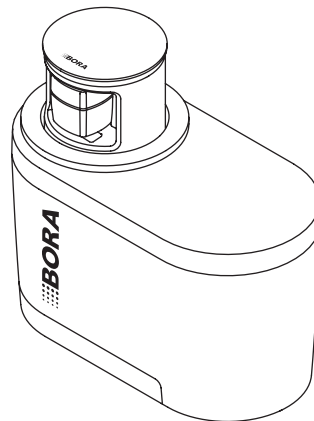
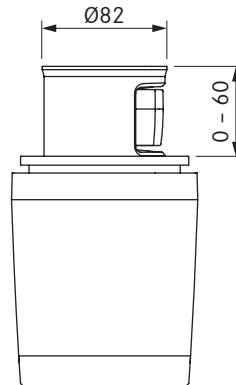
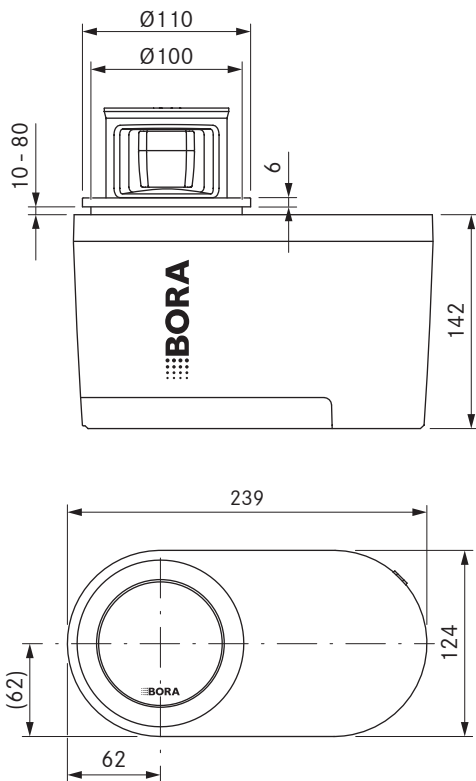

## Technical data

Supply voltage	100 - 240 V
Frequency	50 - 60 Hz
Maximum power consumption	24 W
Power supply cable length	2 m
Suction power	≈ 10 l/min
Maximum vacuum pressure	-90 kPa
Dimensions (width x depth x height)	239 x 124 x 142 mm
Weight (incl. accessories/packaging)	3,48 kg
Surface material	stainless steel
Vacuum hose extension length	400 mm

## Product description

- Unique installation concept
- Ultra-rapid marinating
- Keep liquids fresh for longer

## Scope of delivery

- 1x QVac Built-in vacuum unit
- 1x QVac Vacuum box 1l
- 1x QVac Vacuum box 2l
- 1x QVac Marinate ring
- 2x QVac Vacuum closure
- 5x QVac Vacuum bags 0,6l
- 5x QVac Vacuum bags 1,5l
- 5x QVac Vacuum bags 2,1l
- 15x Freezer sticker for vacuum bag
- 1x Power supply cable EU (2m)
- Operating and installation instructions

## Accessories

- QVac Vacuum boxes 2x 1l QVACVBO1
- QVac Vacuum boxes 2x 2l QVACVBO2
- QVac Vacuum closure 2 pcs. QVACVV
- QVac Marinate ring QVACMR
- QVac Vacuum bags 15x 0,6l QVACVBE1
- QVac Vacuum bags 15x 1,5l QVACVBE2
- QVac Vacuum bags 15x 2,1l QVACVBE3
- QVac Vacuum bags Set (5x 0,6l, 5x 1,5l, 5x 2,1l) QVACVBES
- Power supply cable UK (2m)

## Product- and planning instructions

- For flush mounting, the worktop must be at least 10 mm thick.
- For thinner worktops, a substructure is necessary.
- The housing must remain accessible for maintenance work.
- Standard installation is with the connections facing forward.

# Positioning

BORA QVac built-in vacuum sealer

## Variable positioning of the appliance

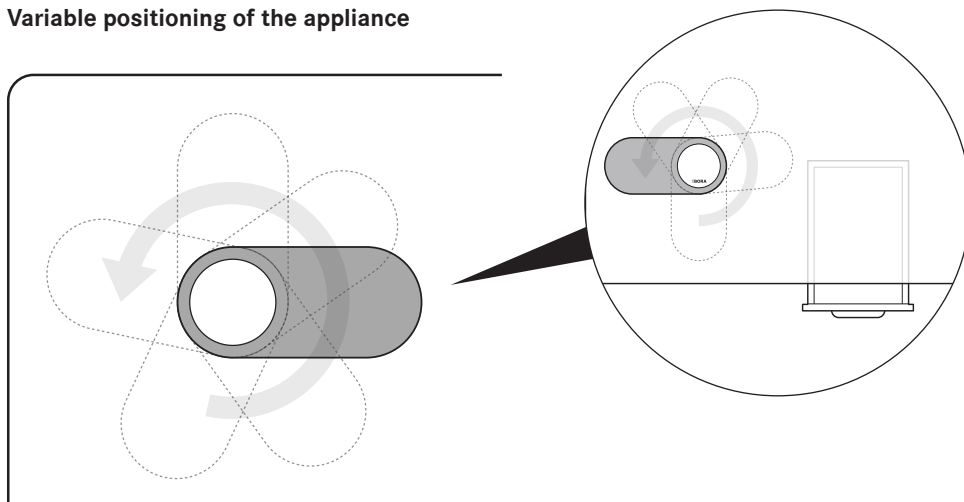

- To make it easier to use, we recommend mounting it a little further back on the worktop.
- The logo should point in the direction of the user.
- The „FRONT“ sticker on the pop-up unit indicates the position of the control.

## Cut-out dimensions

BORA QVac built-in vacuum sealer

### Flush installation

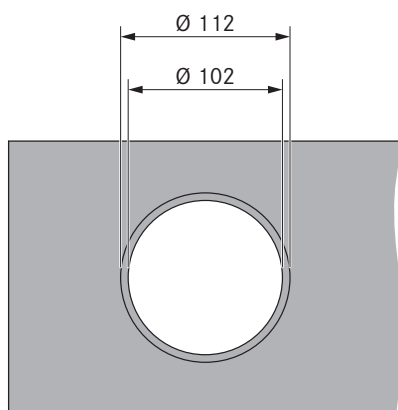
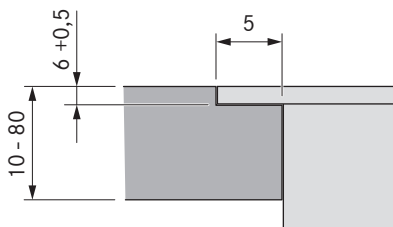

### Surface mounting

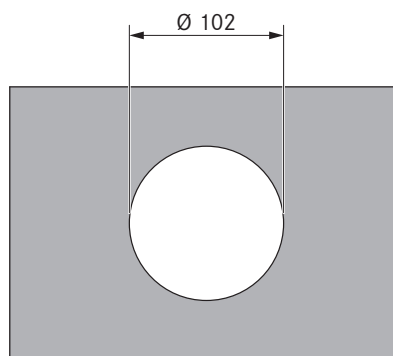
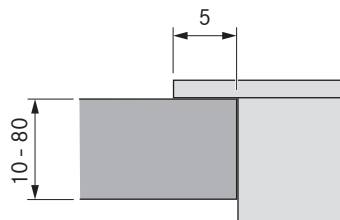

### Important planning instructions:

- For standard installation, the unit is installed with the connections facing forwards.
- The housing must remain accessible for maintenance work.
- For flush mounting, the worktop must be at least 10 mm thick. A substructure is necessary for thinner worktops.
- For easy removal or insertion, the unit must be positioned in such a way that the drip tray has a free space of 5 cm at the bottom and 5 cm at the side.
- Please note the worktop manufacturer's instructions with regard to the suitability of the worktop. Worktop cut-outs must be moisture-sealed using suitable means or, where necessary, fitted with a thermal insulator (e.g. in the case of Corian or HiMacs worktops).

---

D

BORA Lüftungstechnik GmbH  
Rosenheimer Straße 33  
D-83064 Raubling, Germany  
T +49 (0) 80 35 98 40-0  
F +49 (0) 80 35 98 40-300  
info@bora.com

A

BORA Vertriebs GmbH & Co KG  
Innstraße 1  
A-6342 Niederndorf, Austria  
T +43 (0) 53 73 6 22 50-0  
F +43 (0) 53 73 6 22 50-90  
mail@bora.com

INT

BORA Holding GmbH  
Innstraße 1  
A-6342 Niederndorf, Austria  
T +43 (0) 53 73 6 22 50-0  
F +43 (0) 53 73 6 22 50-90  
mail@bora.com

EN

---

Errors and technical changes reserved.

Due to ongoing improvements thanks to research and development, BORA reserve the right to change product specifications or features without prior notice. BORA shall not be held liable for printing errors. Publication of images and diagrams requires written authorisation.

**bora.com**