

# TAP6014

## Arroscia 4 in 1 Hot Water Tap

**LAMONA**  
Exclusive to Howdens Joinery Co.

11-19

### Guarantee (UK only):

Your tap has the benefit of a comprehensive manufacturer's guarantee, details of which are shown on your Proof of Purchase Document. Any claim during the period of the guarantee must be accompanied by the Proof of Purchase. The product must be correctly installed and operated in accordance with the manufacturer's instructions and used for normal domestic purposes. This guarantee does not cover accidental damage, misuse or alterations which are likely to affect the product. The guarantee is invalid if the product is tampered with, or repaired by any unauthorized person. The guarantee in no way affects your statutory or legal rights.

### Care Instructions for your Kitchen Sink Mixer:

To maintain the appearance of this tap, ensure that it is regularly cleaned only using a clean, soft damp cloth. A solution of warm water and a mild liquid detergent may be used where necessary, and then the fitting rinsed thoroughly and wiped dry. Any other cleaning action will invalidate your warranty.

Abrasive cleaners, scouring cleaners and acidic cleaners **must not be used** under any circumstances. Avoid contact with all solvents (including chlorinated solvents, ketones or acetones as these may result in surface deterioration or etching). Also avoid contact with any harsh household chemicals such as oven cleaners, drain cleaners, rust removers, paint strippers and toilet bowl cleaners, bar keepers friend or Brasso.

Where the tap has a removable aerator on the spout exit it can be removed and cleaned periodically to maintain optimum flow performance.

### Important Technical Data:

Minimum operating pressure (hot): 0.5 bar
Maximum operating pressure: 5.5 bar*
Flow characteristics: Domestic Hot, Cold & Filtered share outer single flow spout. Boiled water: Through centre spout channel.

Minimum operating pressure (cold): 1.5 bar
Maximum domestic hot water temperature: 70°C*
Recommended domestic hot water temperature: 46°C

\*If these temperatures or pressures are exceeded, even for short periods, damage can result. In these instances a thermostatic mixing or pressure reducing valve should be installed.

This product is manufactured in accordance with recognised European standards. Please ensure that your kitchen mixer is fitted in accordance with Local Water Byelaws. **Where hot and cold water mix within the tap, then suitable non return (check) valves should be installed to both the hot and cold supplies to prevent backflow**, a preinstalled non return valve on the cold supply flexi hose (F1) is already supplied (see instructions key).

Hot and cold supply pressures should be as closely balanced as possible for best results. Supply pipes should maintain the maximum diameter until immediately before the fitting. The differential between the hot and cold water supply temperatures should be sufficient to allow correct mixing function.

These installation guidelines have been prepared for your direction and you must exercise due care at all times. We do not accept responsibility for problems that may occur through improper installation. Whilst assembling the tap take care not to accidentally loosen any factory fixed assemblies.

This tap has been 100% assembly tested; therefore you may expect a small residual amount of water to remain in the tap when delivered. Any water marks can be removed using the above care advice.

### Installation Preparation

 **Before installing the new mixer it is essential that you thoroughly flush through the supply pipes in order to remove any remaining solder, swarf or impurities from your system. Failure to carry out this simple procedure could cause problems or damage to the workings of the mixertap or boiler.**

**We recommend installing particle filters (not shown) and isolation valves (G1) to both the hot and cold feed pipes in an accessible position. This will help to prevent premature failure of the valves and ease any future maintenance.**

**Ensure you have suitable domestic hot and cold water pressure before installing this product (see technical data for more information).**

All parts should be removed from their packaging and inspected for any transport damage and that all parts are present prior to installation.

Shut off your water heating system and ensure that your mains stopcock is closed. Open the lowest hot and cold taps in the house and allow the water to run until fully stopped.

If replacing an existing tap, remove the tap & clean the end of the feed pipes using wire wool, the tap hole area should be free from dirt and sealant. Loosely position the tap and tail pipes to check if any alteration to the existing pipework is required, if this is the case do this now.

## Parts and Contents

Key	Description	Qty
A1	Mixer tap	1
A2	Base plinth	1
A3	Base plinth seal	1
A4	Sink or worktop (max. 50mm)	0
A5	White triangular plate (for use with steel sinks only)	1
A6	Lower gasket	1
A7	Metal horseshoe	1
A8	Fixing stud	1
A9	Fixing nut	1
B1	Cold filtered (from tap to boiler) flexible hose (M8 x 3/8" F), includes captive seal	1
B2	3/8" M x 1/4" F brass adaptor	1
B3	1/4" NPT M x 1/4" pushfit	1
B4	1/4" outside diameter plastic pipe	1**
C1	Cold filtered (from filter to tap) blue banded flexible hose (M8 x 3/8" F), includes captive seal	1
C2	3/8" M x 1/4" F brass adaptor	1
C3	1/4" NPT M x 1/4" pushfit	1
C4	1/4" outside diameter plastic pipe	1**
C5	Filter bracket	1
C6	Filter bracket screw	1
C7	Filter cartridge	1
C8	1/4" outside diameter plastic pipe	1**
C9	3/4" BSPF x 1/4" pushfit adaptor	1
D1	Steaming hot water (from boiler to tap) "110°C" red labelled flexible hose. M8 x 3/8" F	1
D2	3/8" fibre seal	1
E1	Domestic hot in (from mains feed) red banded flexible hose M10 x 1/2" BSPM (15mm)	1
F1	Domestic cold in (from mains feed) blue banded flexible hose M10 x 1/2" BSPM (15mm)	1
F2	Non return valve (factory fitted into flexible hose F1)	1
F3	15mm olive	0
F4	15mm nut	0
F5	15mm pipe	0
G1	15mm isolation valve	0
G2	15mm olive	0
G3	15mm nut	0
G4	15mm pipe	0
G5	15mm nut	2
G6	15mm olive	2
G7	1/2" x 1/2" x 3/4" isolating tee valve	1

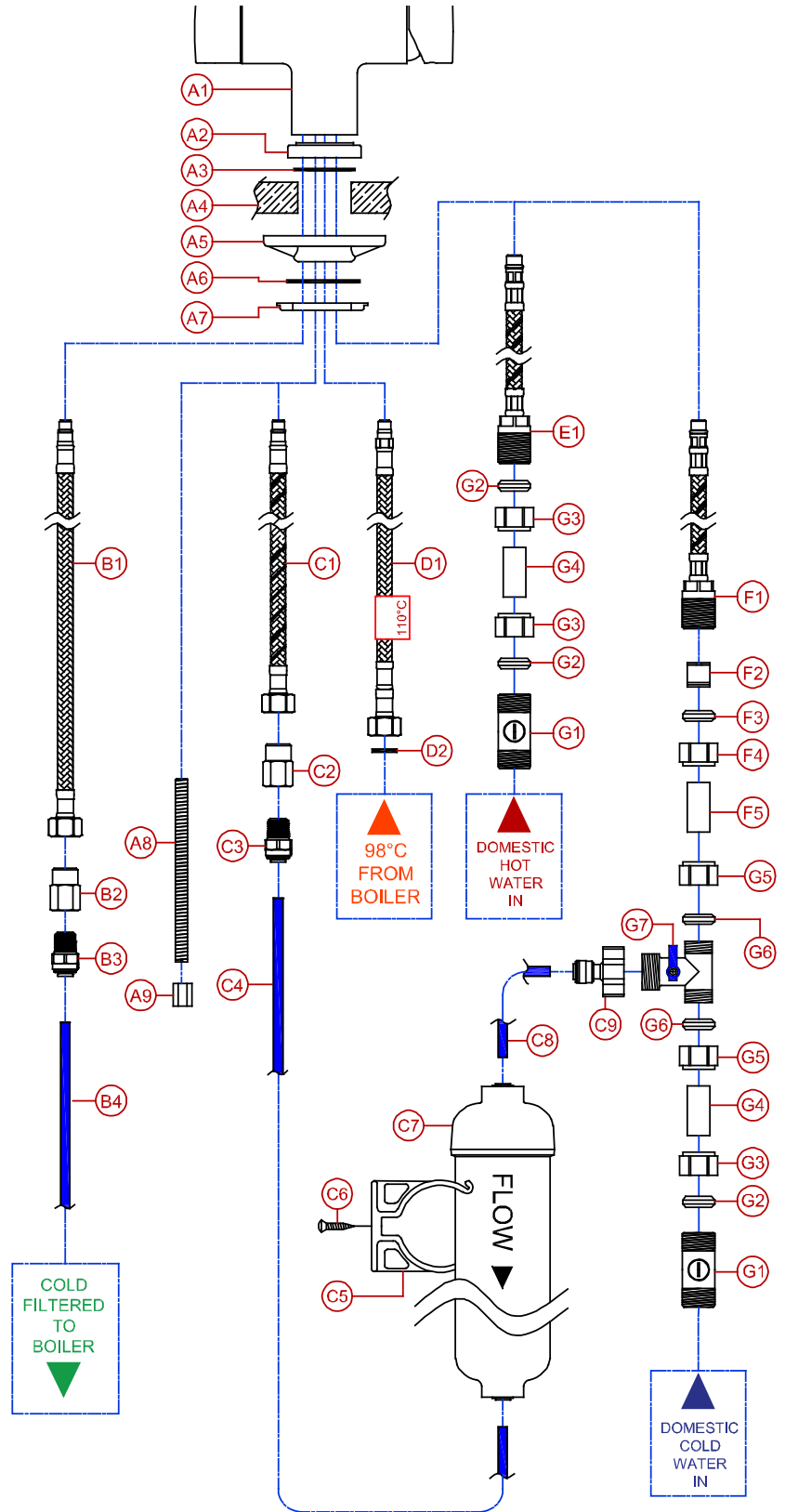

**\*\*Part supplied with boiler pack, cut to form required lengths to and from filter and boiler, for the boiler parts list and connections please refer to the instructions supplied with the boiler for more detail.**

## Tap & Filter installation

This diagram shows the view of the base of the tap (A1) with the 98°C water handle to the left of the body.

**⚠ YOU MUST CAREFULLY RESPECT THE INLETS AND OUTLETS AS SHOWN**

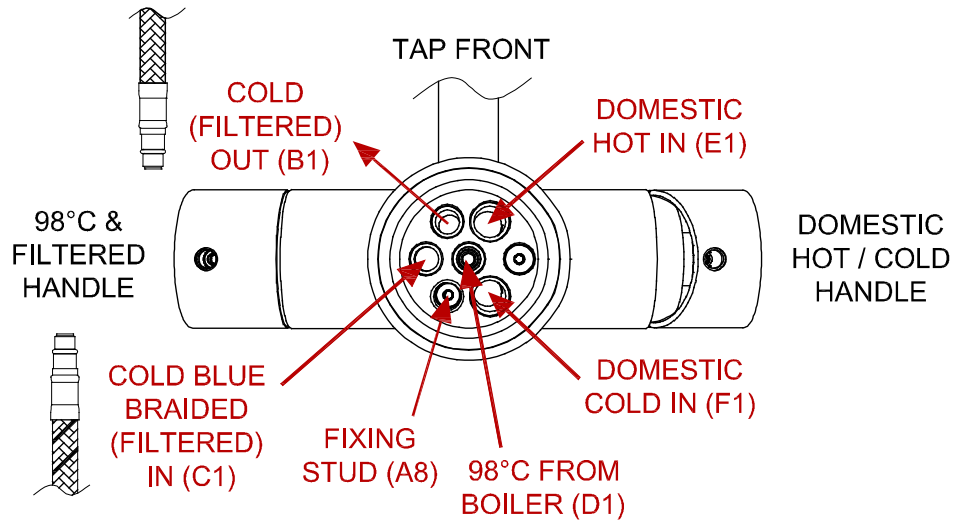

### Install the tap:

1. Screw the fixing stud (A8) into base of tap (A1) as shown on the diagram.
2. Place the base plinth (A2) and base plinth seal (A3) onto the base of the tap (A1).
3. Hand tighten the domestic hot in flexible hose (E1) as shown in the diagram.
4. Hand tighten the domestic cold in flexible hose (F1) as shown in the diagram.

5. **Hand tighten the filtered cold in flexible hose (C1) as shown in the diagram.**
6. **Hand tighten the filtered cold out flexible hose (B1) as shown in the diagram.**

**⚠ TAKE CARE NOT TO INVERT (C1) & (B1). DOING SO WILL RESULT IN NO FILTERED WATER**

7. Hand tighten the 110° rated steaming hot flexible hose (D1) into the centre inlet as shown on the diagram.
8. Place the tap (A1-A3) centrally and straight to the tap hole, passing the fixing stud (A8), flexi hoses (B1, C1, D1, E1 & F1) through the tap hole.
9. Pass the lower gasket (A6) then the metal horseshoe (A7) over the fixing stud (A8). Note: only if the tap is to be fitted to a stainless steel sink then the white triangular plate (A5) can be fitted where shown to improve the stability of the tap.
10. Using a 13mm box spanner or small adjustable spanner tighten fixing nut (A9) onto the fixing stud (A8).
11. Screw pushfit (B3) into brass adaptor (B2) and pushfit (C3) into brass adaptor (C2)

**⚠ We recommend using PTFE tape (do not use sealing compound) on the thread of the pushfit fittings to make a good seal without applying excessive force (which may damage the plastic pushfit if overtightened).**

12. Screw pushfit (B3) and adaptor (B2) into the filtered cold out flexible hose (B1).
13. Screw pushfit (C3) and adaptor (C2) into the filtered cold in flexible hose (C1).
14. Connect the domestic hot water flexible hose (E1) to the hot water isolation valve (G1) using a section of 15mm pipe (G4) and compression nuts (G3) and olives (G2).
15. Arrange and install the domestic cold in isolation valve (G1) and a stub of 15mm pipe (G4) using 15mm compression nut (G3) and olive (G2).
16. Fix the ½" x ½" x ¾" isolating tee valve (G7) to the cold water feed pipe (G4) using 15mm compression nut (G5) and olive (G6). Ensure to arrange the blue lever on the Tee so it is easily accessible for your customer.

**⚠ If your customer has a water softener installed you must attach the isolating Tee valve (G7) to an unsoftened cold water source, the cold water in flexible hose (F1) can however connect to either a softened or unsoftened water source.**

17. Connect the domestic cold in flexible hose (F1) to the ½" x ½" x ¾" isolating tee valve (G7) using 15mm compression nut (G5), olive (G6) and a section of 15mm pipe (F5).
18. Screw the ¾" BSP x ¼" pushfit (C9) onto the three-way valve (G7) ¾" male output.

## Install the Filter:

1. Find a suitable place to mount the filter cartridge (C7) under the sink, **it must be mounted vertically**, easily accessible (to be changed periodically), away from any heat source or electrical connections and close enough not to exceed the available length of the ¼" plastic pipe (B4,C4,C8) supplied to reach the between the tap, filter and boiler (place the boiler temporarily to help judge the required lengths of ¼" plastic pipe).
2. Using the self-tapping screw (C6) securely fix the filter bracket (C5) to the cabinet wall.
3. Write the installation date onto the filter label in permanent pen.
4. Clip the filter cartridge (C7) into the bracket (C5) as shown.  
You must respect the direction of flow as indicated on the filter cartridge (C7).
5. Measure and then cut required length of ¼" pipe (C4) to connect pushfit (C3) to the filter cartridge (C7) outlet, allow a small amount of extra length to make it easier to change the filter.
6. Firmly push connect the ¼" pipe (C4) between pushfit (C3) and filter cartridge outlet (C7).
7. Measure and then cut required length of ¼" pipe (C8) to connect pushfit (C9) to the filter cartridge (C7) inlet, allow a small amount of extra length to make it easier to change the filter.
8. Firmly push connect the ¼" pipe (C8) between pushfit (C9) and filter cartridge inlet (C7).
9. Firmly push connect the remaining ¼" pipe (B4) into pushfit (B3).

## After installation of the tap and filter is complete

1. Ensure that the isolating Tee valve (G7) is in the closed position as shown.
2. Close (turn off) both handles on the tap.
3. Reconnect the domestic hot and cold water supplies and open hot and cold isolating valves (G1). As the system starts to refill, check carefully all new water connection for leaks. After the product installation is complete we recommend you recheck for any slower leaks.

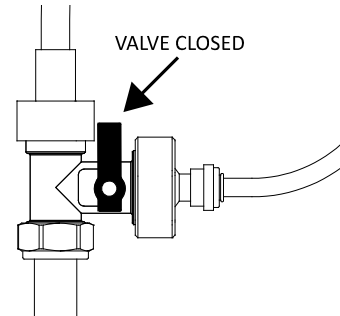

It is normal for new filter cartridges to lose a small amount of loose carbon when first used and will dissipate with flushing, whilst harmless to consume if the carbon particles are not flushed prior to connection to the boiler they may partly block the boiler and reduce the flow rate. **You must flush the filter for at least 2 litres with cold water or until the water become clear** (without black carbon particles).

4. Ensure that the isolating Tee valve (G7) is in the open position as shown.
5. Place the ¼" pipe (B4) from the tap into a bowl or bucket.
6. Turn on the 98°C forwards handle fully, keep the lever open until all air is expelled and cold (filtered) water exits the ¼" pipe (B4) into the bowl, flush a minimum of a further 2 litres of cold (filtered) water through the ¼" pipe (B4). You may notice a discolouration to the water at first, this is loose carbon particles from the filter it is normal, harmless and will pass with flushing. Continue to flush the filter until the water runs clear. Once complete turn off the 98°C handle.

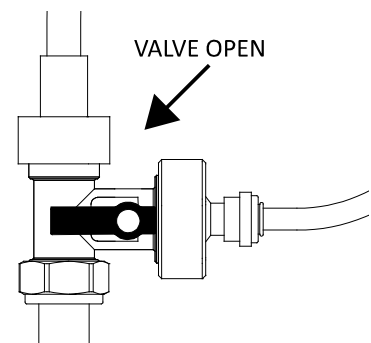

19. You can adjust the flow rate of the filtered water going to both the tap and boiler by adjusting the position of the blue lever on the isolating Tee valve (G7), you should aim for approximately 1-2 litres for both cold filtered and boiled filtered water.
20. **Please refer to 'PROBOIL.2X User & Installation Guide' for the next steps on how to install the boiler and connect the tap and filter.**

## Using the product

### Your tap can dispense 4 types of water:

- **Cold (filtered) water** – This is delivered when the left side handle is rotated backwards up to a maximum of apx. 45° (Fig 1).
- **Hot (boiled & filtered) water** Fully push the left side handle lever down (Fig 2.) and then simultaneously turn the handle forwards (Fig 3.), the further forwards the lever is turned the greater the flow up to a maximum of apx. 45°. It is normal for the hot water to take a moment to start and stop dispensing as the water empties from the product after use.
- **Hot & Cold (domestic) water** – Mixed water is delivered when the right-side handle is tilted right (Fig. 4). With the handle tilted Cold water is delivered when pushed backwards, and Hot is delivered when pulled forwards.

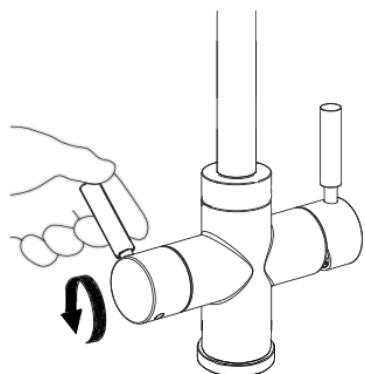

Fig 1.

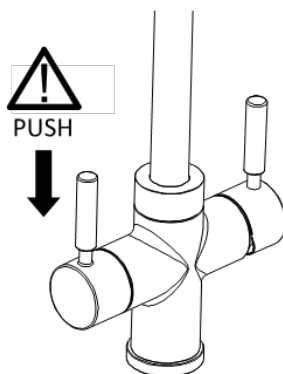

Fig 2.

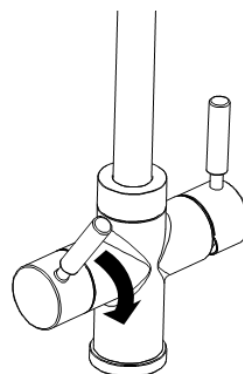

Fig 3.

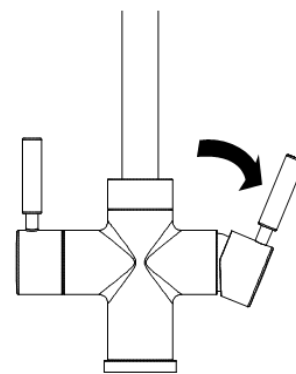

Fig 4.

Each time the product is used you should flush a small amount of boiled water through before use, typically this can be used to preheat your cup, if unused for extended periods then flush the product a longer time.

**⚠ WARNING: THIS APPLIANCE CAN BE USED BY CHILDREN AGED FROM 8 YEARS AND ABOVE AND PERSONS WITH REDUCED PHYSICAL, SENSORY OR MENTAL CAPABILITIES OR LACK OF EXPERIENCE AND KNOWLEDGE ONLY IF THEY HAVE BEEN GIVEN SUPERVISION OR INSTRUCTION CONCERNING USE OF THE APPLIANCE IN A SAFE WAY AND HAVE UNDERSTAND THE HAZARDS INVOLVED. CHILDREN SHALL NOT PLAY WITH THE APPLIANCE. CLEANING AND USER MAINTENANCE SHALL NOT BE MADE BY CHILDREN. ALL WIRING AND INSTALLATION MUST BE SUPERVISED BY A SUITABLY QUALIFIED PERSON.**

**⚠** Do not add to, exchange or modify any component of the boiler or mixer tap, only genuine parts must be used. The spout exit or any part of the system must not include any additional third party adaptors, components or connections that will add resistance or modify the system.

**⚠** The installation should be periodically checked for damage, if the property is left unattended for a prolonged period we recommend isolating water supplies and switching off the boiler at the mains socket, on reconnection flush thoroughly.

**Please leave these instructions for your customer.**