

Guarantee (UK only):

Your tap has the benefit of a comprehensive manufacturer's guarantee, details of which are shown on your Proof of Purchase Document. Any claim during the period of the guarantee must be accompanied by the Proof of Purchase. The product must be correctly installed and operated in accordance with the manufacturer's instructions and used for normal domestic purposes. This guarantee does not cover accidental damage, misuse or alterations which are likely to affect the product. The guarantee is invalid if the product is tampered with, or repaired by any unauthorised person. The guarantee in no way affects your statutory or legal rights.

Care Instructions for your Kitchen Sink Mixer:

To maintain the appearance of this tap, ensure that it is regularly cleaned only using a clean, soft damp cloth. A solution of warm water and a mild liquid detergent may be used where necessary, and then the fitting rinsed thoroughly and wiped dry. Any other cleaning action will invalidate your warranty. If the tap has a diffuser it can be unscrewed and cleaned periodically to maintain flow performance.

Abrasive cleaners, scouring cleaners and acidic cleaners **must not be used** under any circumstances. Avoid contact with all solvents (including chlorinated solvents, ketones or acetones as these may result in surface deterioration or etching). Also avoid contact with any harsh household chemicals such as oven cleaners, drain cleaners, rust removers, paint strippers and toilet bowl cleaners, bar keepers friend or Brasso.

Where the tap has a removable aerator on the spout exit it can be removed and cleaned periodically to maintain optimum flow performance.

Important Technical Data:

Minimum operating pressure: 0.3 bar
Maximum operating pressure: 5.5 bar*
Flow characteristics: Single flow

Maximum hot water temperature: 70°C*
Recommended hot water temperature: 46°C

*If these temperatures or pressures are exceeded, even for short periods, damage can result. In these instances a thermostatic mixing or pressure reducing valve should be installed.

This product is manufactured in accordance with recognised European standards. Please ensure that your Kitchen mixer is fitted in accordance with Local Water Byelaws. Where hot and cold water mix within the mixertap, then suitable non return (check) valves should be installed to the hot and cold supplies to prevent backflow.

Hot and cold supply pressures should be as closely balanced as possible for best results. Supply pipes should maintain the maximum diameter until immediately before the fitting. The differential between the hot and cold water supply temperatures should be sufficient to allow correct mixing function.

These installation guidelines have been prepared for your direction and you must exercise due care at all times. We do not accept responsibility for problems that may occur through improper installation. Whilst assembling the tap take care not to accidentally loosen any factory fixed assemblies.

This tap has been 100% assembly tested; therefore you may expect a small residual amount of water to remain in the tap when delivered. Any water marks can be removed using the above care advice.

Installation Preparation:

All parts should be removed from their packaging and inspected for completeness and transport damage prior to installation.

Before installing the new mixer **it is essential that you thoroughly flush through the supply pipes** in order to remove any remaining solder, swarf or impurities from your system. Failure to carry out this simple procedure could cause problems or damage to the workings of the mixertap and invalidate the warranty.

We recommend installing isolation valves and particle (mesh) filters to both the hot and cold feed pipes in an accessible position. This will help to prevent premature failure of the valves and ease any future maintenance.

Shut off the water heating system and ensure that the mains stopcock is closed. Ensure both the hot and cold water supplies are isolated before commencing installation.

This mixertap requires a $\varnothing 35$ mm tap hole, if replacing an existing tap, remove the tap & clean the end of the feed pipes using wire wool, the tap hole area should be free from dirt and sealant. You should ensure that the product will both fit into the depth of the mounting surface available and reach the required outlet positions before installation.

Loosely position the tap and tail pipes to check if any alteration to the existing pipework is required, if this is the case do this now.

Installation:

1. **IMPORTANT:** Note that the handle moves 45° left (hot) and 45° right (cold) of the centre (mixed water) position. Decide on the required alignment of the tap handle to the sink bowls and the relevant resting position of the spout (see fig 1 for a suggested alignment). Note also that the spout is designed to rotate 360°

Fig 1

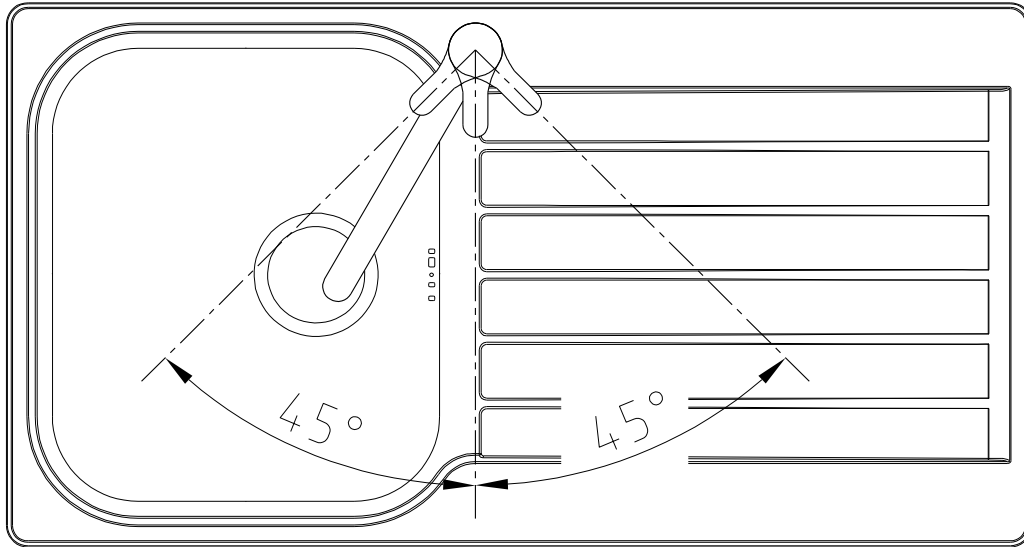

2. Screw the fixing stud (C) into the base of the tap (A).
3. Screw the hot and cold tail pipes (G) into the base of the tap body (A), note: the hot water should be connected to the left hand side of the tap when viewed from the front.
4. Place the upper seal (B) over tail pipes (G) and onto base of the tap body (A).
5. Place the mixertap (A) onto the sink or worktop and pass the tail pipes (G) and fixing stud (C) through the taphole. With the tap (A) in place check that the tail pipes (G) meet the hot and cold water feeds. If further adjustment to the plumbing is required do this now.
6. Pass the lower gasket (D) and then metal horseshoe (E) over the fixing stud (C) and around tail pipes (G).
7. Fasten the fixing nut (F) securely onto the fixing stud (C) fixing the tap into its correct location centred over the tap hole.
8. **IMPORTANT:** Once the tap is secured in position **do not** attempt to adjust the alignment of the tap (fig. 1) by gripping and twisting the tap body (A) or the handle; doing so could loosen the tap assembly or break the valve. Always loosen fixing nut (F) before re-aligning the tap.
9. Connect the hot & cold water tail pipes (G) to the water supplies using 1/2" BSP x 15mm compression olives and nuts (H & I) or similar.

After installation:

Once you have visually checked the installation of the new tap and all connections, ensure that all other fittings are closed except the new tap which should be left open.

Turn on your water heating system and ensure that your mains stopcock is open. Re-open both the hot and cold water supplies to this fitting.

Check the function of flow and function of hot, cold and mixed water.

Turn off the tap and check carefully for any leaks around all connections on the fitting and adjoining plumbing.

If possible return to the installation after a longer period to double check for slower leaks. If pressure testing equipment is available check the installation to the maximum recommended pressure.

Clean the tap to remove any marks created during installation as instructed then place a bag over the product to protect the tap until it is ready for use.

The installation should be periodically checked for damage, if the property is left unattended for a prolonged period we recommend isolating water supplies.

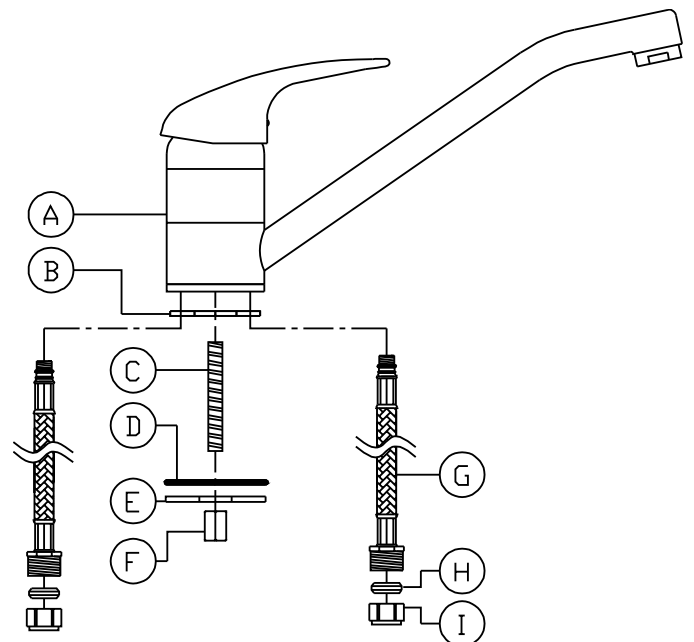

Key:	Description:	Qty.
A	Tap body	1
B	Upper seal	1
C	Fixing stud	1
D	Lower gasket	1
E	Metal horseshoe	1
F	Fixing nut	1
G	Hot and cold Flexible pipe	2
H	15mm compression olive	2
I	15mm compression nut	2