

TAP6000-2, TAP6002-2 & TAP6004-2

Arroscia 3 in 1 Hot Water Tap

LAMONA
Exclusive to Howdens Joinery Co.

02-20

Guarantee (UK only):

Your tap has the benefit of a comprehensive manufacturer's guarantee, details of which are shown on your Proof of Purchase Document. Any claim during the period of the guarantee must be accompanied by the Proof of Purchase. The product must be correctly installed and operated in accordance with the manufacturer's instructions and used for normal domestic purposes. This guarantee does not cover accidental damage, misuse or alterations which are likely to affect the product. The guarantee is invalid if the product is tampered with, or repaired by any unauthorized person. The guarantee in no way affects your statutory or legal rights.

Care Instructions for your Kitchen Sink Mixer:

To maintain the appearance of this tap, ensure that it is regularly cleaned only using a clean, soft damp cloth. A solution of warm water and a mild liquid detergent may be used where necessary, and then the fitting rinsed thoroughly and wiped dry. Any other cleaning action will invalidate your warranty.

Abrasive cleaners, scouring cleaners and acidic cleaners **must not be used** under any circumstances. Avoid contact with all solvents (including chlorinated solvents, ketones or acetones as these may result in surface deterioration or etching). Also avoid contact with any harsh household chemicals such as oven cleaners, drain cleaners, rust removers, paint strippers and toilet bowl cleaners, bar keepers friend or Brasso.

Where the tap has a removable aerator on the spout exit it can be removed and cleaned periodically to maintain optimum flow performance.

Important Technical Data:

Minimum operating pressure (hot): 0.75 bar	Minimum operating pressure (cold): 1.5 bar
Maximum operating pressure: 5.5 bar*	Maximum domestic hot water temperature: 70°C*
Flow characteristics: Domestic Hot & Cold share outer single flow spout. Boiled water: Through centre spout channel.	Recommended domestic hot water temperature: 46°C

*If these temperatures or pressures are exceeded, even for short periods, damage can result. In these instances a thermostatic mixing or pressure reducing valve should be installed.

This product is manufactured in accordance with recognised European standards. Please ensure that your kitchen mixer is fitted in accordance with Local Water Byelaws. **Where hot and cold water mix within the tap, then suitable non return (check) valves should be installed to both the hot and cold supplies to prevent backflow**, a preinstalled non return valve on the cold supply flexi hose (B6) is already supplied (see instructions key).

Hot and cold supply pressures should be as closely balanced as possible for best results. Supply pipes should maintain the maximum diameter until immediately before the fitting. The differential between the hot and cold water supply temperatures should be sufficient to allow correct mixing function.

These installation guidelines have been prepared for your direction and you must exercise due care at all times. We do not accept responsibility for problems that may occur through improper installation. Whilst assembling the tap take care not to accidentally loosen any factory fixed assemblies.

This tap has been 100% assembly tested; therefore you may expect a small residual amount of water to remain in the tap when delivered. Any water marks can be removed using the above care advice.

Installation Preparation

 **Before installing the new mixer it is essential that you thoroughly flush through the supply pipes in order to remove any remaining solder, swarf or impurities from your system. Failure to carry out this simple procedure could cause problems or damage to the workings of the mixertap or boiler.**

We recommend installing particle filters (not shown) and isolation valves (B5) to both the hot and cold feed pipes in an accessible position. This will help to prevent premature failure of the valves and ease any future maintenance.

Ensure you have suitable domestic hot and cold water pressure before installing this product (see technical data for more information).

All parts should be removed from their packaging and inspected for any transport damage and that all parts are present prior to installation.

Shut off your water heating system and ensure that your mains stopcock is closed. Open the lowest hot and cold taps in the house and allow the water to run until fully stopped.

If replacing an existing tap, remove the tap & clean the end of the feed pipes using wire wool, the tap hole area should be free from dirt and sealant. Loosely position the tap and tail pipes to check if any alteration to the existing pipework is required, if this is the case do this now.

Parts and Contents

Key	Description	Qty
A1	Mixer tap	1
A2	Base plinth	1
A3	Base plinth seal	1
A4	Sink or worktop (max. 50mm)	0
A5	White triangular plate (for use with steel sinks only)	1
A6	Lower gasket	1
A7	Metal horseshoe	1
A8	Fixing stud	1
A9	Fixing nut	1
B1	Domestic hot in (from mains feed) red banded flexible hose M10 x ½" BSPM (15mm)	1
B2	15mm olive	0
B3	15mm nut	0
B4	15mm pipe	0
B5	15mm isolation valve	0
B6	Domestic cold in (from mains feed) blue banded flexible hose M10 x ½" BSPM (15mm)	1
B7	Non return valve (factory fitted into flexible hose B6)	1
C1	Cold out (from tap to filter) flexible hose (M8 x 3/8" F), includes captive seal	1
C2	3/8" M x 1/4" F brass adaptor	1
C3	1/4" NPT M x 1/4" pushfit	1
C4	1/4" outside diameter plastic pipe	1**
C5	Filter bracket screw	1
C6	Filter bracket	1
C7	Filter cartridge	1
C8	1/4" outside diameter plastic pipe (cut from C4)	1**
D1	Steaming hot water (from boiler to tap) "110" red labelled flexible hose. M8 x 3/8" F	1
D2	3/8" fibre seal	1

****Part supplied with boiler pack, cut to form required lengths to and from filter and boiler, for the boiler parts list and connections please refer to the instructions supplied with the boiler for more detail.**

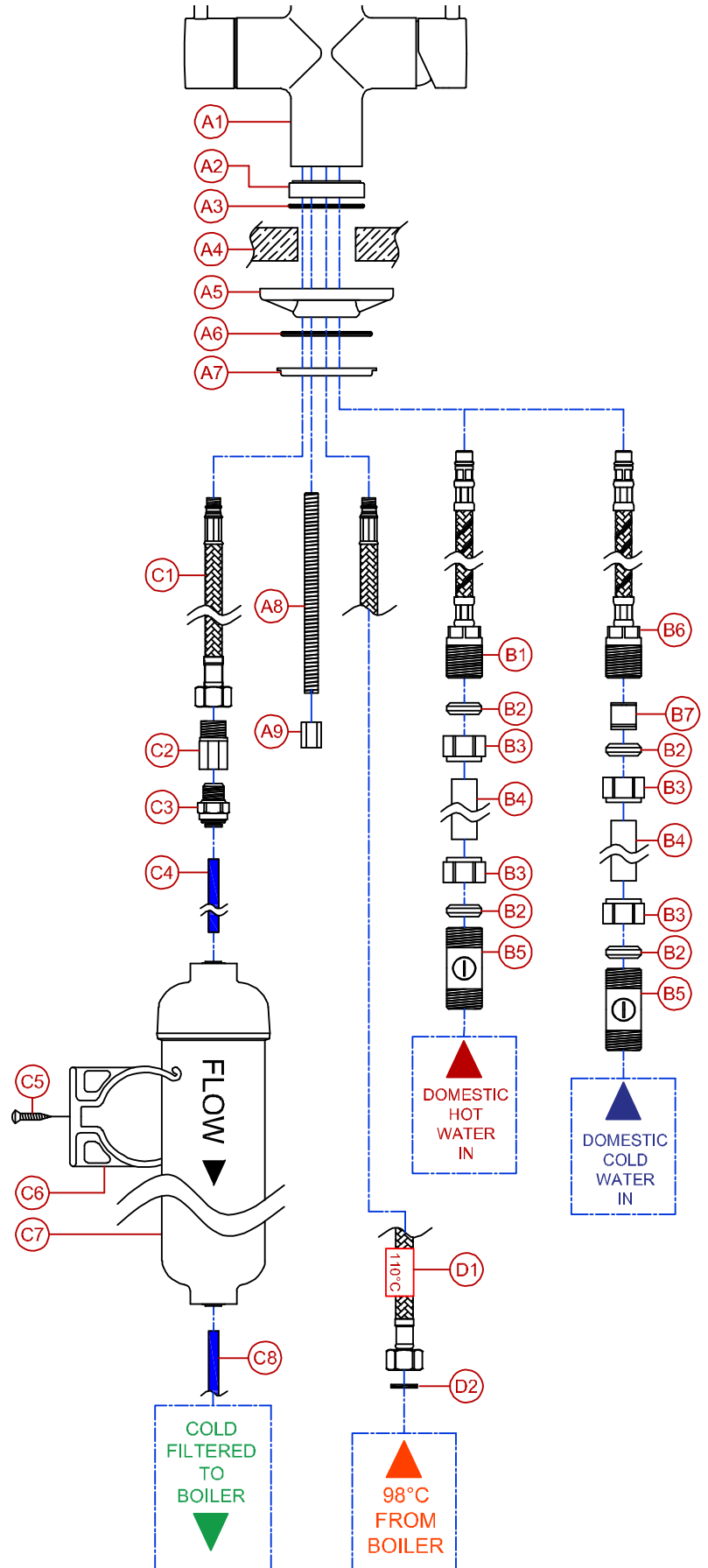

Install the tap:

This diagram shows the view of the base of the tap (A1) with the 98°C water handle to the left of the body.

! YOU MUST CAREFULLY RESPECT THE INLETS AND OUTLETS AS SHOWN

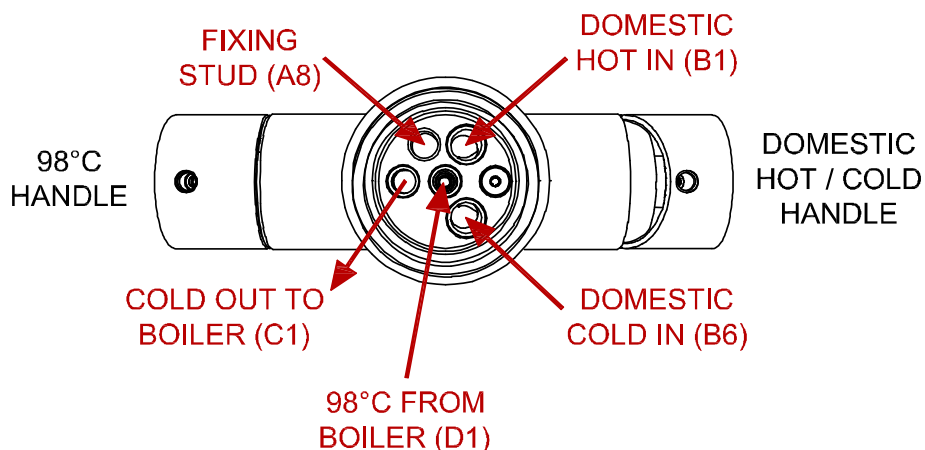

Install the tap:

1. Screw the fixing stud (A8) into base of tap (A1) as shown on the diagram.
2. Place the base plinth (A2) and base plinth seal (A3) onto the base of the tap (A1).
3. Hand tighten the domestic hot in flexible hose (B1) as shown in the diagram.
4. Hand tighten the domestic cold in flexible hose (B6) as shown in the diagram.
5. Hand tighten the cold out flexible hose (C1) as shown in the diagram.
6. Hand tighten the 110° rated steaming hot flexible hose (D1) into the centre inlet as shown on the diagram.
7. Place the tap (A1-A3) centrally and straight to the tap hole, passing the fixing stud (A8), flexi hoses (B1, B6, C1, & D1) through the tap hole.
8. Pass the lower gasket (A6) then the metal horseshoe (A7) over the fixing stud (A8). Note: only if the tap is to be fitted to a stainless steel sink then the white triangular plate (A5) can be fitted where shown to improve the stability of the tap.
9. Using a 13mm box spanner or small adjustable spanner tighten fixing nut (A9) onto the fixing stud (A8).
10. Screw pushfit (C3) into brass adaptor (C2).

! We recommend using PTFE tape (do not use sealing compound) on the thread of the pushfit fittings to make a good seal without applying excessive force (which may damage the plastic pushfit if overtightened).

11. Screw pushfit (C3) and adaptor (C2) into the cold out flexible hose (B1).
12. Connect the domestic hot water flexible hose (B1) to the hot water isolation valve (B5) using a section of 15mm pipe (B4) and compression nut (B3) and olive (B2).
13. Connect the domestic cold water flexible hose (B6) to the cold water isolation valve (B5) using a section of 15mm pipe (B4) and compression nut (B3) and olive (B2).

! If your customer has a water softener installed you must attach cold water flexible hose (B6) to an unsoftened cold water source.

Install the Filter:

1. Find a suitable place to mount the filter cartridge (C7) under the sink, **it must be mounted vertically**, easily accessible (to be changed periodically), away from any heat source or electrical connections and close enough not to exceed the available length of the ¼" plastic pipe (C4) supplied to reach the between the tap, filter and boiler (place the boiler temporarily to help judge the required lengths of ¼" plastic pipe).
2. Using the self-tapping screw (C5) securely fix the filter bracket (C6) to the cabinet wall.
3. Write the installation date onto the filter label in permanent pen.
4. Clip the filter cartridge (C7) into the bracket (C6) as shown.
You must respect the direction of flow as indicated on the filter cartridge (C7).
5. Measure and then cut required length of ¼" pipe (C4) to connect pushfit (C3) to the filter cartridge (C7) inlet, allow a small amount of extra length to make it easier to change the filter.
6. Firmly push connect the ¼" pipe (C4) between pushfit (C3) and filter cartridge inlet (C7).
7. Firmly push connect the remaining ¼" pipe (C8) into the filter cartridge outlet (C7).

After installation:

1. Reconnect the domestic hot and cold water supplies and open hot and cold isolation valves (B5). As the system starts to refill, check carefully all new water connections for leaks. After the product installation is complete we recommend you recheck for any slower leaks.
2.  It is normal for new filter cartridges to lose a small amount of loose carbon when first used and will dissipate with flushing, whilst harmless to consume if the carbon particles are not flushed prior to connection to the boiler they may partly block the boiler and reduce the flow rate. You must flush the filter for at least 2 litres with cold water or until the water become clear (without black carbon particles).
3. Place the ¼" pipe (C4) from the filter cartridge (C5) outlet into a bowl or bucket.
4. Turn on the 98°C forwards handle fully, keep the lever open until all air is expelled and cold (filtered) water exits the ¼" pipe (C4) into the bowl, flush a minimum of a further 2 litres of cold (filtered) water through the ¼" pipe (C4). You may notice a discolouration to the water at first, this is loose carbon particles from the filter it is normal, harmless and will pass with flushing. Continue to flush the filter until the water runs clear. Once complete turn off the 98°C handle.
5. **Please refer to 'PROBOIL.2X User & Installation Guide' for the next steps on how to install the boiler and connect the tap and filter.**

Using the product

Your tap can dispense 3 types of water:

- **Hot (boiled & filtered) water** Fully push the left side handle lever down (Fig. 1) and then simultaneously turn the handle forwards (Fig. 2), the further forwards the lever is turned the greater the flow. It is normal for the hot water to take a moment to start and stop dispensing as the water empties from the product after use.
- **Hot & Cold (domestic) water** - This is delivered when the right-side handle is tilted right (Fig. 3) to increase flow. Cold is a near vertical position becoming warmer as the handle is rotated forwards (Fig. 4).

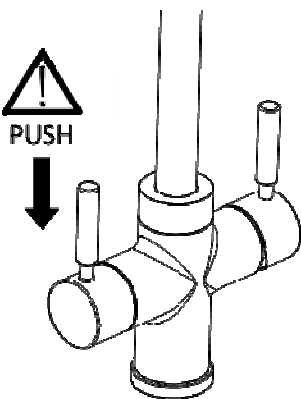

Fig 1.

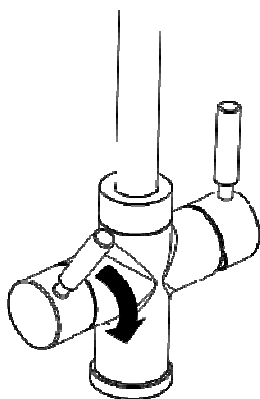

Fig 2.

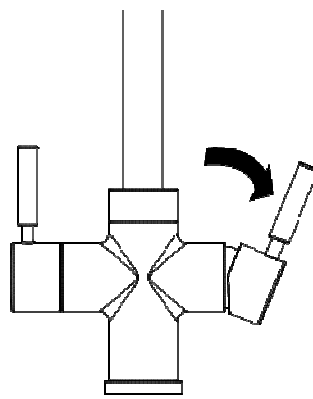

Fig 3.

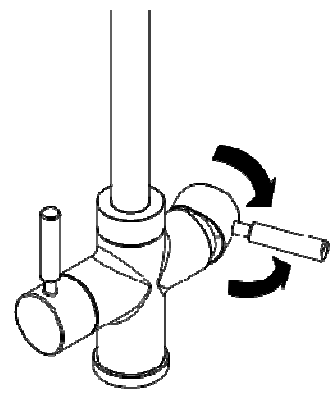

Fig 4.

Please leave these instructions for your customer.