

MARATHON 55 & 90

**FOR SLIDING
DOORS TO 55KG
AND 90KG**

For heavily used timber or metal doors, offering smooth and reliable action due to its precision engineering, solid alloy runner bar and one piece ball cage design.

KITS

Single door kits for max. door weights of 55kg and 90kg contain: top assembly (track, hanger plates, ball cage and runner bar); 2 nylon top plates (with integral buffer); wall mounted stops; nylon floor guide (guide channel to be mortised into door bottom rail).

OPTIONAL EXTRAS

Optional extras include: soffit brackets (5 off) no. 3/40; self-closing system pulley assembly SCK1 (advise door weight); biparting unit (2 doors each max 900mm) no. 23; anti-draught doorseal no. DSI; pelmet no. 40P and pelmet end caps (2 off) no. EC40P; flushpull no. 400; flushbolt no. 333; lock no.s 294, 295; door edge sponge strip no. 537 (see pp 52-57 for full product description). Bulk component packs are also available.

INSTALLATION NOTES

(also see drawing)

For internal fitting, or external with adequate protection for gear, can be face or soffit fixed. Bi-parting gear can be fitted to operate both doors simultaneously, and a self-closing pulley system is also available.

For door opening widths	Junior kit 55kg	Senior kit 90kg
400-750mm	J2	
750-900mm	J3	S3
900-1050mm	J4	S4
1050-1200mm	J5	S5
1200-1500mm	J6	S6
Max leaf size	3000 x 1500 x 50mm	

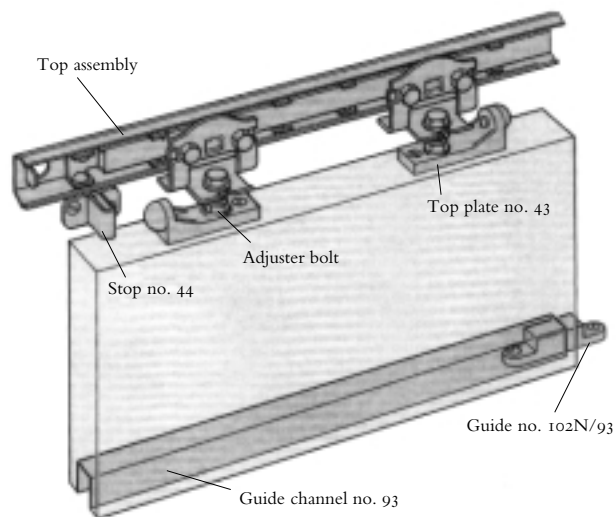

(See Component/Accessory pp 52-56 for product descriptions)

FACE FIXED

SOFFIT FIXED

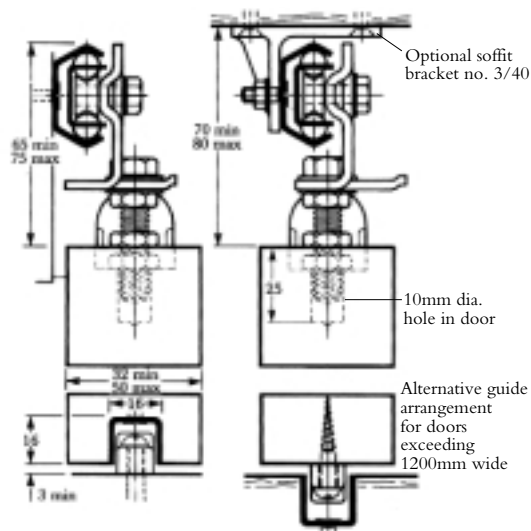

All dimensions in mm

HENDERSON MARATHON

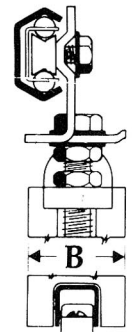
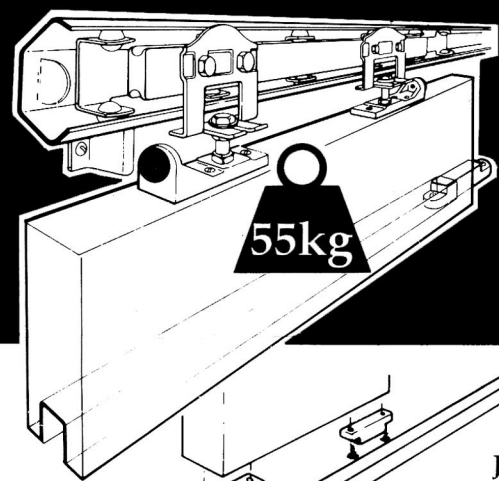

- J2 A = 400 - 750mm 55kg
- J3 A = 750 - 900mm 55kg
- J4 A = 900 - 1050mm 55kg
- J5 A = 1050 - 1200mm 55kg
- J6 A = 1200 - 1500mm 55kg

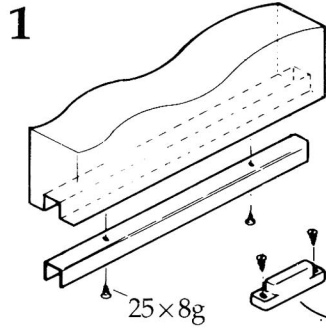
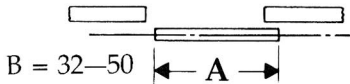

- J2
- J3
- J4
- J5

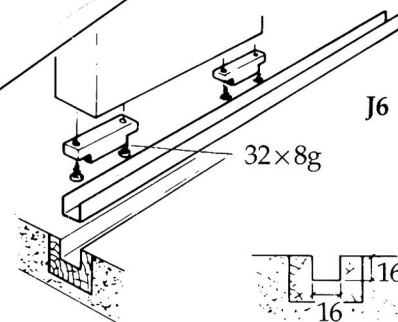

2

	mm	
	A	E
J2	400 - 750	267
J3	750 - 900	368
J4	900 - 1050	445
J5	1050 - 1200	546
J6	1200 - 1500	724

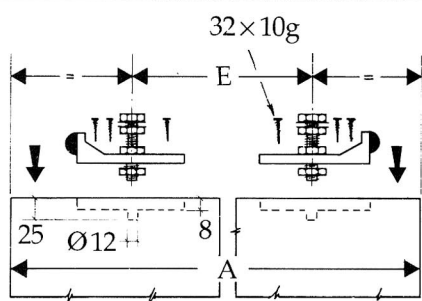

3

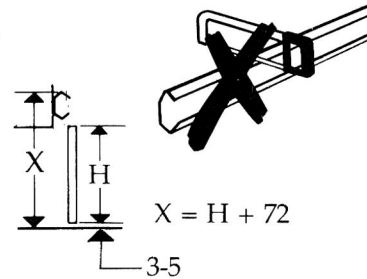
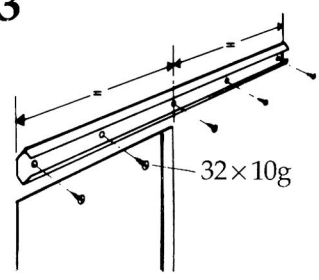

4

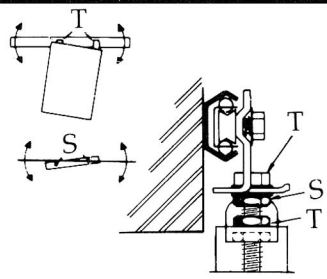
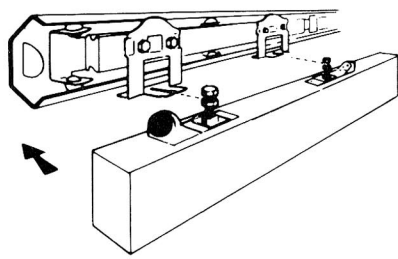

5

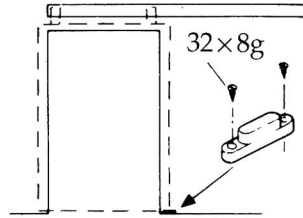

6

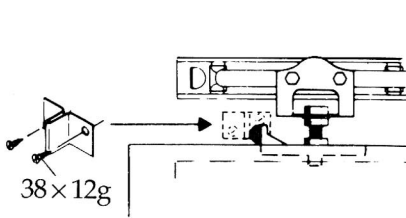

LUBRICATION INSTRUCTION

USING THE SACHET OF LUBRICANT SUPPLIED, APPLY LUBRICANT TO MARATHON ASSEMBLY BETWEEN TRACK AND BALLS.

RE-LUBRICATION - THE TRACK SHOULD BE RE-LUBRICATED AT REGULAR INTERVALS DEPENDING ON USE.

LUBRICANT INFORMATION

LUBRICANT - ANTI-SEIZE COMPOUND (POLYBUTYLSEPISE)
 CHEMICAL FAMILY - MINERAL OIL BASE
 HEALTH EFFECTS - EYES: IRRITATION CAN OCCUR.
 SKIN: IRRITATION CAN OCCUR.
 INGESTION: PRODUCES GASTRO-INTESTINAL DISTURBANCES.

FIRST AID - EYES: WASH WITH WATER AND CONSULT MEDICAL PRACTITIONER.
 SKIN: WASH WITH WARM WATER + SOAP.
 INGESTION: CALL MEDICAL PRACTITIONER IMMEDIATELY.
 INHALATION: BRING SUBJECT INTO FRESH AIR (CONSULT A MEDICAL PRACTITIONER)